



Military Reference Book



Air-cooled DC Generators

Water-cooled DC Generators

Water-cooled AC Generators 50 / 60 Hz

Water-cooled AC Generators 400 Hz

Combined Generator & Aircons / CAPS

PMGi Generator Technology

Environmental Control Units (ECUs)





1. Air-cooled DC Generators

Panda AGT 2500L	3
Panda AGT 3500L	4



2. Water-cooled DC Generators

Panda AGT 4000 PVMV-N	5
Panda AGT 4000/24V PVMV-N	6
Panda AGT 5000 PE-150N	7
Panda AGT 5000 PVM / 24(28)V DC	8
Panda AGT 5000 PE-150NA	9
Panda AGT 6000/24V PVMV-N	10
Panda AGT 10000 PVM-NE	11



3. Water-cooled AC Generators 50 / 60 Hz

Panda PU-2060N	12
Panda 8000 PSC	13
Panda 8000 PSC-H	14
Panda 8000 PSC	15
Panda 8000 PSC	16
Panda SST 10 Tunnel	17
Panda 12.000 PSC	18
Panda 12000 PSC	19
Panda 15/10	20
Panda 15 PSC	21
Panda 15 PSC	22
Panda 18 PVM	23
Panda 18 PSC	24
Panda SST 18	25
Panda 24 PSC	26
Panda 30 PSC	27
Panda 30 PVMV-N	28
Panda 30 PVMV-N	29
Panda 40 Lom PSC	30
Panda 47 Lom PSC	31
Panda 65 PSC	32



4. Water-cooled AC Generators 400 Hz

Panda AGT 12000 PSC	33
Panda AGT 6000 PSC	34
Panda AGT 10000	35



5. Combined Generator / Aircons (Combi) / Complete Systems

Panda 10 SST Combo	36
Panda 12 SST Combo	37
Panda 30 CAPS	38
Panda 60 CAPS	39



6. PMGi Generator Technology

Panda SST 25	40
--------------	----



7. Enviromental Control Units (ECUs)

Panda 6000 ECU	41
RTU-2 ECU	42

Disclaimer: All technical data and specifications including dimensions, performance data, weight and material specifications are only valid when they are explicitly expressed in writing. All data should be considered only for approximation purposes because the data from these sources is gathered from current and previous models. As a result of continual product improvement and modification, the validity of technical data from these sources cannot be guaranteed. It is the responsibility of the customer to ensure in all cases when ordering that technical data is valid and that the specifications meet his/her requirements.

1) 0,35l/kWh electrical power, randomized values between 30% and 80% of the power rating.

PANDA AGT 2500L



Generator	Panda AGT 2500L Air-cooled DC Generator
Constant Output	2,1 kW at sea level / +45°C
Output Voltage	24(28)V DC
Output Current	79A
Start System	24V Electrical
Engine Manufacturer	Yanmar
Engine Type	L48AE-DE
Engine Cylinders	1
Engine Operating Temp. Range	-20°C up to +55°C (other temperature ranges on request)
Fuel Types	F 34, F 54 „Standard automotive diesel fuel, kerosene, JP 8, JP 5, JET A
Approx. Fuel Consumption ¹⁾	0.9 l/h
Fuel Supply	Integrated 5l fuel tank + option for external
Frame / Mounting	Lightweight open frame for installing in well ventilated areas
Cooling System	Air cooling
Instrumentation & Electrical	Instrument and electrical connections on APU Frame
Approx APU weight (dry)	102 kg

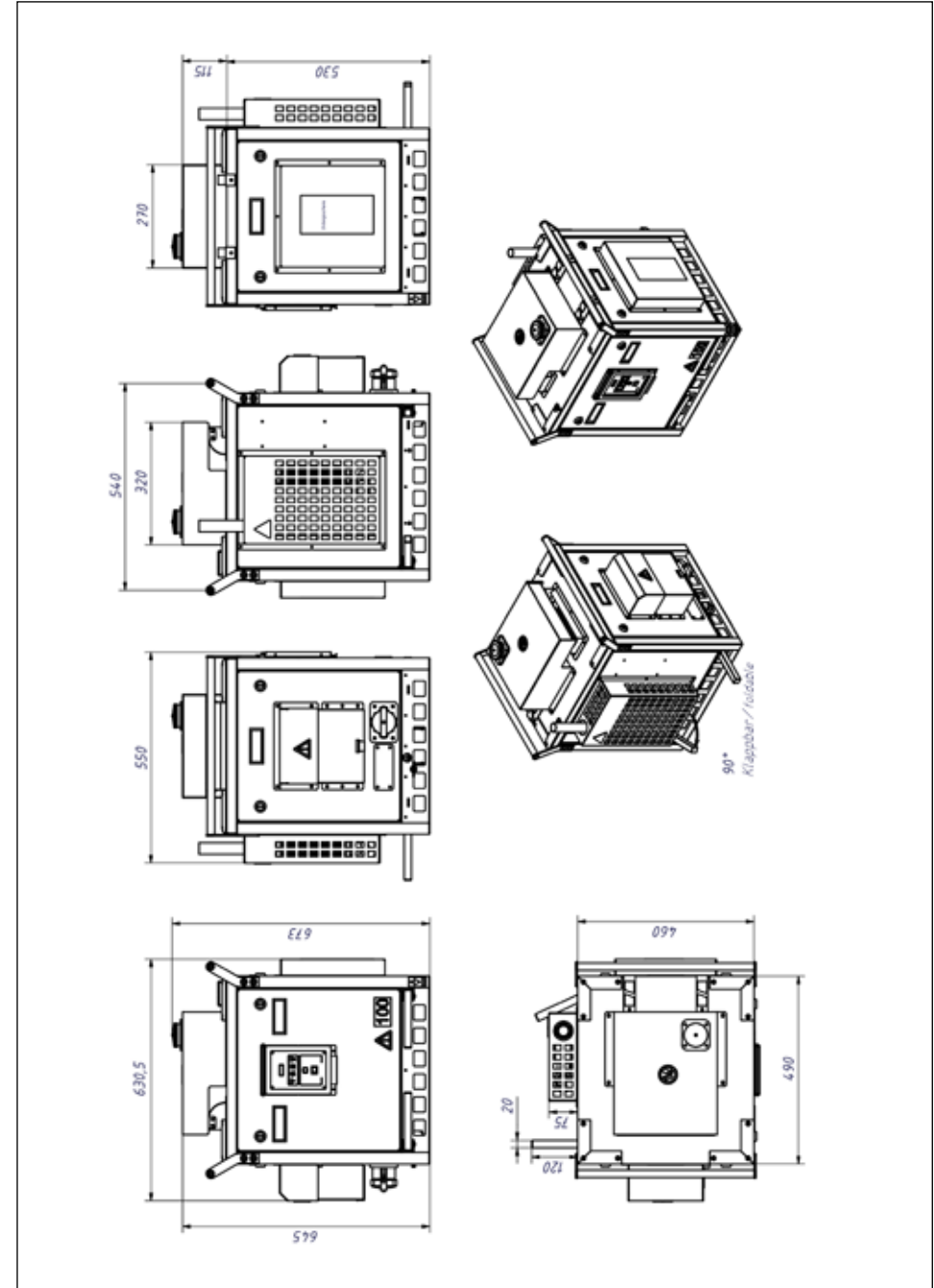

PANDA AGT 3500L



Generator	Panda AGT 3500L Air-cooled DC Generator with frame-mounted battery bank and fuel tank
Constant Output	3,2 kW at sea level / +50°C
Output Voltage	24(28)V DC
Output Current	90A
Start System	24V Electrical
Engine Manufacturer	Yanmar
Engine Type	L70AE-DE
Engine Cylinders	1
Engine Operating Temp. Range	-20°C up to +50°C (other temperature ranges on request)
Fuel Types	F 34, F 54 „Standard automotive diesel fuel, kerosene, JP 8, JP 5, JET A
Approx. Fuel Consumption ¹⁾	1.3 l/h
Fuel Supply	Integrated 5l fuel tank + option for external
Frame / Mounting	Lightweight open frame for installing in well ventilated areas
Cooling System	Air cooling
Instrumentation & Electrical	Instruments on APU Frame
Approx APU weight (dry)	128 kg

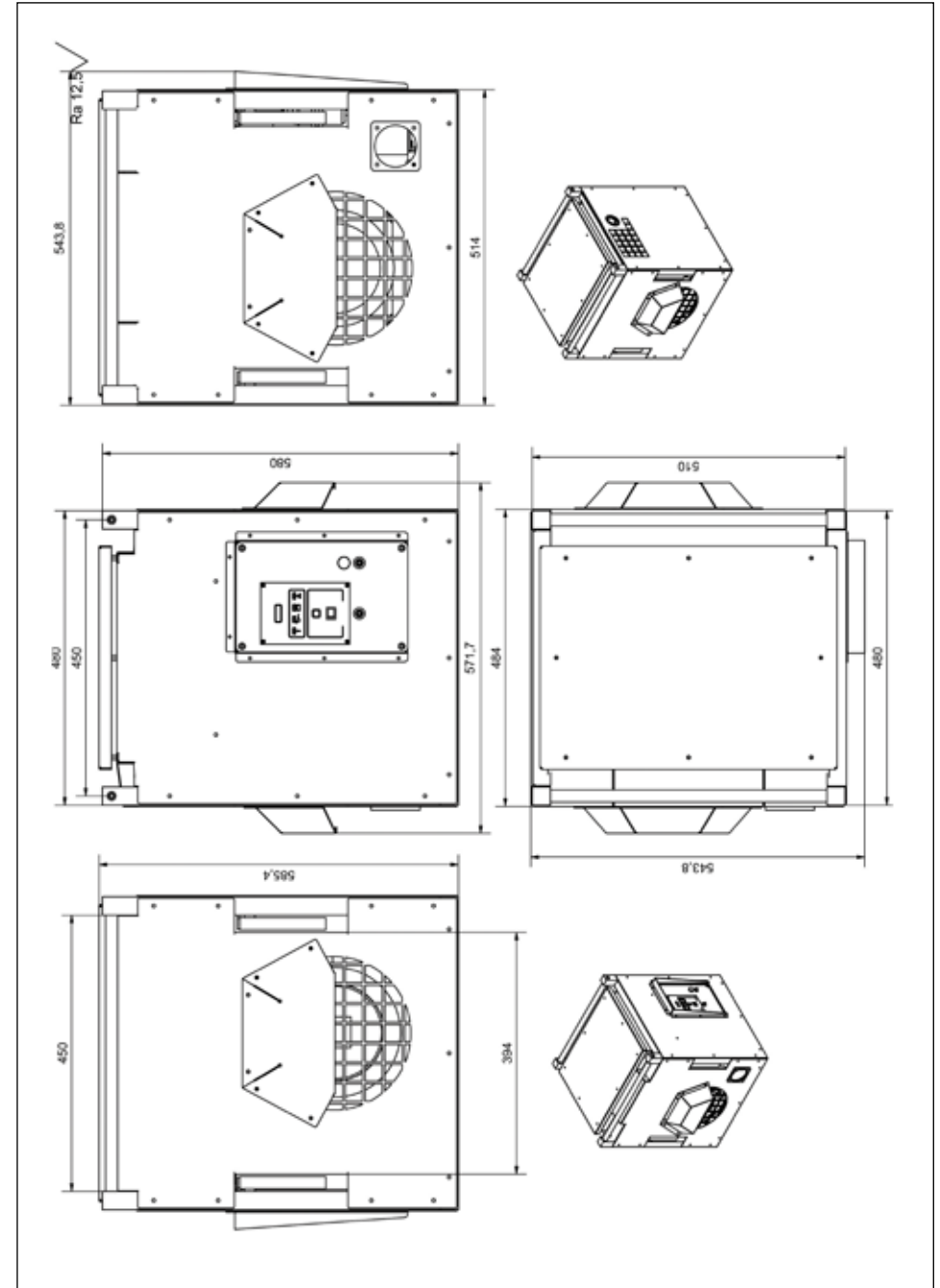

PANDA AGT 4000 PVMV-N

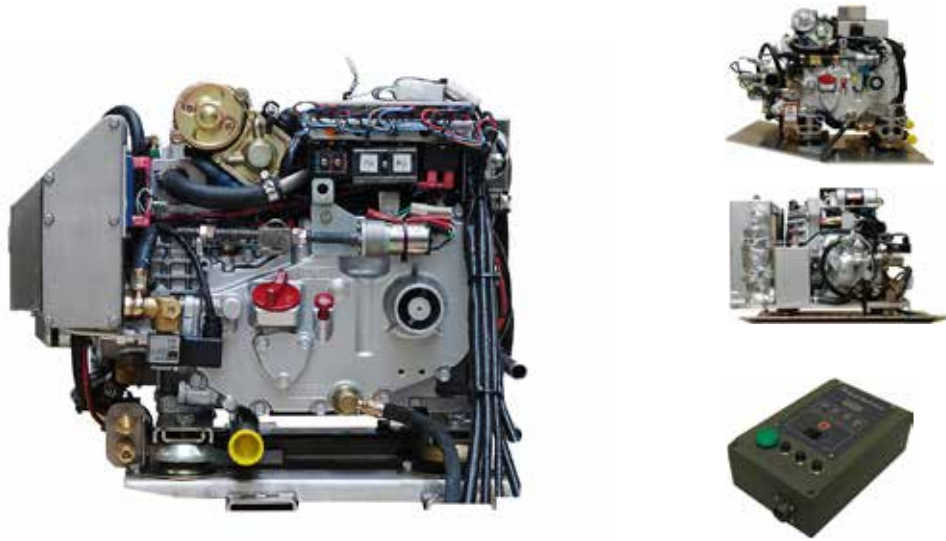

Generator	Panda AGT 4000 PVMV-N
	Water-cooled DC Generator (Suitable for installing inside tracked vehicle fender)
Constant Output	3,8 kW at sea level / +50°C
Output Voltage	24(28)V DC
Output Current	135A
Start System	24V Electrical
Engine Manufacturer	Kubota
Engine Type	EA 300
Engine Cylinders	1
Engine Operating Temp. Range	-20°C up to +50°C (other temperature ranges on request)
Fuel Types	F 34, F 54 ,Standard automotive diesel fuel, kerosene, JP 8, JP 5, JET A
Approx. Fuel Consumption ¹⁾	0.4 - 1.5 l/h
Fuel Supply	Connections for external or vehicle fuel tank
Frame / Mounting	For mounting within vehicle compartment or fender
Cooling System	Uses external radiator for cooling.
Instrumentation & Electrical	Externally Mounted Panel
Approx APU weight (dry)	90 kg without radiator

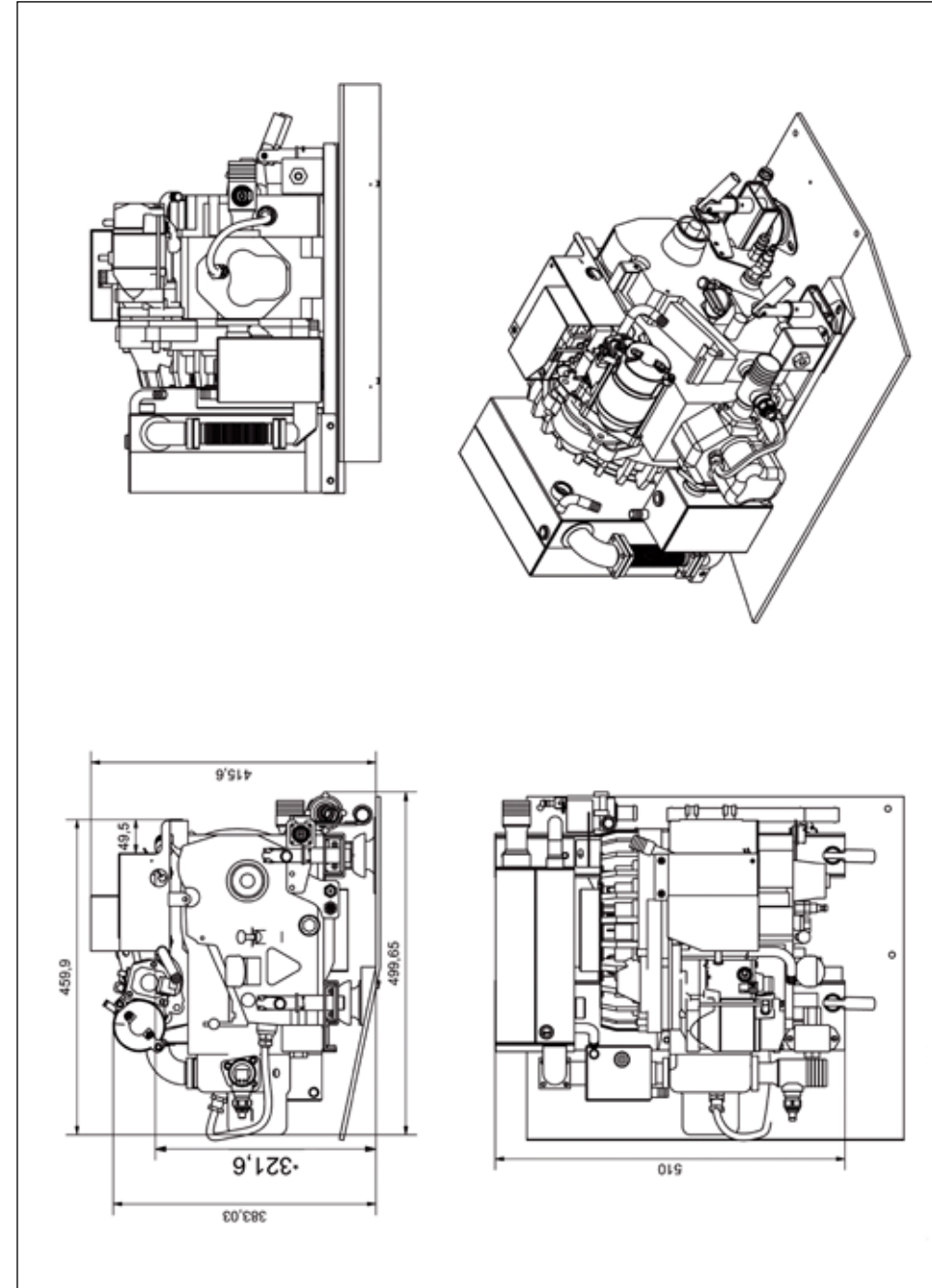

PANDA AGT 4000/24V PVMV-N



Generator	Panda AGT 4000/24V PVMV-N Water-cooled DC Generator
Constant Output	3,8 kW at sea level / +50°C
Output Voltage	24(28)V DC
Output Current	135A
Start System	24V Electrical
Engine Manufacturer	Kubota
Engine Type	EA 300
Engine Cylinders	1
Engine Operating Temp. Range	-20°C up to +50°C (other temperature ranges on request)
Fuel Types	F 34, F 54 „Standard automotive diesel fuel, kerosene, JP 8, JP 5, JET A
Approx. Fuel Consumption ¹⁾	0.4 - 1.5 l/h
Fuel Supply	Connections for external or vehicle fuel tank
Frame / Mounting	Generator mounted inside sound insulated capsule
Cooling System	Uses external radiator for cooling.
Instrumentation & Electrical	Externally Mounted Panel
Approx APU weight (dry)	142 kg without radiator

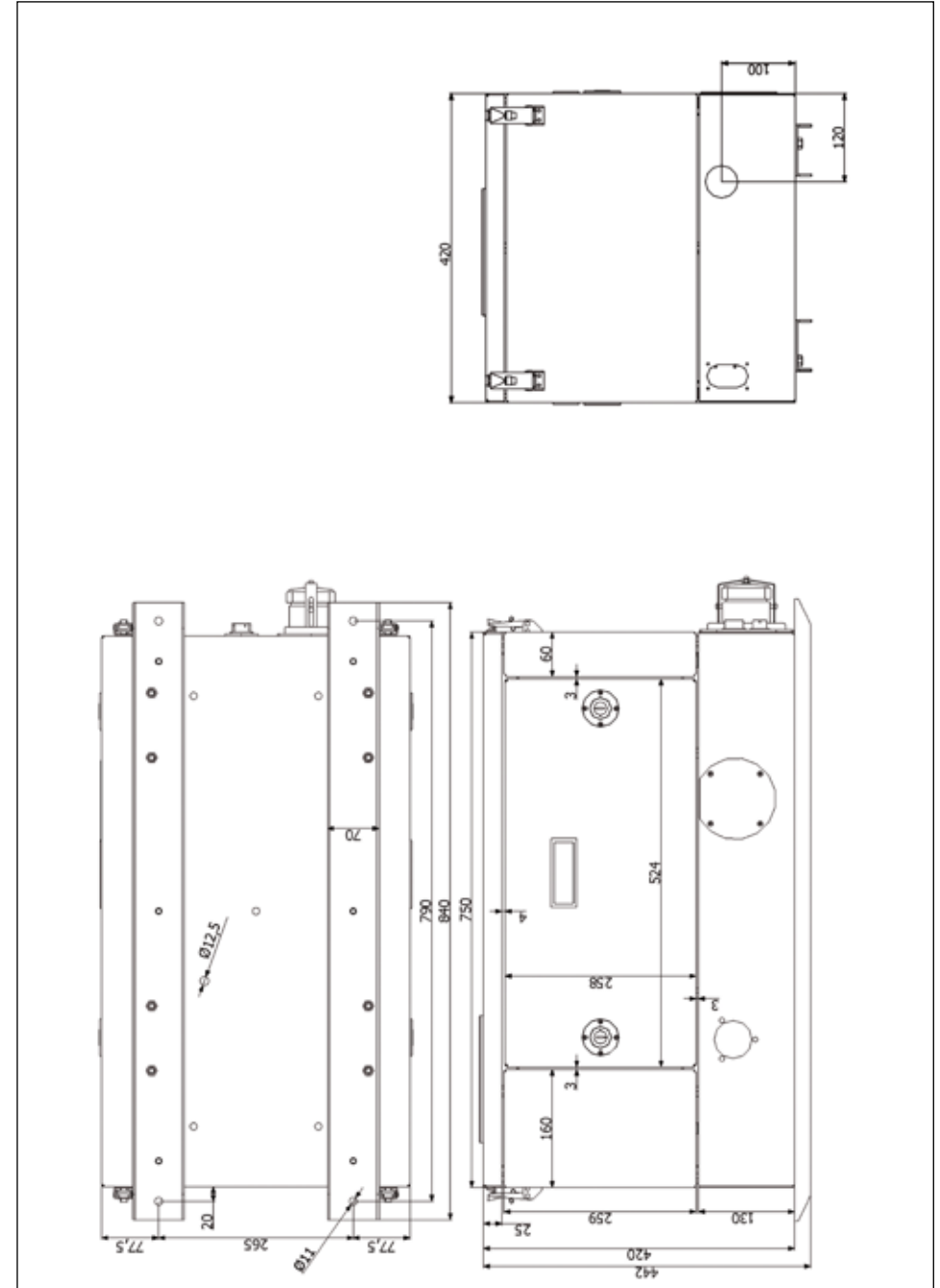

PANDA AGT 5000 PE-150N



Generator	Panda AGT 5000 PE-150N Water-cooled DC Generator (Suitable for mounting on M577 command post)
Constant Output	5 kW at 3000m / +50°
Output Voltage	24(28)V DC
Output Current	180A
Start System	24V Electrical
Engine Manufacturer	Kubota
Engine Type	D722
Engine Cylinders	3
Engine Operating Temp. Range	-32°C up to +50°C (other temperature ranges on request)
Fuel Types	F 34, F 54 „Standard automotive diesel fuel, kerosene, JP 8, JP 5, JET A
Approx. Fuel Consumption ¹⁾	0.6 - 1.8 l/h
Fuel Supply	Connections for external or vehicle fuel tank
Frame / Mounting	Generator mounted inside sound insulated capsule
Cooling System	integrated radiator and fans for cooling
Instrumentation & Electrical	Panel mounted in APU + external slave panel
Approx APU weight (dry)	240 kg

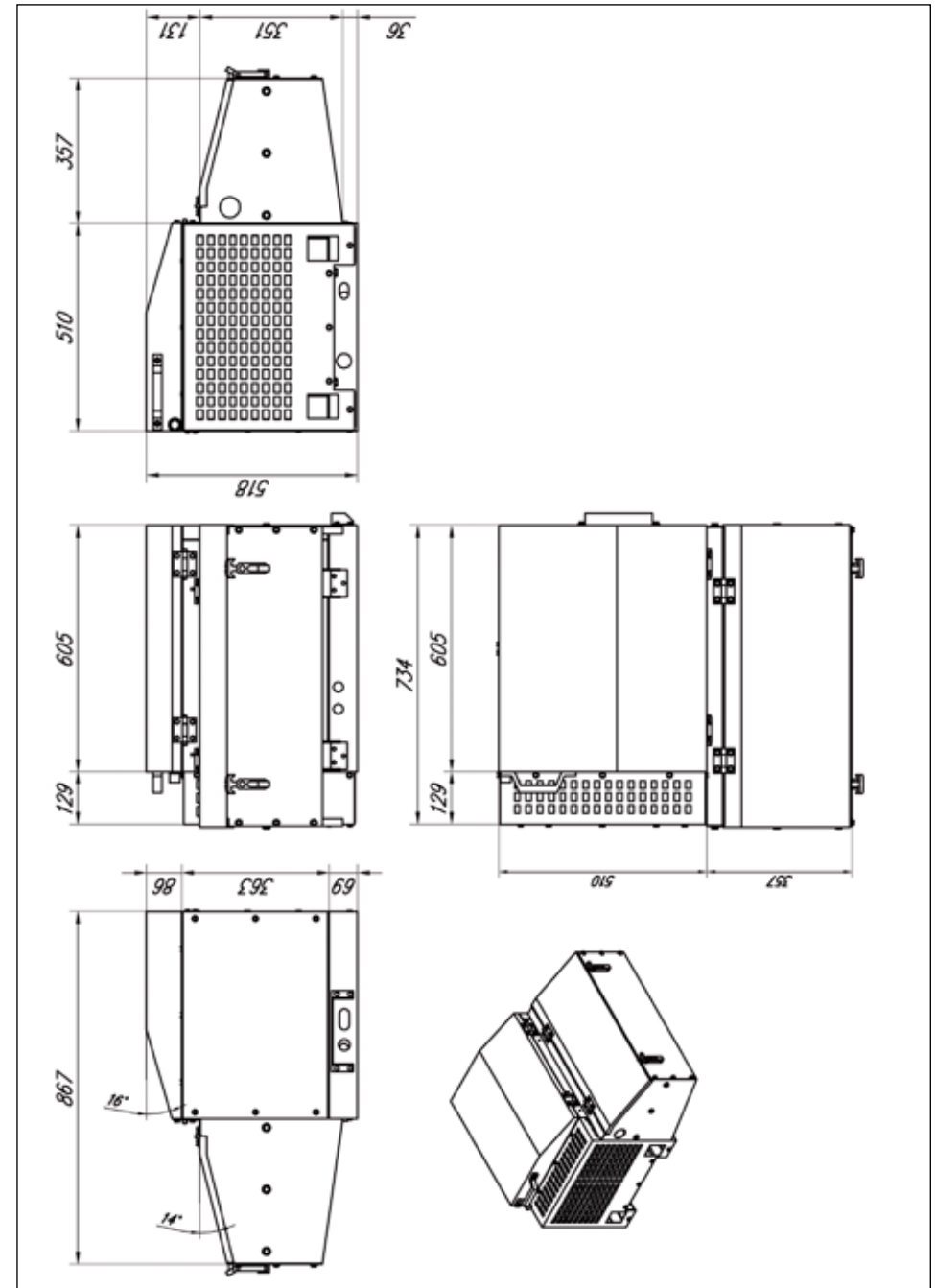

PANDA AGT 5000 PVM / 24(28)V DC



Generator	Panda AGT 5000 PVM / 24(28)V DC Water-cooled DC Generator
Constant Output	5 kW at 3000m / +50°C
Output Voltage	24(28)V DC
Output Current	180A
Start System	24V Electrical
Engine Manufacturer	Kubota
Engine Type	D722
Engine Cylinders	3
Engine Operating Temp. Range	-32°C up to +50°C (other temperature ranges on request)
Fuel Types	F 34, F54, Standard automotive diesel fuel, kerosene, JP 8, JP 5, JET A
Approx. Fuel Consumption ¹⁾	0.6 - 1.8 l/h
Fuel Supply	Connections for external or vehicle fuel tank
Frame / Mounting	Generator mounted inside sound insulated capsule
Cooling System	Integrated radiator and fans mounted for cooling
Instrumentation & Electrical	Remote control panel
Approx APU weight (dry)	240 kg

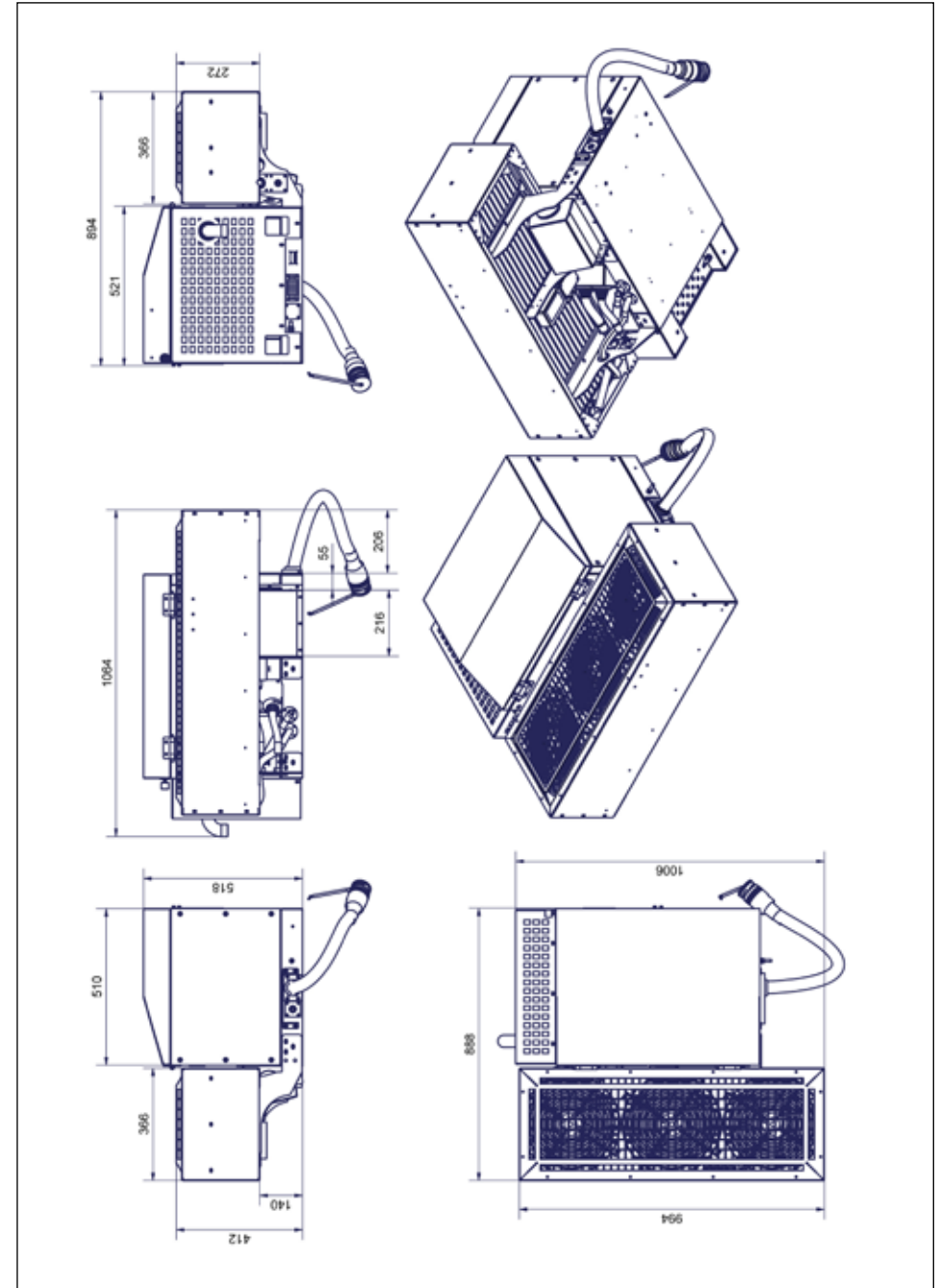

PANDA AGT 5000 PE-150NA



Generator	Panda AGT 5000 PE-150NA
	Water-cooled DC Generator with external radiator cooler for mounting on M113
Constant Output	5 kW at 3000m / +50°
Output Voltage	24(28)V DC
Output Current	180A
Start System	24V Electrical
Engine Manufacturer	Kubota
Engine Type	D722
Engine Cylinders	3
Engine Operating Temp. Range	-32°C up to +50°C (other temperature ranges on request)
Fuel Types	F 34, F 54 ,Standard automotive diesel fuel, kerosene, JP 8, JP 5, JET A
Approx. Fuel Consumption ¹⁾	0.6 - 1.5 l/h
Fuel Supply	Connections for external or vehicle fuel tank
Frame / Mounting	Generator mounted inside sound insulated capsule
Cooling System	external radiator and fan unit in housing for cooling
Instrumentation & Electrical	Panel mounted in APU + external slave panel
Approx APU weight (dry)	240 kg

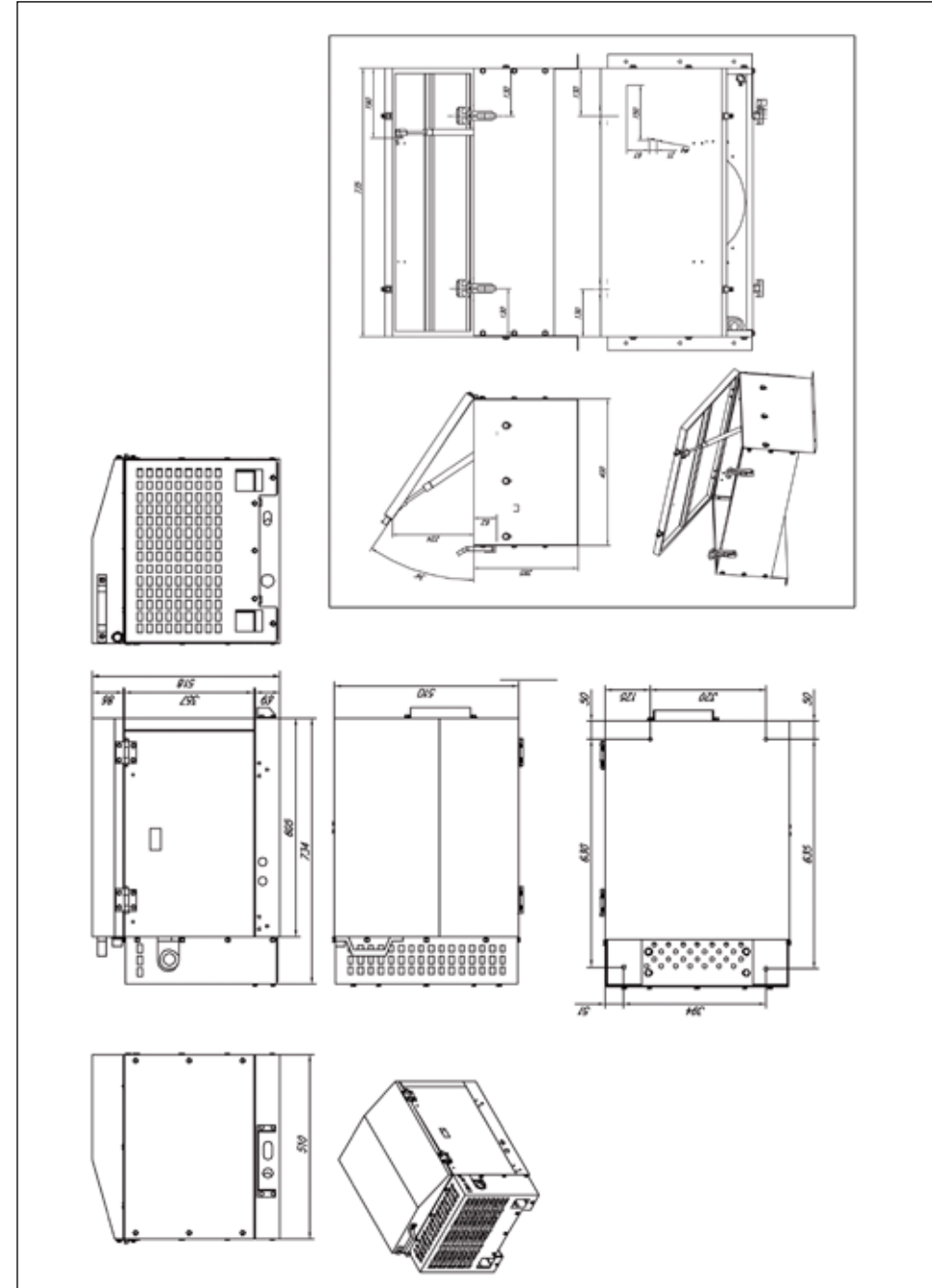

PANDA AGT 6000/24V PVMV-N



Generator	Panda AGT 6000/24V PVMV-N Water-cooled DC Generator
Constant Output	5,5 kW at sea level / +50°C
Output Voltage	24(28)V DC
Output Current	200A
Start System	24V Electrical
Engine Manufacturer	Kubota
Engine Type	Z 482
Engine Cylinders	2
Engine Operating Temp. Range	-32°C up to +50°C (other temperature ranges on request)
Fuel Types	F 34, F 54 „Standard automotive diesel fuel, kerosene, JP 8, JP 5, JET A
Approx. Fuel Consumption ¹⁾	0.6 - 2.0 l/h
Fuel Supply	Connections for external or vehicle fuel tank
Frame / Mounting	Generator mounted inside sound insulated capsule
Cooling System	Integrated radiator and fans mounted horizontally for cooling
Instrumentation & Electrical	Externally Mounted Panel
Approx APU weight (dry)	266 kg

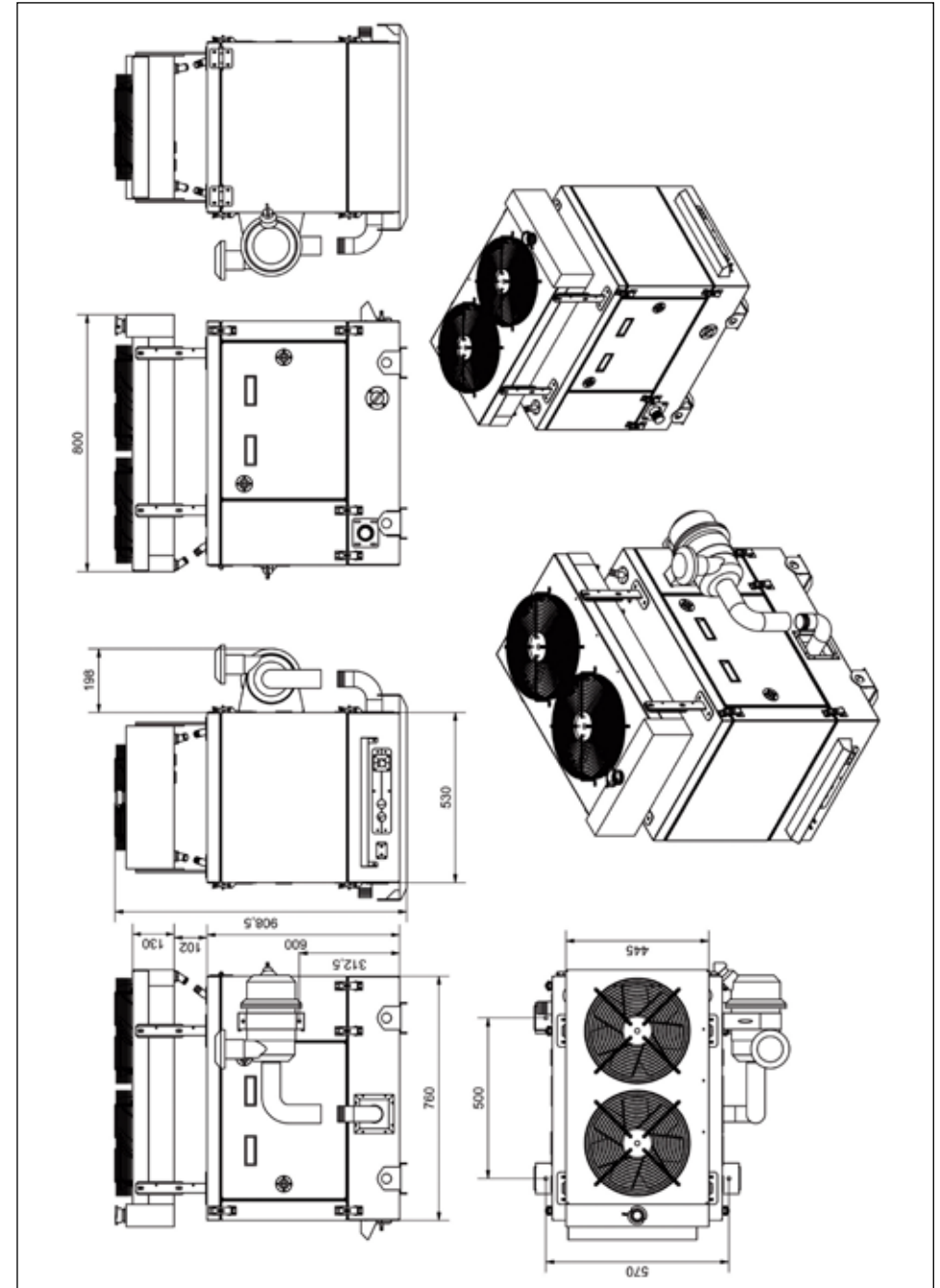

PANDA AGT 10000 PVM-NE



Generator	Panda AGT 10000 PVM-NE Water-cooled DC Generator
Constant Output	8,5 kW at 3000m / +50°C
Output Voltage	28V
Output Current	320A
Start System	24V Electrical
Engine Manufacturer	Kubota
Engine Type	D722 + Turbo
Engine Cylinders	3
Engine Operating Temp. Range	-32°C up to +55°C (other temperature ranges on request)
Fuel Types	F 34, F54, Standard automotive diesel fuel, kerosene, JP 8, JP 5, JET A
Approx. Fuel Consumption ¹⁾	0.6 - 3.0 l/h
Fuel Supply	Connections for external or vehicle fuel tank
Frame / Mounting	Unit mounted on frame
Cooling System	External radiator and fan unit in housing for cooling
Instrumentation & Electrical	External control box with remote control panel and instrumentation
Approx APU weight (dry)	266 kg without radiator

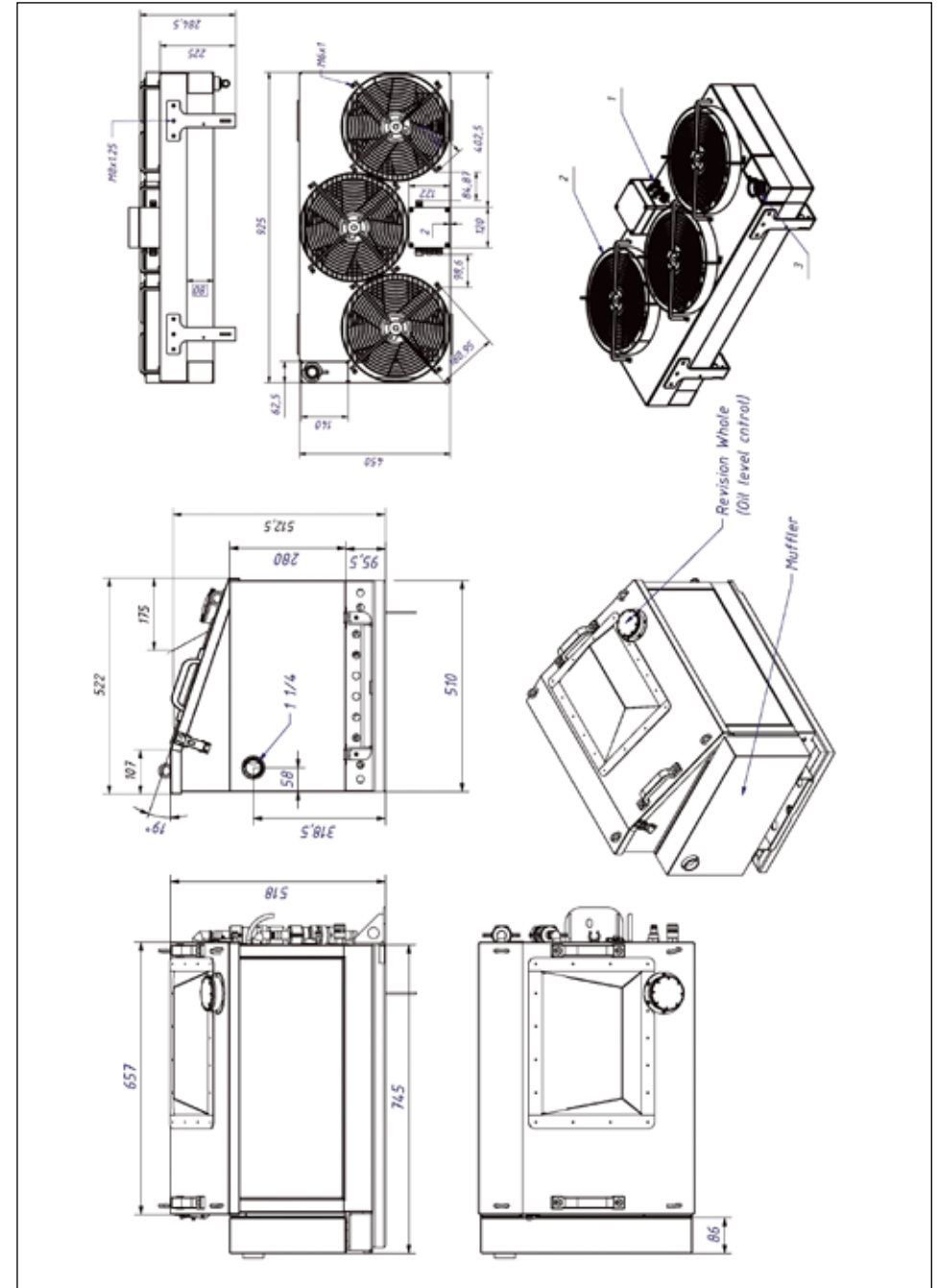

PANDA PU-2060N



Generator	Panda PU-2060N Water-cooled AC Generator
Constant Output	6 kW at 3000m / +50°C
Output Voltage	230V AC / 50 Hz single phase, optional 230V/400V/50Hz three phase
Output Current	26A
Start System	24V Electrical
Engine Manufacturer	Kubota
Engine Type	D722
Engine Cylinders	3
Engine Operating Temp. Range	-32°C up to +50°C (other temperature ranges on request)
Fuel Types	F 34, F 54 ,Standard automotive diesel fuel, kerosene, JP 8, JP 5, JET A
Approx. Fuel Consumption ¹⁾	0.9 - 2.2 l/h
Fuel Supply	Connections for external or vehicle fuel tank
Frame / Mounting	Generator mounted inside sound insulated capsule
Cooling System	External radiator and fan unit in housing for cooling
Instrumentation & Electrical	Externally Mounted Panel
Approx APU weight (dry)	277 kg

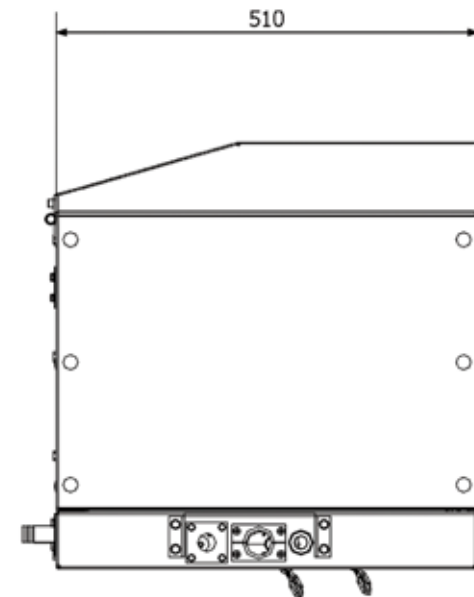
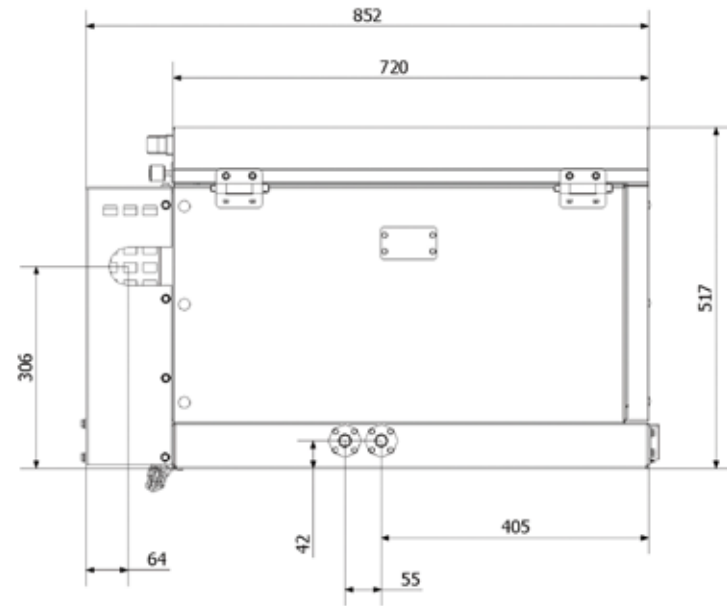

PANDA 8000 PSC



Generator	Panda 8000 PSC Water-cooled AC Generator
Constant Output	6,0 kW at 3000m / +50°C
Output Voltage	230V / 50 Hz
Output Current	26A
Start System	24V Electrical
Engine Manufacturer	Kubota
Engine Type	D722
Engine Cylinders	3
Engine Operating Temp. Range	-32°C up to +50°C (other temperature ranges on request)
Fuel Types	F 34, F54, Standard automotive diesel fuel, kerosene, JP 8, JP 5, JET A
Approx. Fuel Consumption ¹⁾	0.9 - 2.2 l/h
Fuel Supply	Connections for external or vehicle fuel tank
Frame / Mounting	Lifting bars under the generator
Cooling System	Integrated radiator and fans mounted for cooling
Instrumentation & Electrical	Integrated electrical cabinet
Approx APU weight (dry)	300 kg

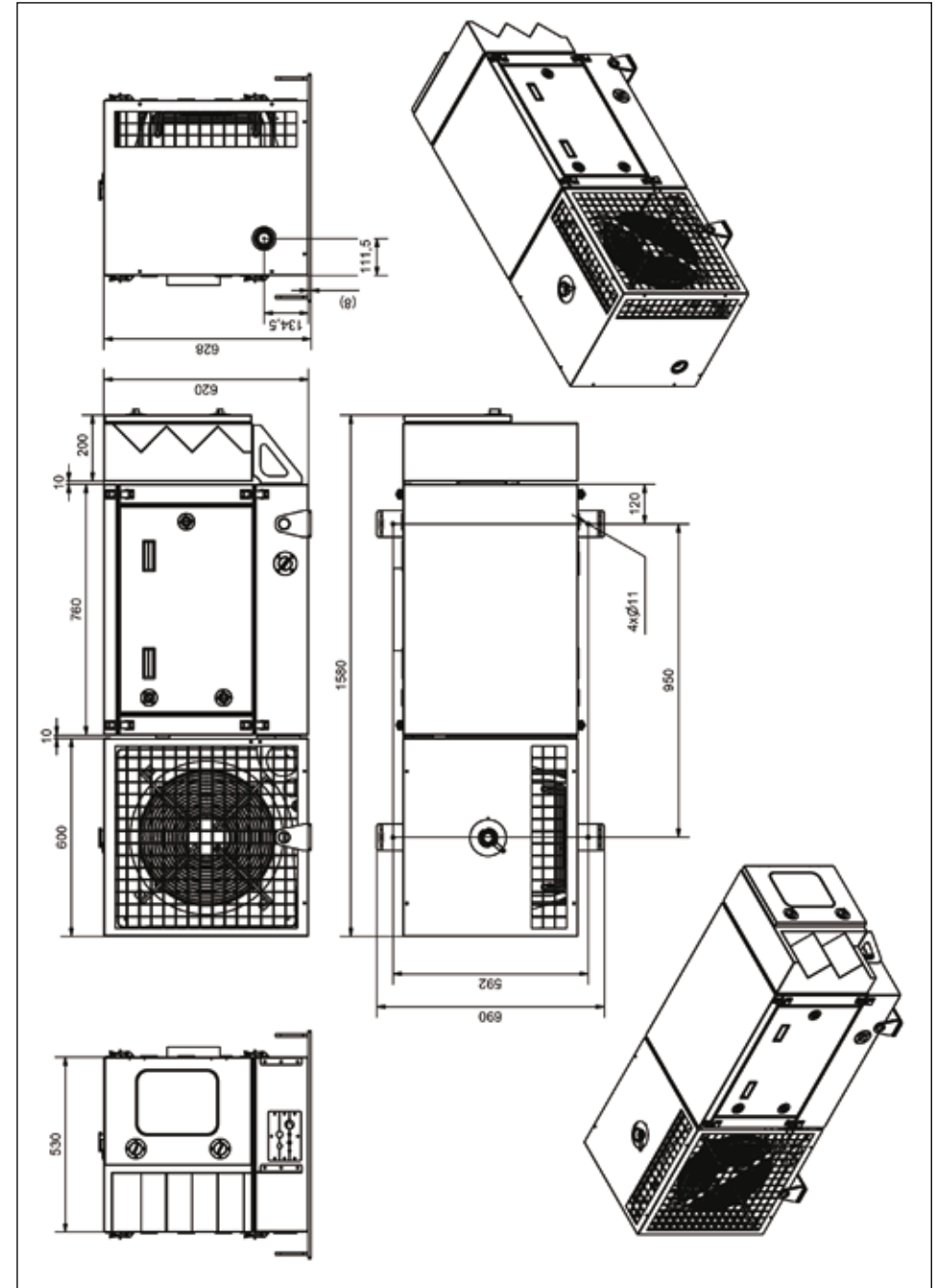

PANDA 8000 PSC-H



Generator	Panda 8000 PSC-H Water-cooled AC Generator with integrated radiator (tall version).
Constant Output	6 kW at 3000m / +50°C
Output Voltage	230V 50 Hz single phase, optional 230V/400V/50Hz three phase
Output Current	26A
Start System	24V Electrical
Engine Manufacturer	Kubota
Engine Type	D722
Engine Cylinders	3
Engine Operating Temp. Range	-32°C up to +50°C (other temperature ranges on request)
Fuel Types	F 34, F 54 ,Standard automotive diesel fuel, kerosene, JP 8, JP 5, JET A
Approx. Fuel Consumption ¹⁾	0.9 - 2.2 l/h
Fuel Supply	Integrated Fuel Tank (52 litre capacity)
Frame / Mounting	Self contained unit - slide mounted on rails with full extension
Cooling System	Integrated radiator and fans mounted horizontally for cooling
Instrumentation & Electrical	Integrated electrical cabinet with instruments and connections
Approx APU weight (dry)	467 kg

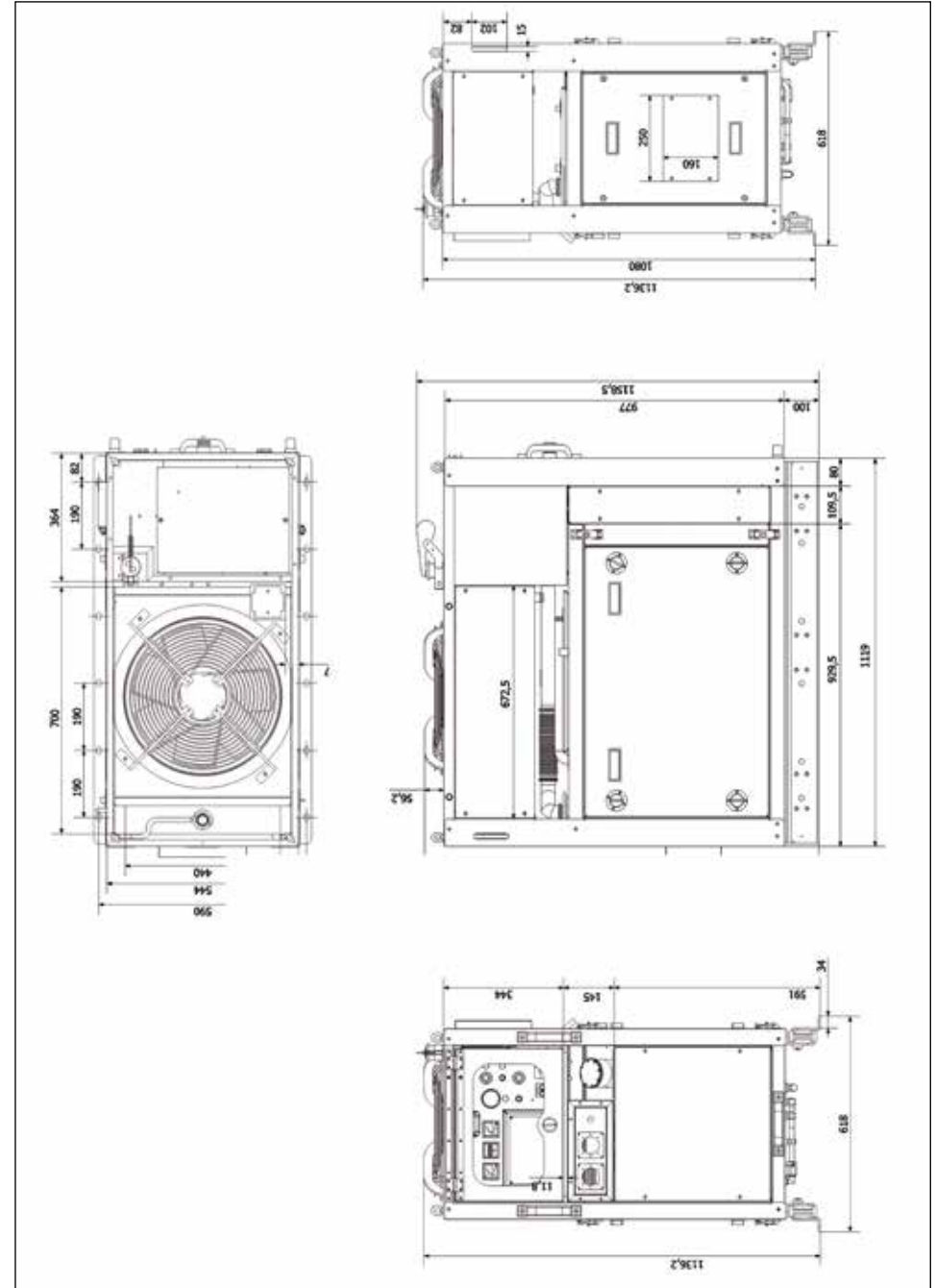

PANDA 8000 PSC



Generator	Panda 8000 PSC Water-cooled AC Generator
Constant Output	6 kW at 3000m / +50°C
Output Voltage	230V 50 Hz single phase, optional 230V/400V/50Hz three phase
Output Current	28A
Start System	24V Electrical
Engine Manufacturer	Kubota
Engine Type	D722
Engine Cylinders	3
Engine Operating Temp. Range	-32°C up to +50°C (other temperature ranges on request)
Fuel Types	F 34, F 54 ,Standard automotive diesel fuel, kerosene, JP 8, JP 5, JET A
Approx. Fuel Consumption ¹⁾	0.9 - 2.2 l/h
Fuel Supply	Integrated Fuel Tank (51 litre capacity)
Frame / Mounting	Unit mounted on frame with lifting eyes and fork lift pockets
Cooling System	Integrated radiator and fans mounted vertically for cooling
Instrumentation & Electrical	Integrated electrical cabinet with instruments and connections
Approx APU weight (dry)	571 kg

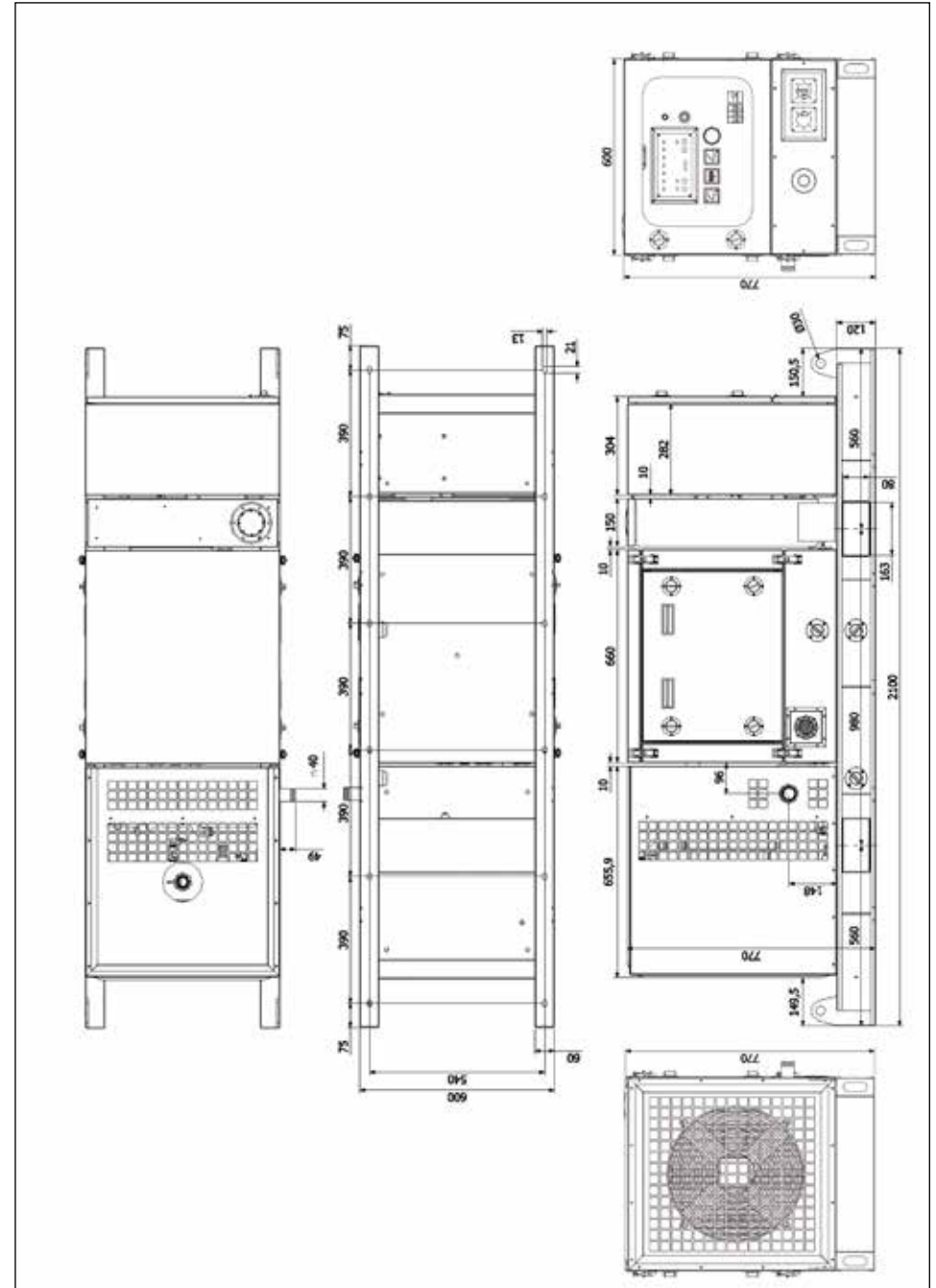

PANDA SST 10 TUNNEL



Generator	Panda SST 10 Tunnel Water-cooled AC Generator (HMMWV)
Constant Output	10 kW at 3000m / +50°C
Output Voltage	3x208 V 3-phase 60 Hz optional 120V/240V/60Hz or 230V/50Hz or 230V / 400V / 50Hz
Output Current	3x28A
Start System	24V Electrical
Engine Manufacturer	Kubota
Engine Type	D722 + Turbo
Engine Cylinders	3
Engine Operating Temp. Range	-32°C up to +50°C (other temperature ranges on request)
Fuel Types	F 34, F 54 ,Standard automotive diesel fuel, kerosene, JP 8, JP 5, JET A
Approx. Fuel Consumption ¹⁾	1.0 - 3.5 l/h
Fuel Supply	Connections for external or vehicle fuel tank
Frame / Mounting	Slide mounted on rails for installation in HUMVEE Shelter
Cooling System	Integrated radiator and fans for cooling
Instrumentation & Electrical	Externally Mounted Panel
Approx APU weight (dry)	340 kg

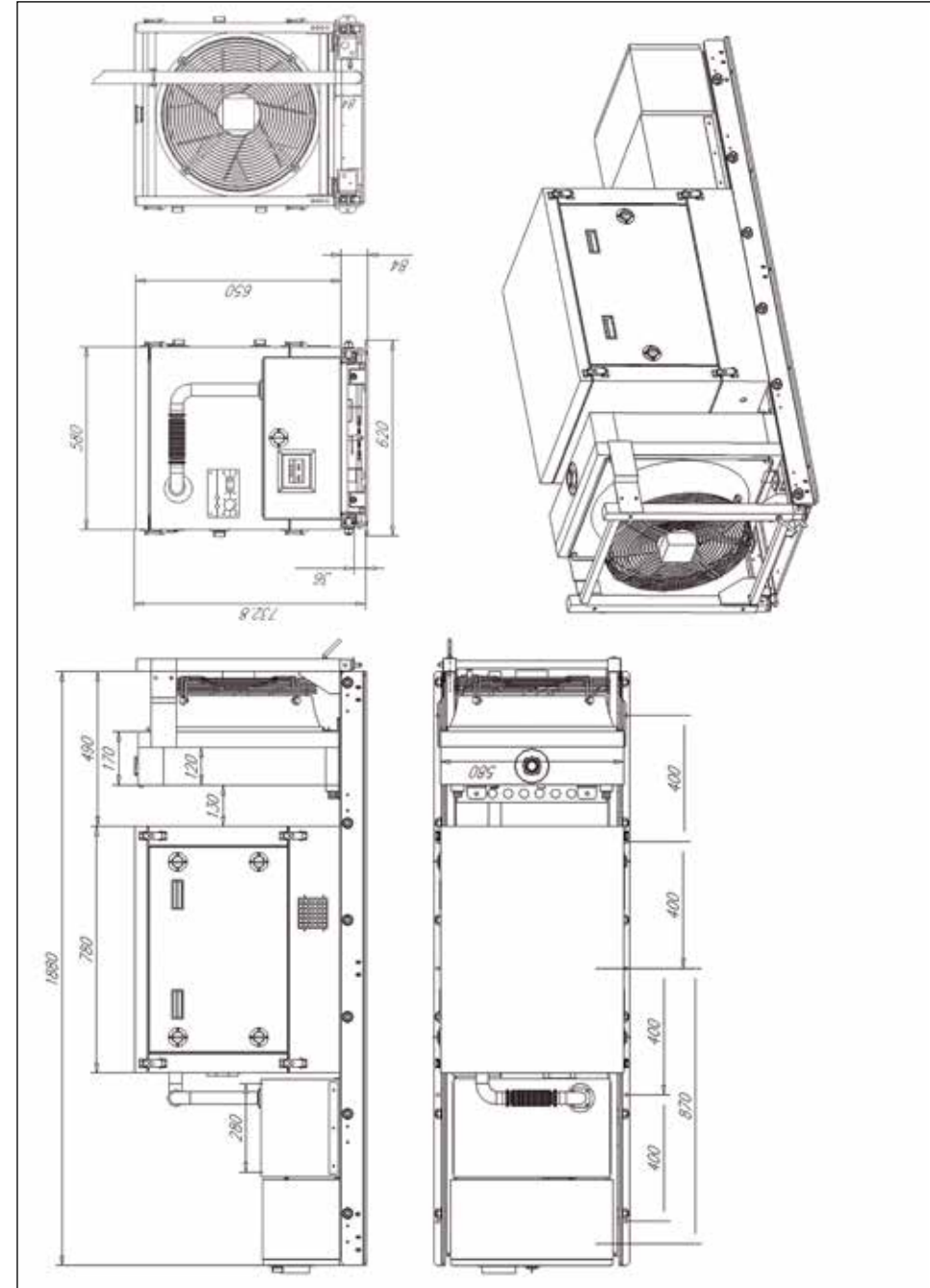

PANDA 12000 PSC



Generator	Panda 12000 PSC Water-cooled AC Generator
Constant Output	10 kW at sea level / +50°C
Output Voltage	230 V / 400 V 3-phase 50 Hz
Output Current	3x14A
Start System	24V Electrical
Engine Manufacturer	Kubota
Engine Type	D 722
Engine Cylinders	3
Engine Operating Temp. Range	-30°C up to +50°C (other temperature ranges on request)
Fuel Types	F 34, F 54 „Standard automotive diesel fuel, kerosene, JP 8, JP 5, JET A
Approx. Fuel Consumption ¹⁾	1.0 -3.5 l/h
Fuel Supply	Connections for external or vehicle fuel tank
Frame / Mounting	Self contained unit - slide mounted on rails
Cooling System	Integrated radiator and fans mounted vertically for cooling
Instrumentation & Electrical	Integrated electrical cabinet with instruments and connections
Approx APU weight (dry)	520 kg

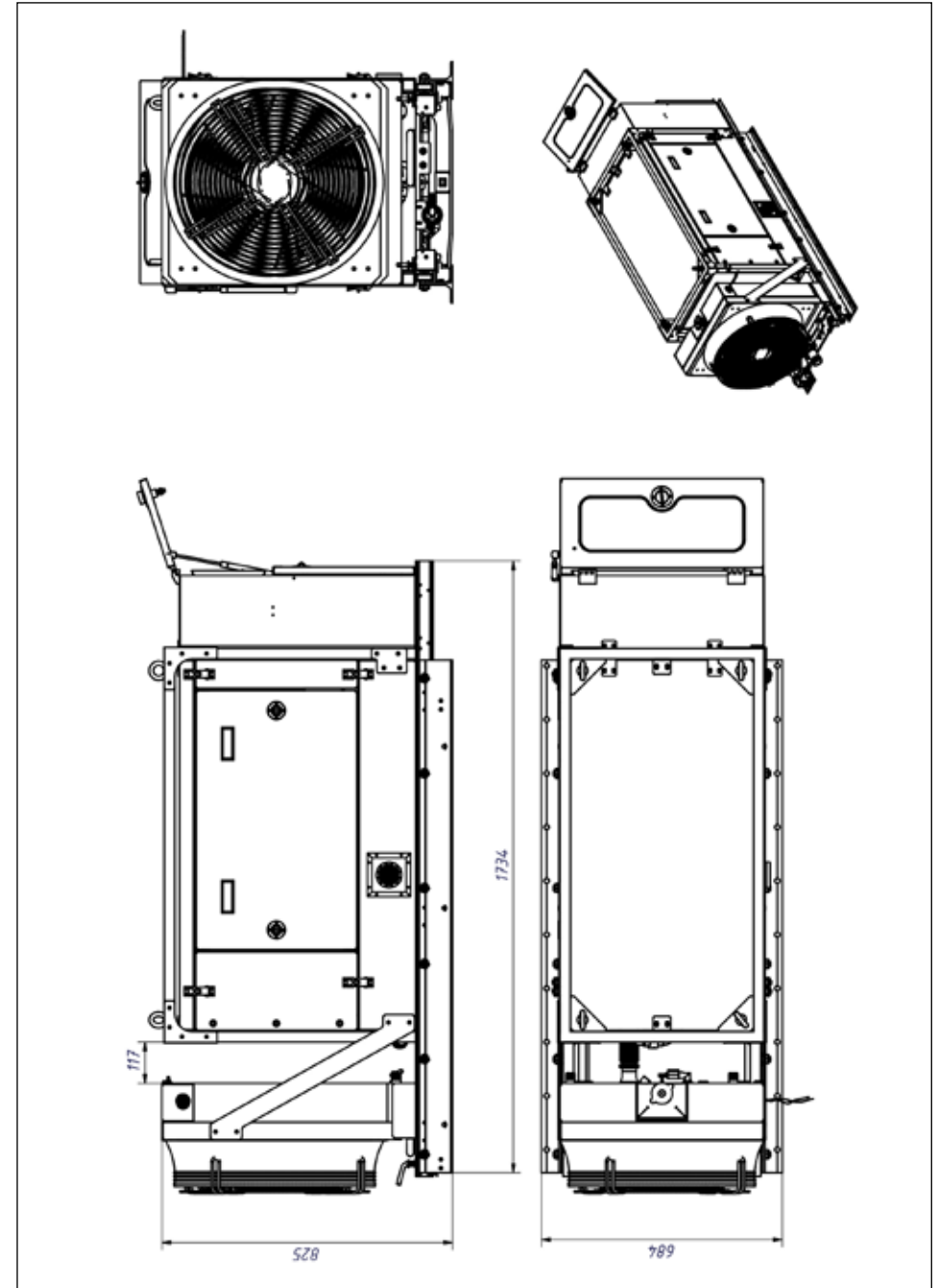

PANDA 15/10



Generator	Panda 15/10 Water-cooled AC Generator
Constant Output	10 kW at 3000m / +50°C
Output Voltage	220V / 380V / 50Hz
Output Current	3x16A
Start System	24V Electrical
Engine Manufacturer	Kubota
Engine Type	D1105
Engine Cylinders	3
Engine Operating Temp. Range	-32°C up to +50°C (other temperature ranges on request)
Fuel Types	F 34, F54, Standard automotive diesel fuel, kerosene, JP 8, JP 5, JET A
Approx. Fuel Consumption ¹⁾	1.5 - 3.5 l/h
Fuel Supply	Integrated Fuel Tank (45 litre capacity)
Frame / Mounting	Slide mounted on rails
Cooling System	Integrated radiator and fans mounted for cooling
Instrumentation & Electrical	External control box with remote control panel and instrumentation
Approx APU weight (dry)	778 kg

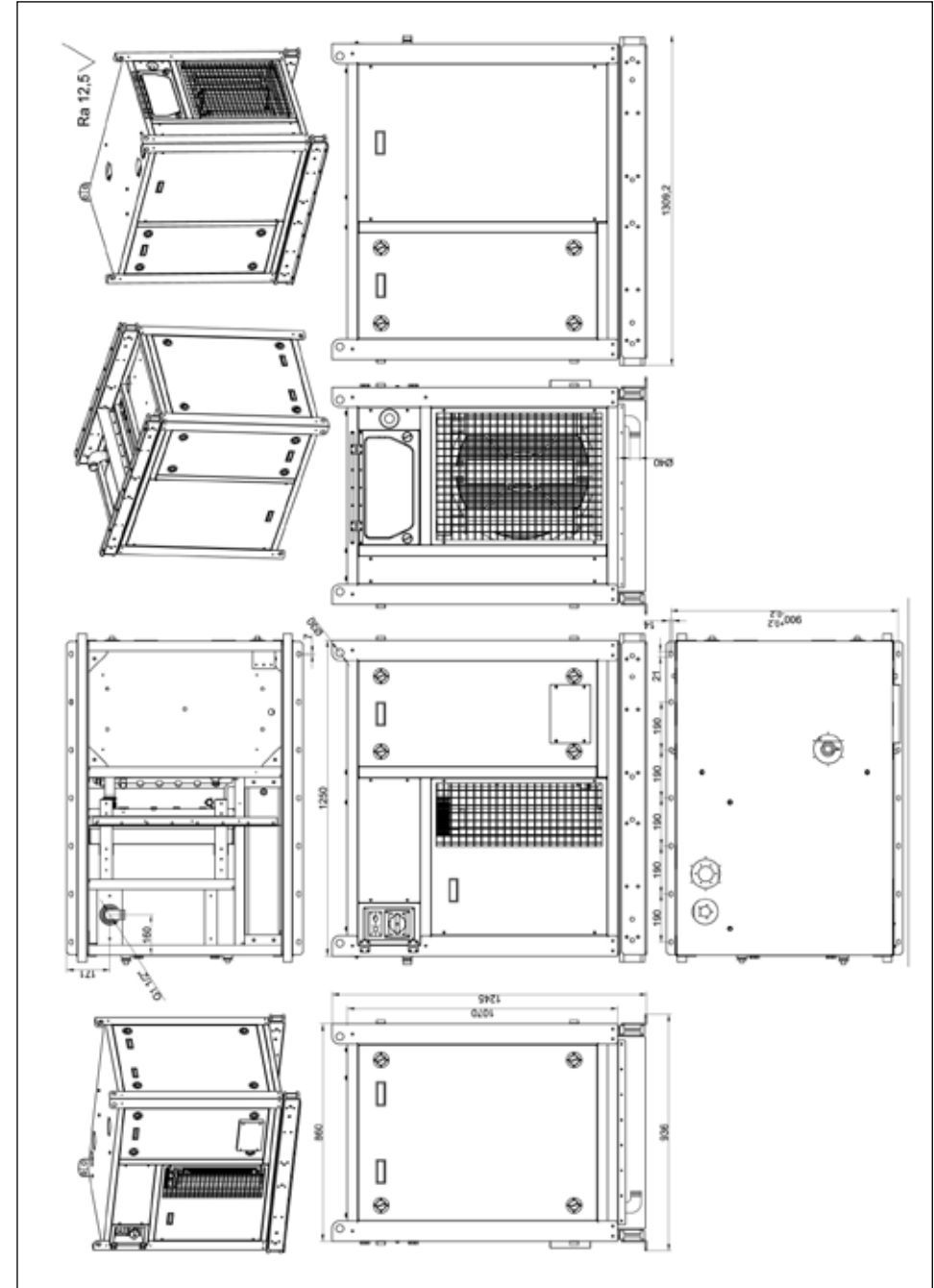

PANDA 15 PSC



Generator	Panda 15 PSC Water-cooled AC Generator
Constant Output	15 kW at 3000m / +50°C
Output Voltage	230V AC 50 Hz optional 230V / 400V / 50 Hz three phase
Output Current	62A / 17A
Start System	24V Electrical
Engine Manufacturer	Kubota
Engine Type	D902 + Turbo
Engine Cylinders	3
Engine Operating Temp. Range	-32°C up to +50°C (other temperature ranges on request)
Fuel Types	F 34, F 54 „Standard automotive diesel fuel, kerosene, JP 8, JP 5, JET A
Approx. Fuel Consumption ¹⁾	1.5 - 5.3 l/h
Fuel Supply	Integrated Fuel Tank (240 litre capacity)
Frame / Mounting	Self contained unit mounted on frame with lifting eyes
Cooling System	Integrated radiator and fans mounted vertically for cooling
Instrumentation & Electrical	Integrated electrical cabinet with instruments and connections
Approx APU weight (dry)	530 kg

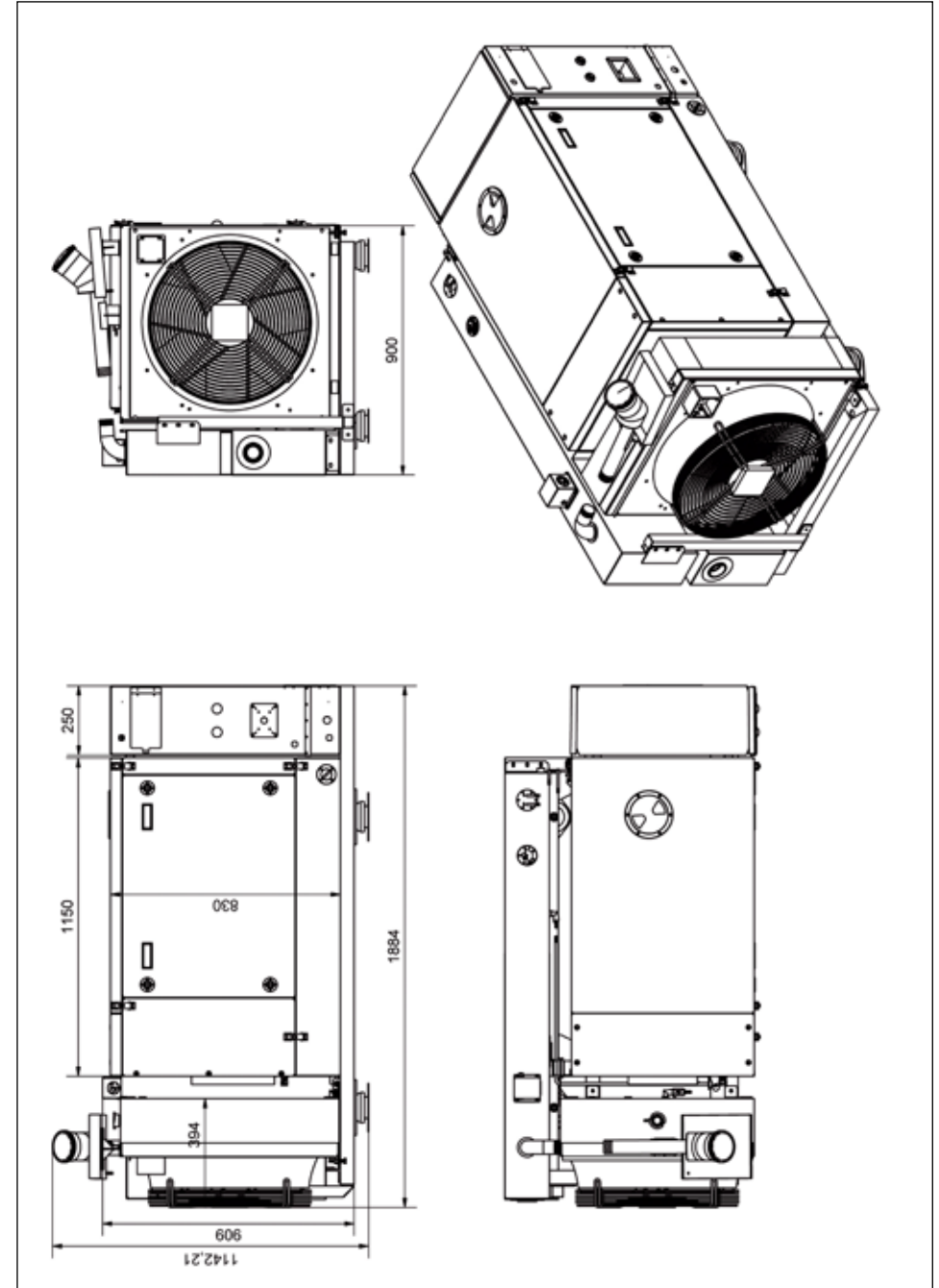

PANDA 15 PSC



Generator	Panda 15 PSC Water-cooled AC Generator
Constant Output	12,0 kW at sea level / +50°C
Output Voltage	230V / 400V / 50Hz
Output Current	3x17A
Start System	24V Electrical
Engine Manufacturer	Lombardini
Engine Type	LDW 1003
Engine Cylinders	3
Engine Operating Temp. Range	-32°C up to +50°C (other temperature ranges on request)
Fuel Types	F 34, F54, Standard automotive diesel fuel, kerosene, JP 8, JP 5, JET A
Approx. Fuel Consumption ¹⁾	1.5 - 4.2
Fuel Supply	Connections for external or vehicle fuel tank
Frame / Mounting	Complete unit mounted in a frame
Cooling System	Integrated radiator and fans mounted for cooling
Instrumentation & Electrical	19" rack with remote control panel and fast connectors for change
Approx APU weight (dry)	500 kg

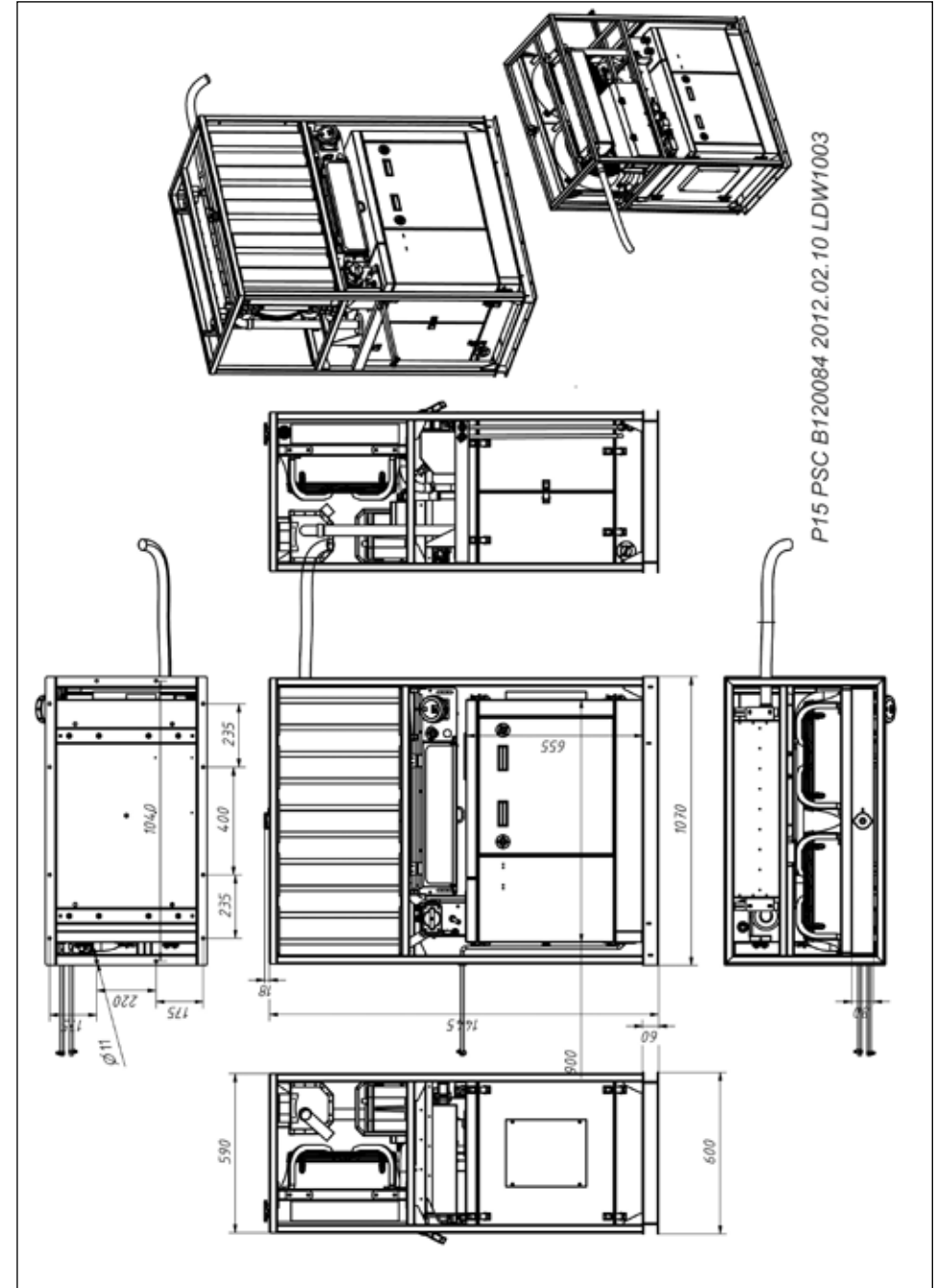

PANDA 18 PVM



Generator	Panda 18 PVM
	Water-cooled AC Generator
Constant Output	10 kW at 3000m / +50°C
Output Voltage	400V AC 50 Hz
Output Current	22,1A
Start System	24V Electrical
Engine Manufacturer	Kubota
Engine Type	D 1105
Engine Cylinders	3
Engine Operating Temp. Range	-32°C up to +50°C (other temperature ranges on request)
Fuel Types	F 34, F 54 „Standard automotive diesel fuel, kerosene, JP 8, JP 5, JET A
Approx. Fuel Consumption ¹⁾	1.5 - 3.5 l/h
Fuel Supply	Connections for external or vehicle fuel tank
Frame / Mounting	Generator mounted inside sound insulated capsule
Cooling System	External radiator and fan unit for cooling
Instrumentation & Electrical	Externally Mounted Panel
Approx APU weight (dry)	368 kg (without radiator)

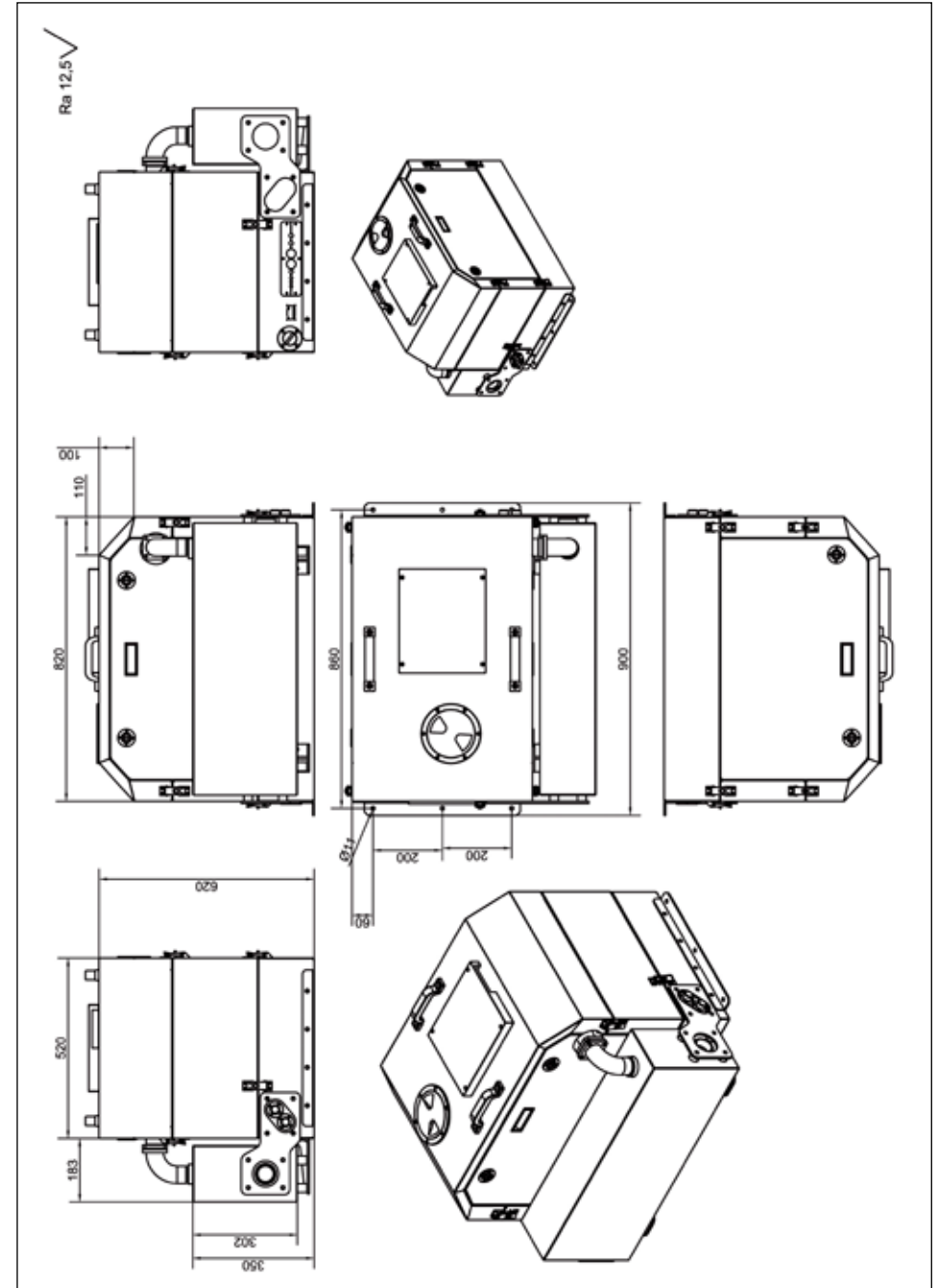

PANDA 18 PSC



Generator	Panda 18 PSC Water-cooled AC Generator
Constant Output	15 kW at 3000m / +50°C
Output Voltage	230 V / 400 V 3-phase 50 Hz
Output Current	3x21A
Start System	24V Electrical
Engine Manufacturer	Kubota
Engine Type	D 1105 T
Engine Cylinders	3
Engine Operating Temp. Range	-32°C up to +50°C (other temperature ranges on request)
Fuel Types	F 34, F 54 „Standard automotive diesel fuel, kerosene, JP 8, JP 5, JET A
Approx. Fuel Consumption ¹⁾	1.5 -5.3 l/h
Fuel Supply	Integrated Fuel Tank (120 litre capacity)
Frame / Mounting	Self contained unit mounted on skid-frame with fork lift pockets
Cooling System	Integrated radiator and fans mounted vertically for cooling
Instrumentation & Electrical	Integrated electrical cabinet with instruments and connections
Approx APU weight (dry)	650 kg

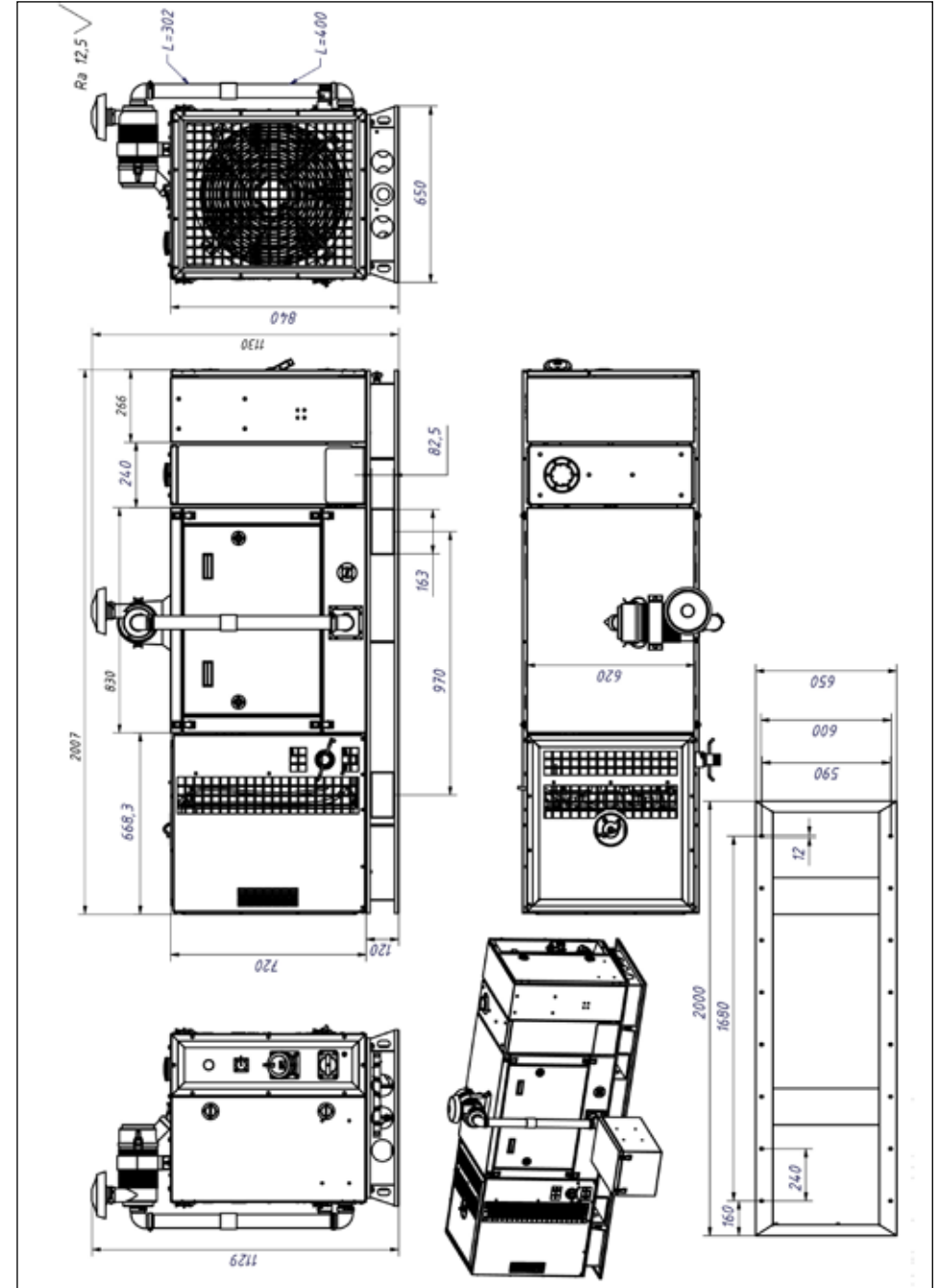

PANDA SST 18



Generator	Panda SST 18 Water-cooled AC Generator (HMMWV)
Constant Output	18 kW at 3000m / +50°C
Output Voltage	208 V 3-phase 60 Hz
Output Current	3x50A
Start System	24V Electrical
Engine Manufacturer	Kubota
Engine Type	V 1505T
Engine Cylinders	4
Engine Operating Temp. Range	-32°C up to +50°C (other temperature ranges on request)
Fuel Types	F 34, F 54 „Standard automotive diesel fuel, kerosene, JP 8, JP 5, JET A
Approx. Fuel Consumption ¹⁾	1.8 - 6.3 l/h
Fuel Supply	Connections for external or vehicle fuel tank
Frame / Mounting	Slide mounted on rails for installation in HUMVEE Shelter
Cooling System	Integrated radiator and fans mounted vertically for cooling
Instrumentation & Electrical	Integrated electrical cabinet with instruments and connections
Approx APU weight (dry)	560 kg

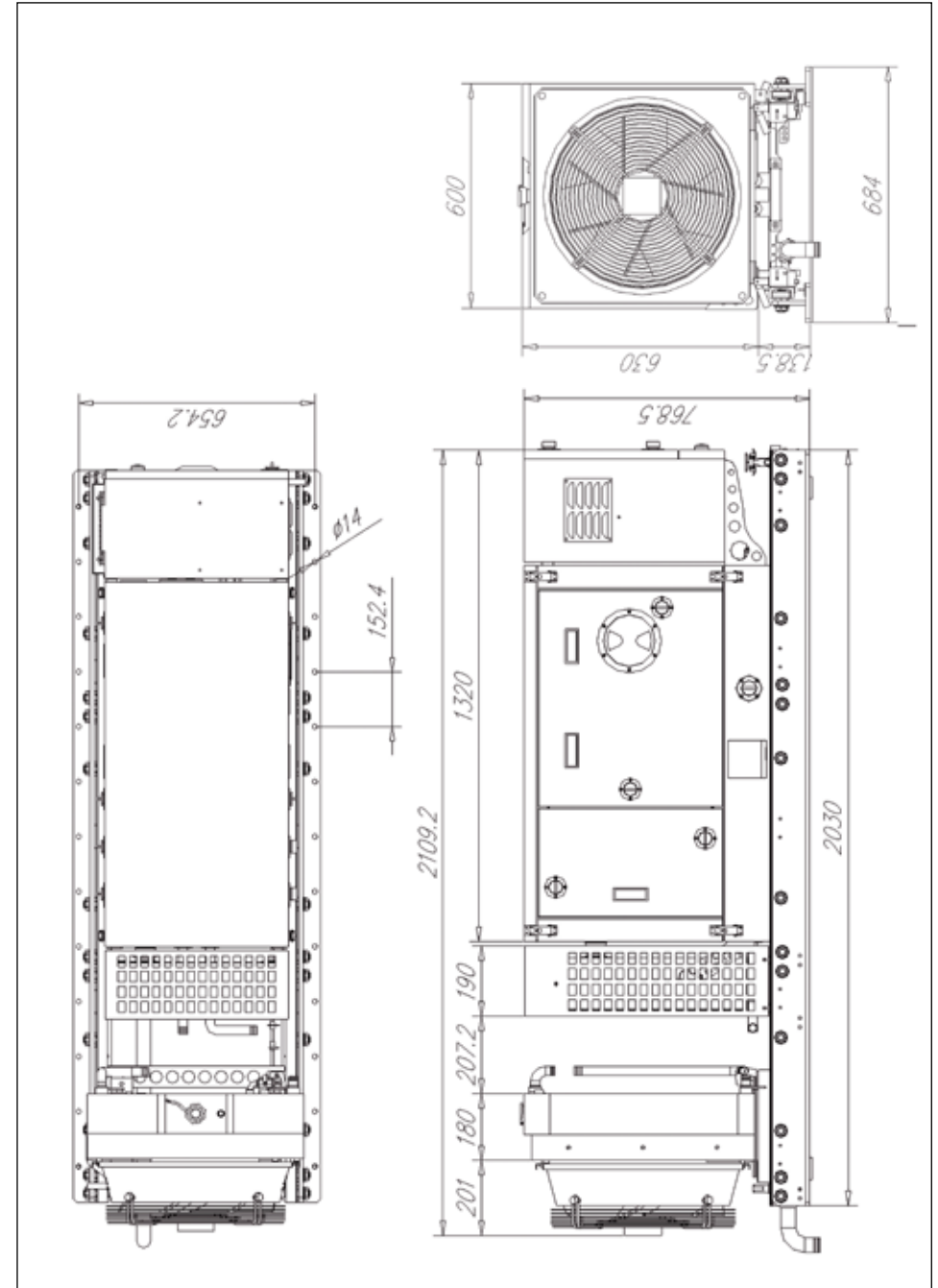

PANDA 24 PSC



Generator	Panda 24 PSC Water-cooled AC Generator
Constant Output	20,5 kW at sea level / +45°C
Output Voltage	230V / 400V / 50Hz
Output Current	3x29A
Start System	12V Electrical
Engine Manufacturer	Kubota
Engine Type	V 1505
Engine Cylinders	4
Engine Operating Temp. Range	-40 up to +45°C (other temperature ranges on request)
Fuel Types	F 34, F54, Standard automotive diesel fuel, kerosene, JP 8, JP 5, JET A
Approx. Fuel Consumption ¹⁾	1.8 - 7.2 l/h
Fuel Supply	Integrated Fuel Tank (90 litre capacity)
Frame / Mounting	Complete unit mounted on a frame
Cooling System	Integrated radiator and fans mounted for cooling
Instrumentation & Electrical	Integrated electrical cabinet
Approx APU weight (dry)	882 kg

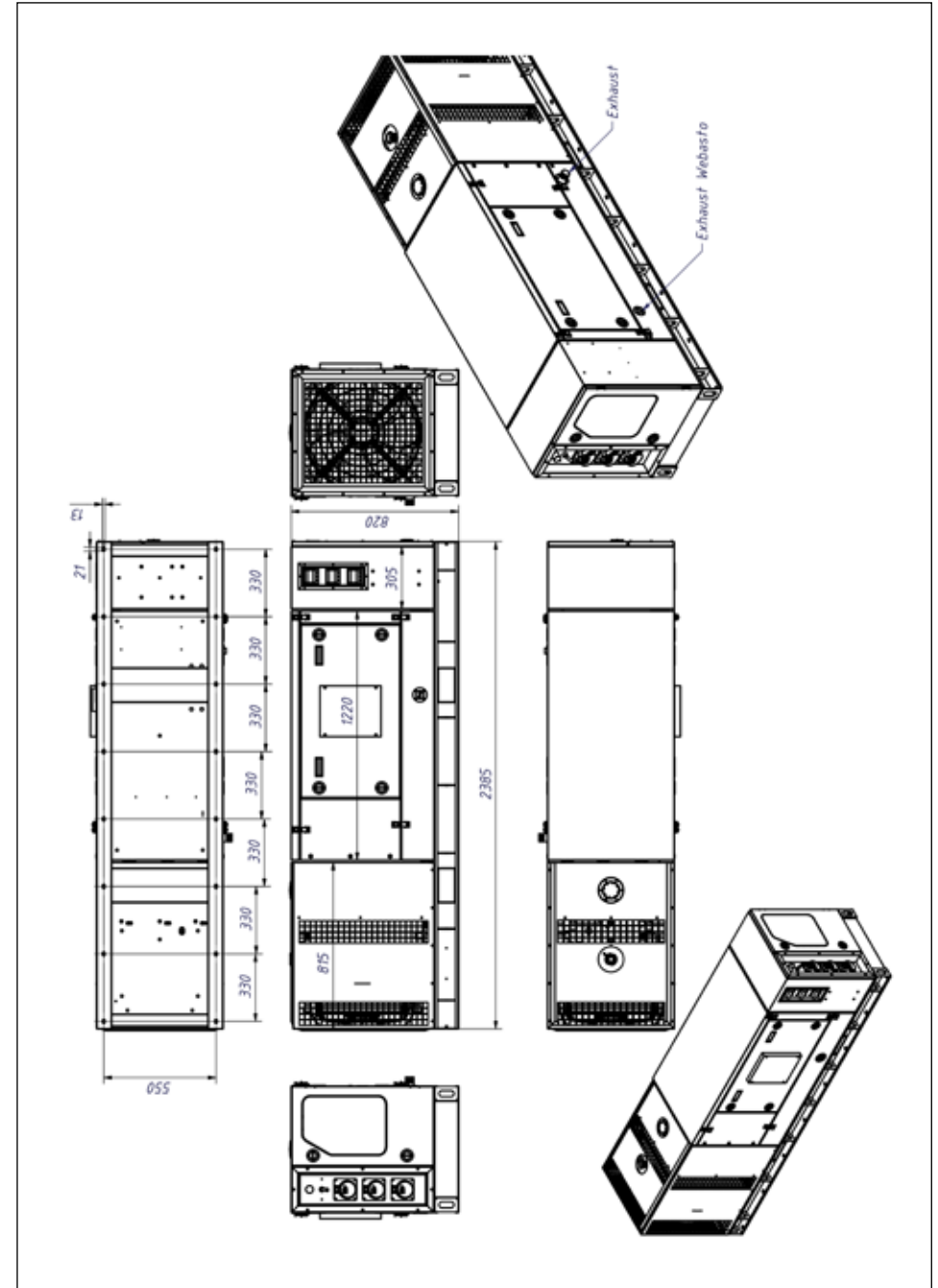

PANDA 30 PSC



Generator	Panda 30 PSC Water-cooled AC Generator
Constant Output	20 kW at 3000m / +50°C
Output Voltage	230V / 400V / 50 Hz
Output Current	3x30A
Start System	24V Electrical
Engine Manufacturer	Kubota
Engine Type	V 1505 T
Engine Cylinders	4
Engine Operating Temp. Range	-32°C up to +50°C (other temperature ranges on request)
Fuel Types	F 34, F 54 „Standard automotive diesel fuel, kerosene, JP 8, JP 5, JET A
Approx. Fuel Consumption ¹⁾	1.8 - 7.0 l/h
Fuel Supply	Integrated Fuel Tank (85 litre capacity)
Frame / Mounting	Self contained unit - slide mounted on rails
Cooling System	Integrated radiator and fan unit for cooling
Instrumentation & Electrical	Integrated electrical cabinet with instruments and connections
Approx APU weight (dry)	850 kg

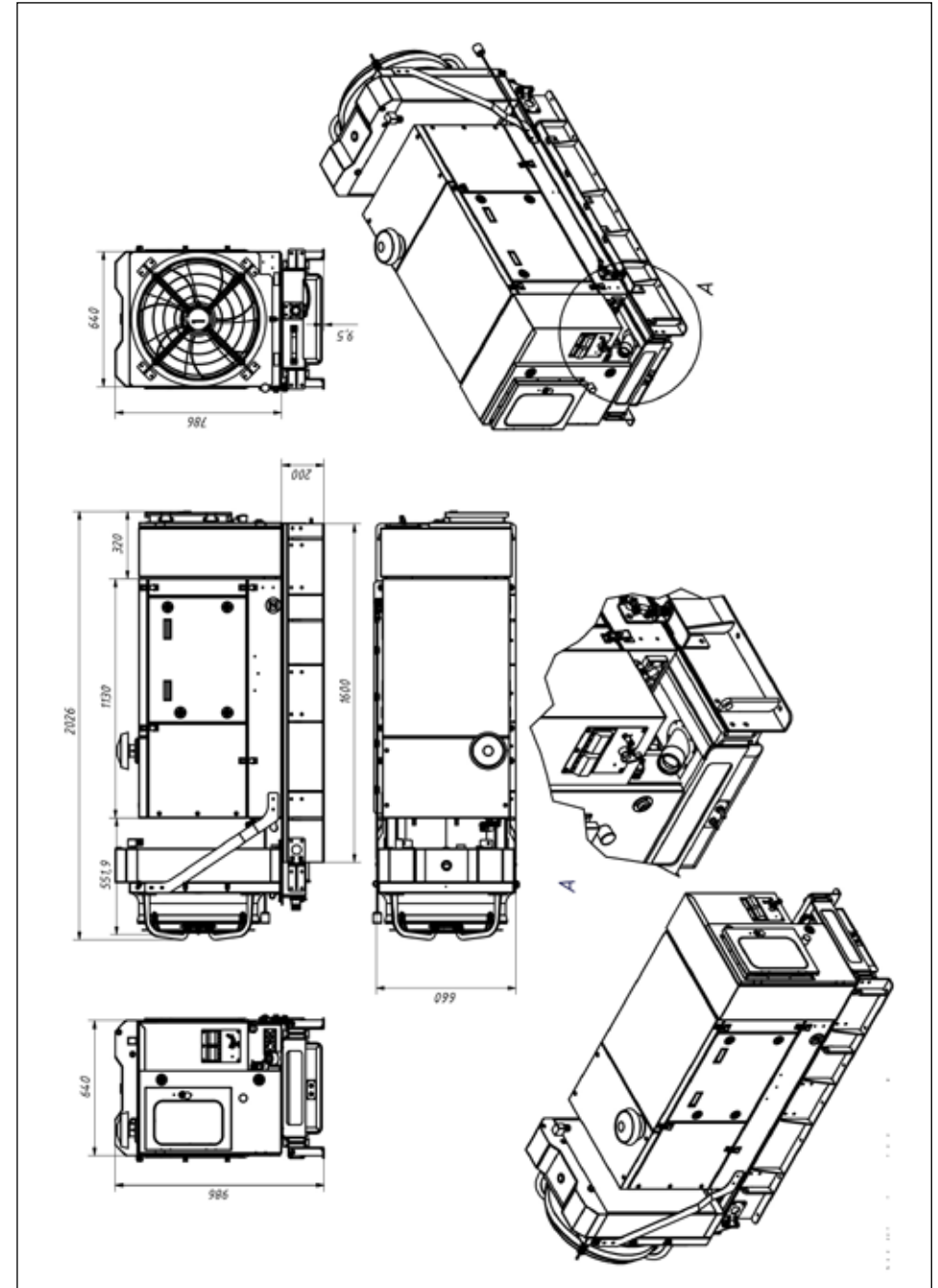

PANDA 30 PVMV-N



Generator	Panda 30 PVMV-N Water-cooled AC Generator
Constant Output	25,5 kW at sea level / +45°C
Output Voltage	230V / 400V / 50Hz
Output Current	3x36A
Start System	24V Electrical
Engine Manufacturer	Kubota
Engine Type	V 1505T
Engine Cylinders	4
Engine Operating Temp. Range	-40°C up to +45°C (other temperature ranges on request)
Fuel Types	F 34, F54, Standard automotive diesel fuel, kerosene, JP 8, JP 5, JET A
Approx. Fuel Consumption ¹⁾	1.8 - 9.0 l/h
Fuel Supply	Connections for external or vehicle fuel tank
Frame / Mounting	Generator mounted on a frame with fork lifter inlets
Cooling System	Integrated radiator and fans mounted for cooling
Instrumentation & Electrical	External remote control panel
Approx APU weight (dry)	750 kg

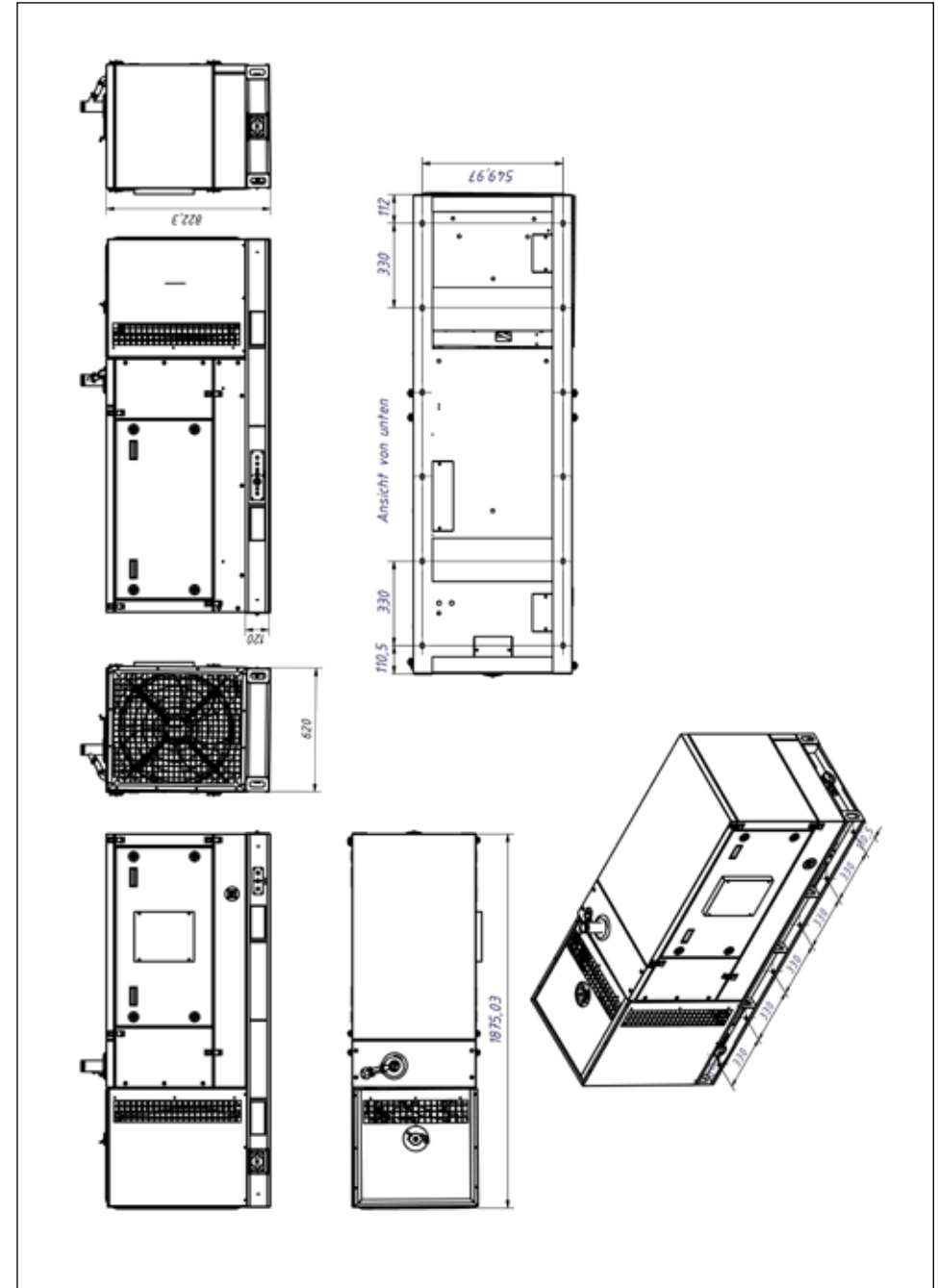

PANDA 30 PVMV-N



Generator	Panda 30 PVMV-N Water-cooled AC Generator
Constant Output	20 kW at 3000m / +50°C
Output Voltage	230/400V 50 Hz
Output Current	3x29A
Start System	24V Electrical
Engine Manufacturer	Kubota
Engine Type	V 1505 T
Engine Cylinders	4
Engine Operating Temp. Range	-32°C up to +50°C (other temperature ranges on request)
Fuel Types	F 34, F 54 „Standard automotive diesel fuel, kerosene, JP 8, JP 5, JET A
Approx. Fuel Consumption ¹⁾	1.8 - 7.0 l/h
Fuel Supply	Connections for external or vehicle fuel tank
Frame / Mounting	Unit mounted on frame
Cooling System	Integrated radiator and fans mounted vertically for cooling
Instrumentation & Electrical	Integrated electrical cabinet with instruments and connections
Approx APU weight (dry)	580 kg

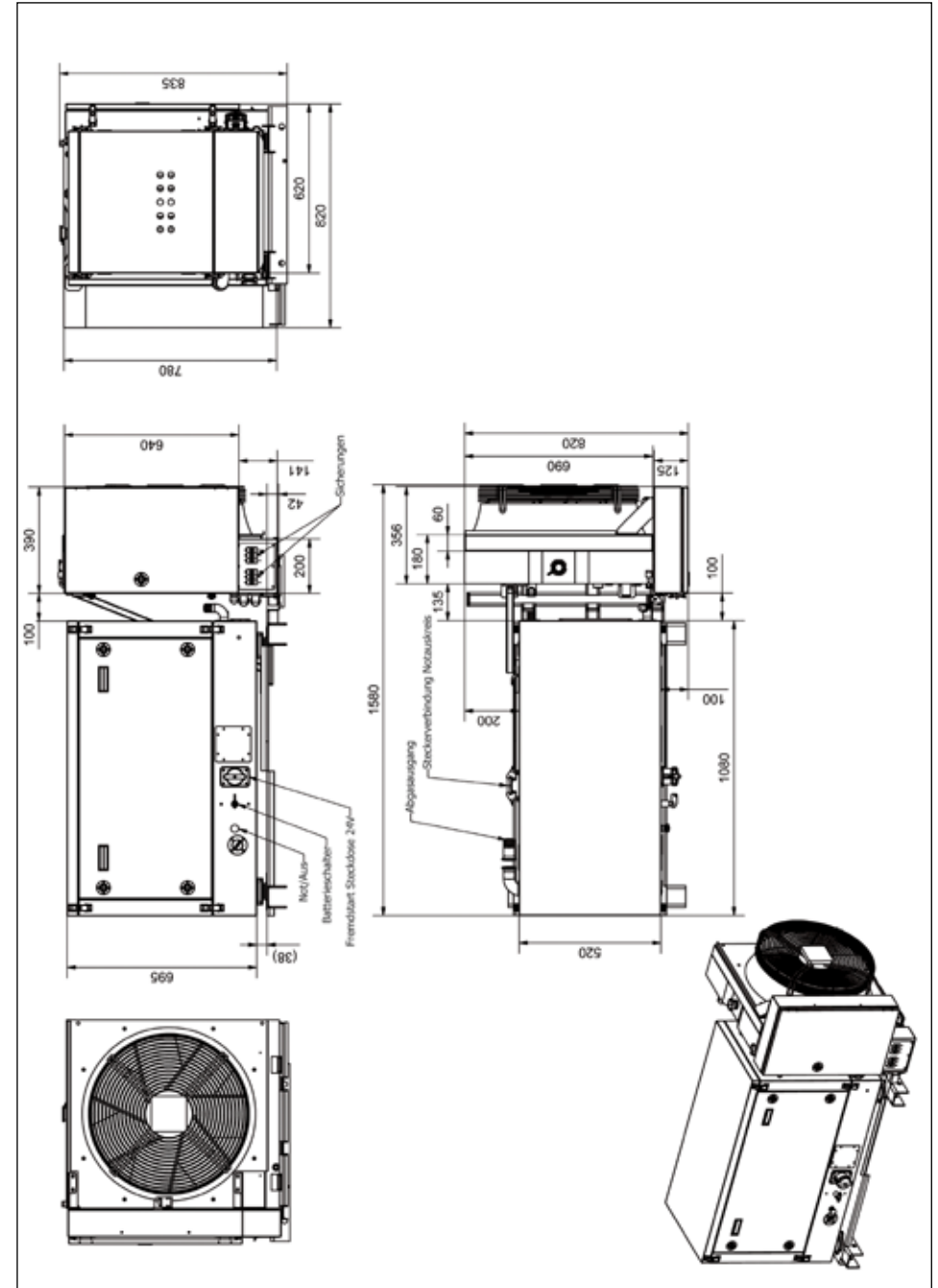

PANDA 40 Lom PSC



Generator	Panda 40 Lom PSC Water-cooled AC Generator
Constant Output	33kW at 3000m / +50°C
Output Voltage	230V / 400V / 50 Hz three phase
Output Current	3x47 A
Start System	24V Electrical
Engine Manufacturer	Lombardini
Engine Type	LDW2204/T GSE
Engine Cylinders	4
Engine Operating Temp. Range	-32°C up to +50°C (other temperature ranges on request)
Fuel Types	F 34, F 54 ,Standard automotive diesel fuel, kerosene, JP 8, JP 5, JET A
Approx. Fuel Consumption ¹⁾	4.2 - 12.0 l/h
Fuel Supply	Integrated Fuel Tank (125 litre capacity)
Frame / Mounting	Unit mounted on frame with lifting eyes and fork lift pockets
Cooling System	Integrated radiator and fans mounted horizontally for cooling
Instrumentation & Electrical	Integrated electrical cabinet with instruments and connections
Approx APU weight (dry)	1049 kg

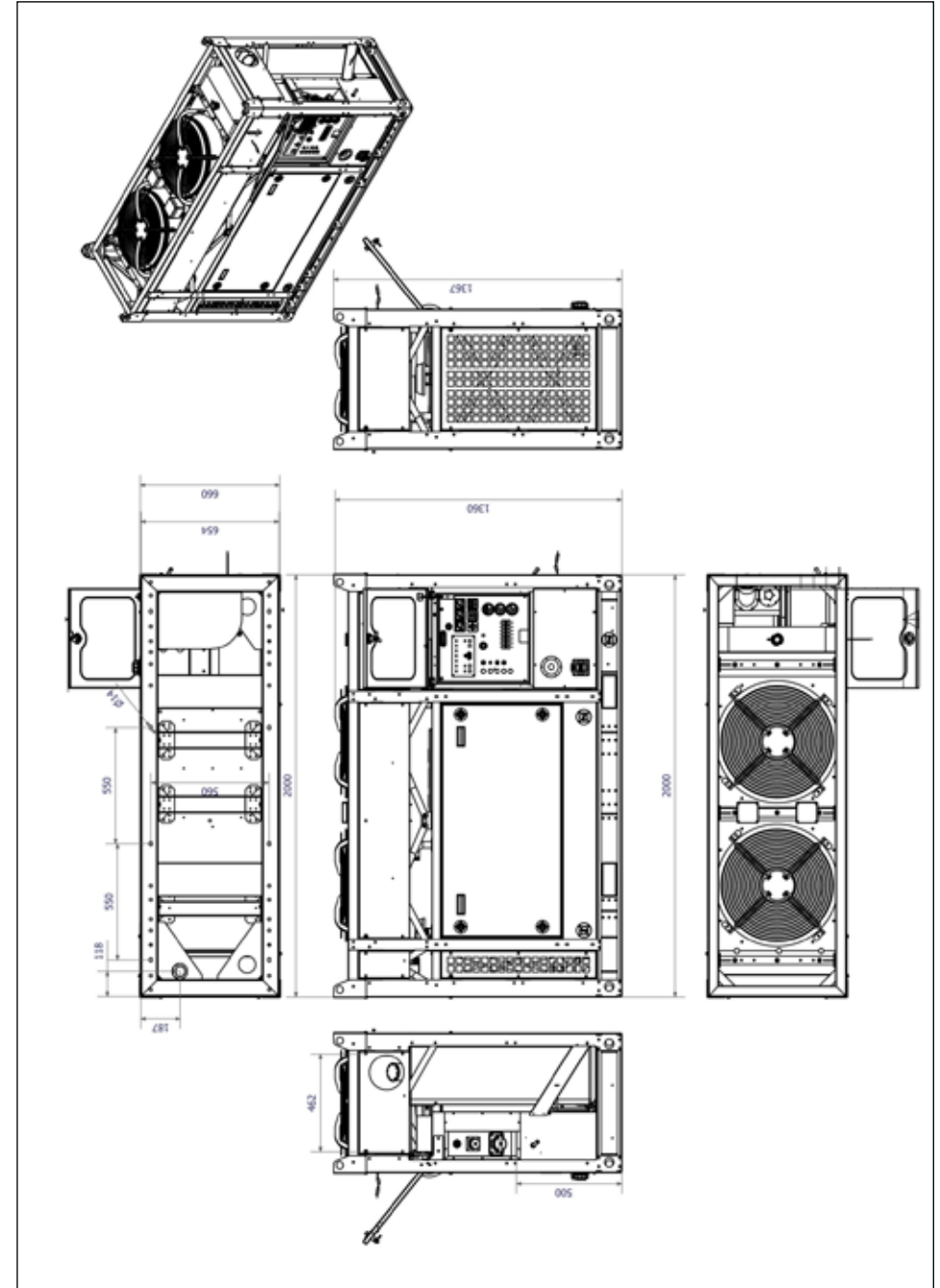

PANDA 47 Lom PSC



Generator	Panda 47 Lom PSC Water-cooled AC Generator (Tactical Shelter)
Constant Output	33kW at 3000m / +50°C
Output Voltage	230V / 400 / 50 Hz three phase
Output Current	3x47A
Start System	24V Electrical
Engine Manufacturer	Lombardini
Engine Type	LDW2204/T GSE
Engine Cylinders	4
Engine Operating Temp. Range	-32°C up to +50°C (other temperature ranges on request)
Fuel Types	F 34, F 54 „Standard automotive diesel fuel, kerosene, JP 8, JP 5, JET A
Approx. Fuel Consumption ¹⁾	4.2 - 12.0 l/h
Fuel Supply	Integrated Fuel Tank (100 litre capacity)
Frame / Mounting	Self contained unit - rail mounted on slides with forklift pockets
Cooling System	Integrated radiator and fans mounted horizontally for cooling
Instrumentation & Electrical	Integrated electrical cabinet with instruments and connections
Approx APU weight (dry)	1430 kg

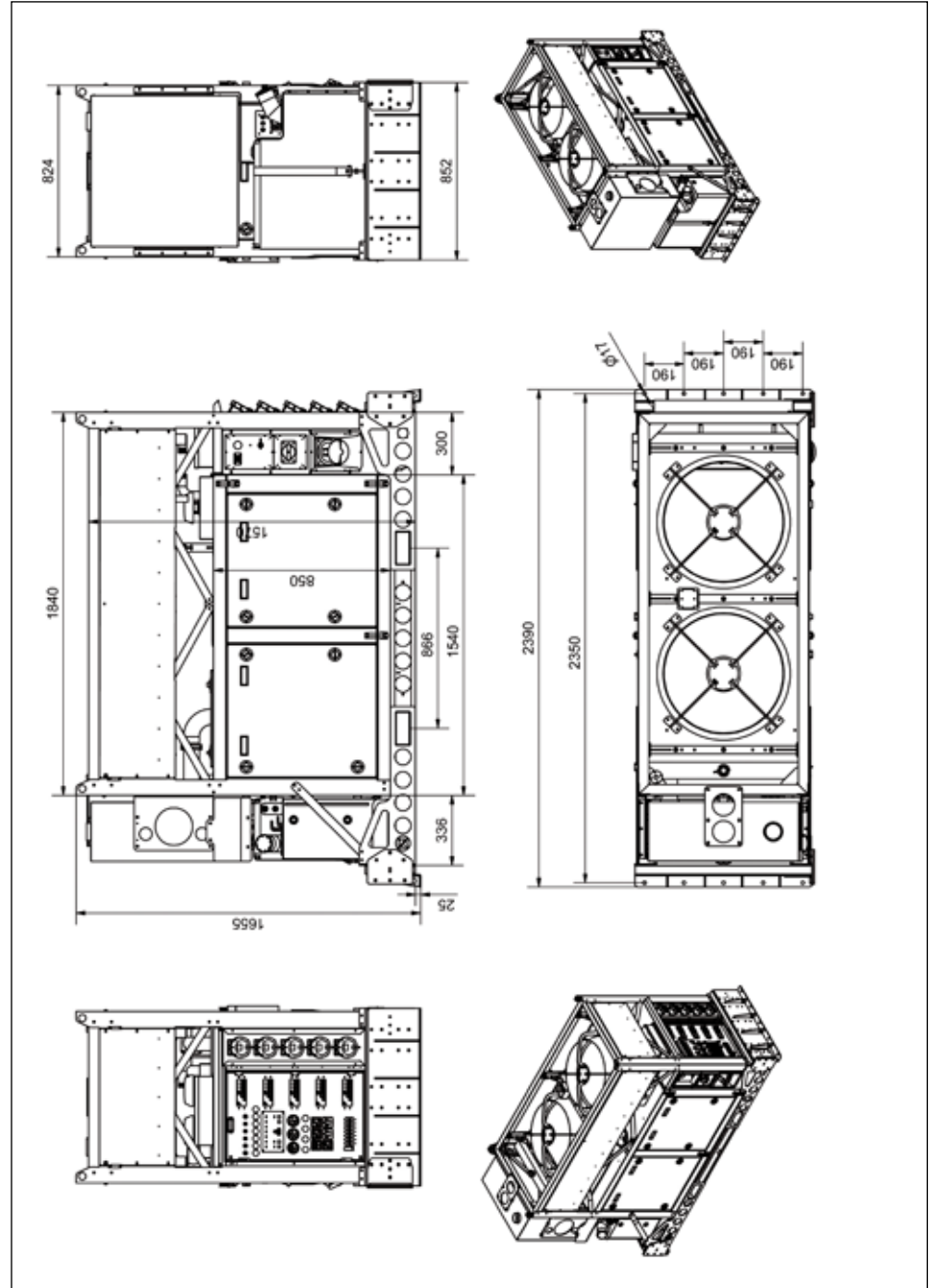

PANDA 65 PSC



Generator	Panda 65 PSC Water-cooled AC Generator (Tactical Shelter)
Constant Output	60 kW at 3000m / +50°C
Output Voltage	230V / 400V / 50 Hz three phase
Output Current	3x86A
Start System	24V Electrical
Engine Manufacturer	Mercedes
Engine Type	OM603A
Engine Cylinders	6
Engine Operating Temp. Range	-32°C up to +50°C (other temperature ranges on request)
Fuel Types	F 34, F 54 „Standard automotive diesel fuel, kerosene, JP 8, JP 5, JET A
Approx. Fuel Consumption ¹⁾	5.8 - 19.8 l/h
Fuel Supply	Integrated Fuel Tank (130 litre capacity)
Frame / Mounting	Self contained unit - rail mounted on slides with forklift pockets
Cooling System	Integrated radiator and fans mounted horizontally for cooling
Instrumentation & Electrical	Integrated electrical cabinet with instruments and connections
Approx APU weight (dry)	1694 kg

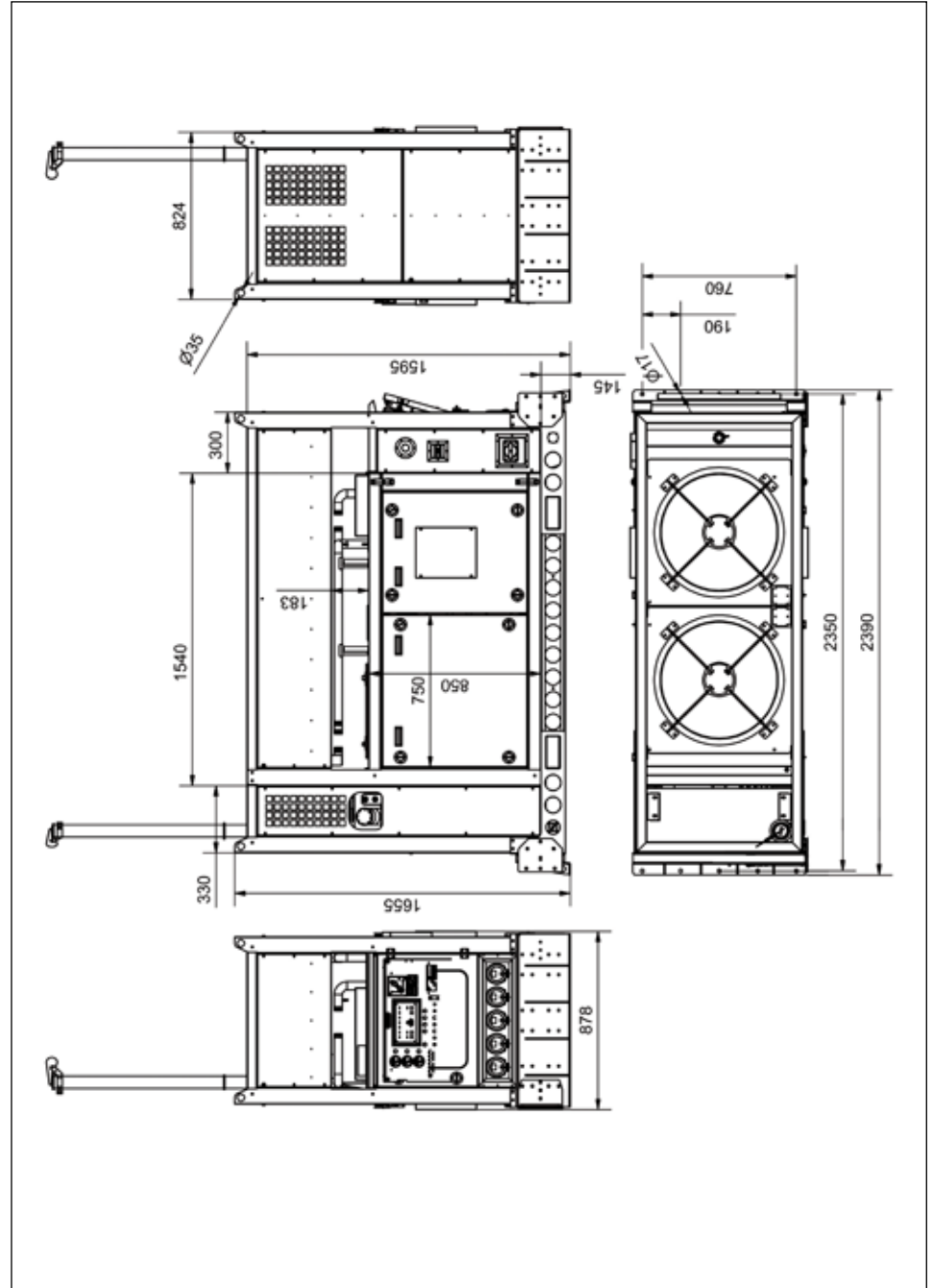

PANDA AGT 12000 PSC



Generator	Panda AGT 12000 PSC Water-cooled AC 400 Hz Generator
Constant Output	12,0 kW at 3000m / +50°C
Output Voltage	120V / 208 / 400 Hz or 240 / 416 / 400 Hz
Output Current	3x33A or 3x16.7A
Start System	24V Electrical
Engine Manufacturer	Kubota
Engine Type	D902 + Turbo
Engine Cylinders	3
Engine Operating Temp. Range	-32°C up to +50°C (other temperature ranges on request)
Fuel Types	F 34, F 54 „Standard automotive diesel fuel, kerosene, JP 8, JP 5, JET A
Approx. Fuel Consumption ¹⁾	1.0 - 4.2 l/h
Fuel Supply	Integrated Fuel Tank (70 litre capacity)
Frame / Mounting	Self contained unit - slide mounted on rails
Cooling System	Integrated radiator and fans mounted vertically for cooling
Instrumentation & Electrical	Integrated electrical cabinet with instruments and connections
Approx APU weight (dry)	530 kg

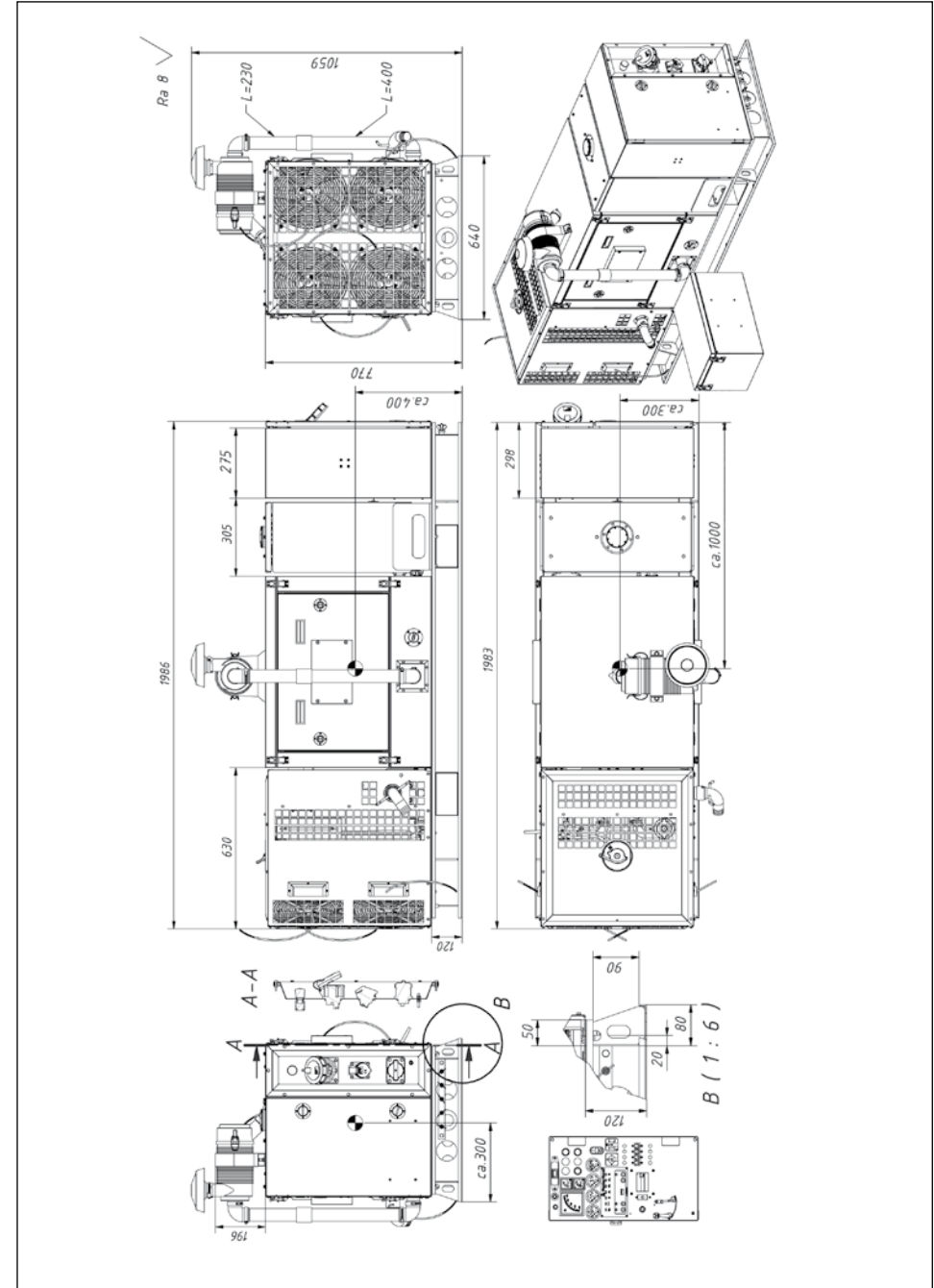

PANDA AGT 10000



Generator	Panda AGT 10000
	Water-cooled AC 400 Hz Generator (Balloon)
Constant Output	10 kW at 3000m / +50°C
Output Voltage	120V / 208V / 400Hz or 240V/416/400Hz
Output Current	3x28A or 3x14A
Start System	24V Electrical
Engine Manufacturer	Kubota
Engine Type	D722 + Turbo
Engine Cylinders	3
Engine Operating Temp. Range	-32°C up to +50°C (other temperature ranges on request)
Fuel Types	F 34, F 54 ,Standard automotive diesel fuel, kerosene, JP 8, JP 5, JET A
Approx. Fuel Consumption ¹⁾	1.0 -3.5 l/h
Fuel Supply	Connections for external supply
Frame / Mounting	Unit mounted on open frame
Cooling System	Integrated radiator and fans for cooling
Instrumentation & Electrical	Panel mounted on frame
Approx APU weight (dry)	222 kg

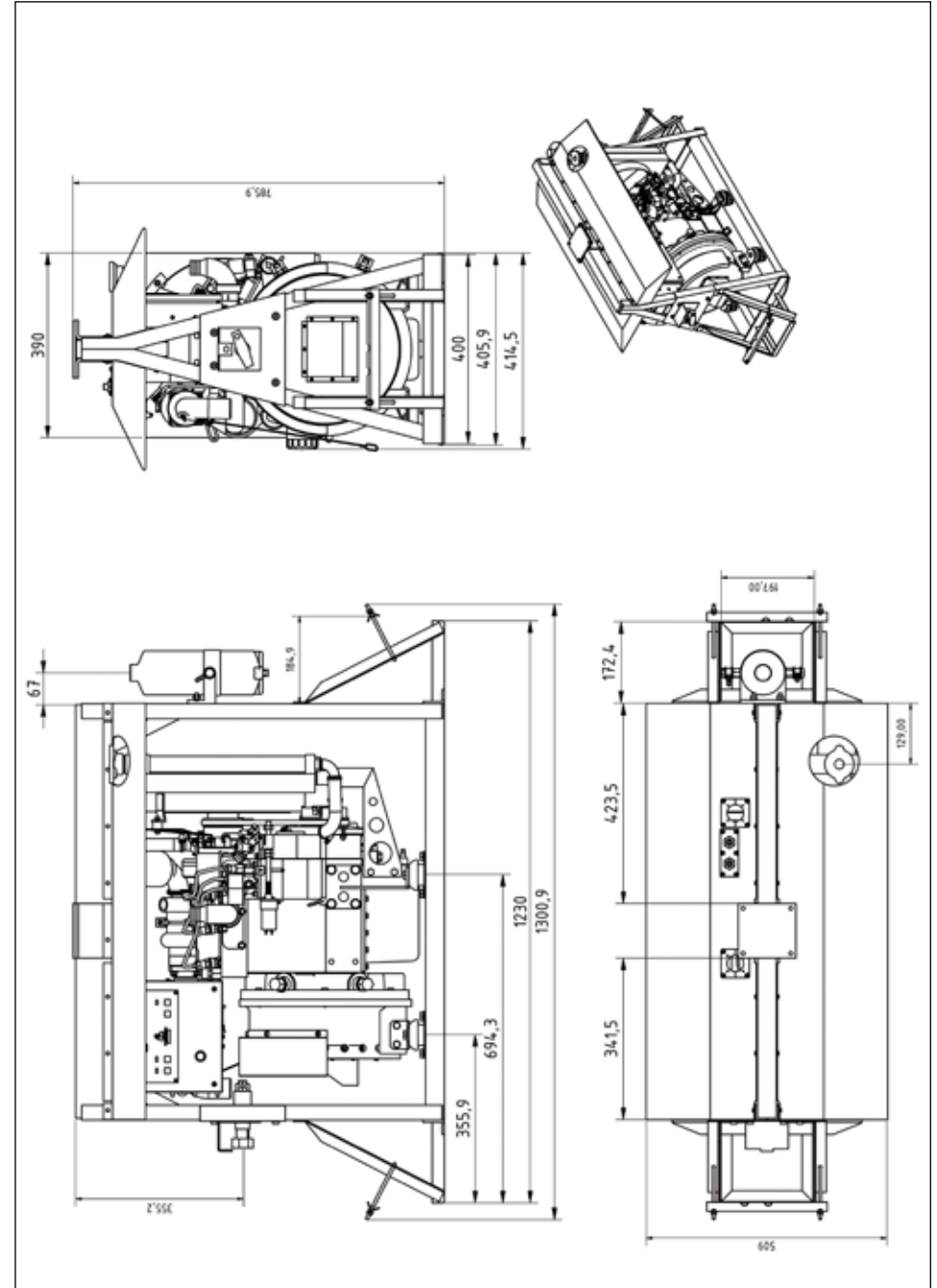

PANDA 10 SST COMBO



Generator	Panda 10 SST Combo Combo-Unit Generator + 18.000 BTU ECU (HMMWW)
Constant Output	10 kW electrical or 5kW + 4kW cooling at 3000m / +50°C
Output Voltage	230V / 400V / 50 Hz three phase
Output Current	3x14.5A
Start System	24V Electrical
Engine Manufacturer	Kubota
Engine Type	D722 + Turbo
Engine Cylinders	3
Engine Operating Temp. Range	-32°C up to +50°C (other temperature ranges on request)
Fuel Types	F 34, F 54 ,Standard automotive diesel fuel, kerosene, JP 8, JP 5, JET A
Approx. Fuel Consumption ¹⁾	1.0 - 3.5 l/h
Fuel Supply	Connections for external or vehicle fuel tank
Frame / Mounting	Slide mounted on rails for installation in HUMVEE Shelter
Cooling System	Integrated radiator and fans for cooling
Instrumentation & Electrical	Integrated electrical cabinet with instruments and connections
Approx APU weight (dry)	450 kg

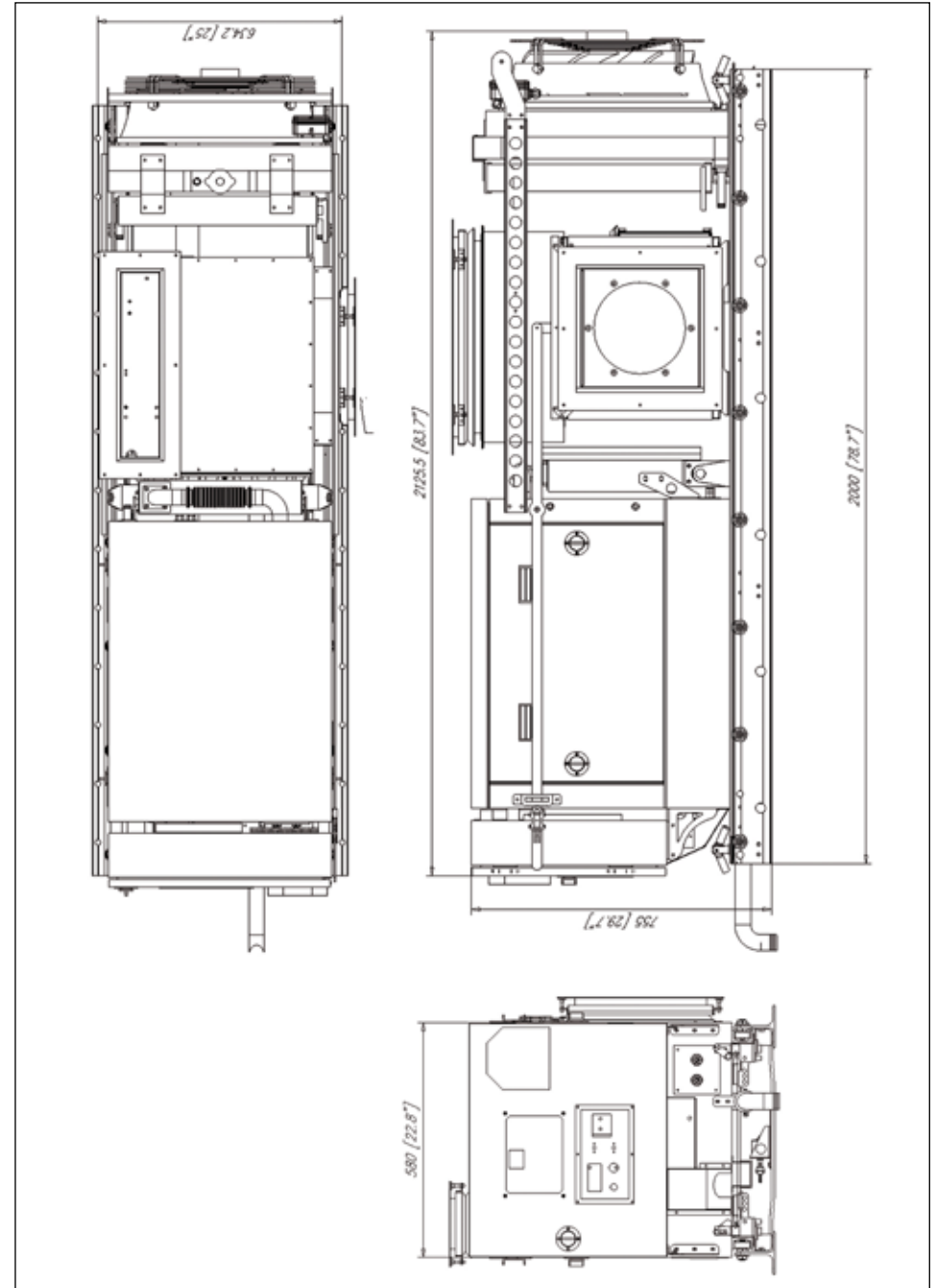

PANDA 12 SST COMBO



Generator	Panda 12 SST Combo Combo-Unit Generator + 24.000 BTU ECU (HMMWV)
Constant Output	12 kW electrical or 7kW + 5kW cooling at 3000m / +50°C
Output Voltage	230V / 400V / 50 Hz three phase
Output Current	3x17.4 A
Start System	24V Electrical
Engine Manufacturer	Kubota
Engine Type	D 902
Engine Cylinders	3
Engine Operating Temp. Range	-32°C up to +50°C (other temperature ranges on request)
Fuel Types	F 34, F 54 „Standard automotive diesel fuel, kerosene, JP 8, JP 5, JET A
Approx. Fuel Consumption ¹⁾	1.0 - 4.2 l/h
Fuel Supply	Connections for external or vehicle fuel tank
Frame / Mounting	Slide mounted on rails for installation in HUMVEE Shelter
Cooling System	Integrated radiator and fans for cooling
Instrumentation & Electrical	Integrated electrical cabinet with instruments and connections
Approx APU weight (dry)	470 kg

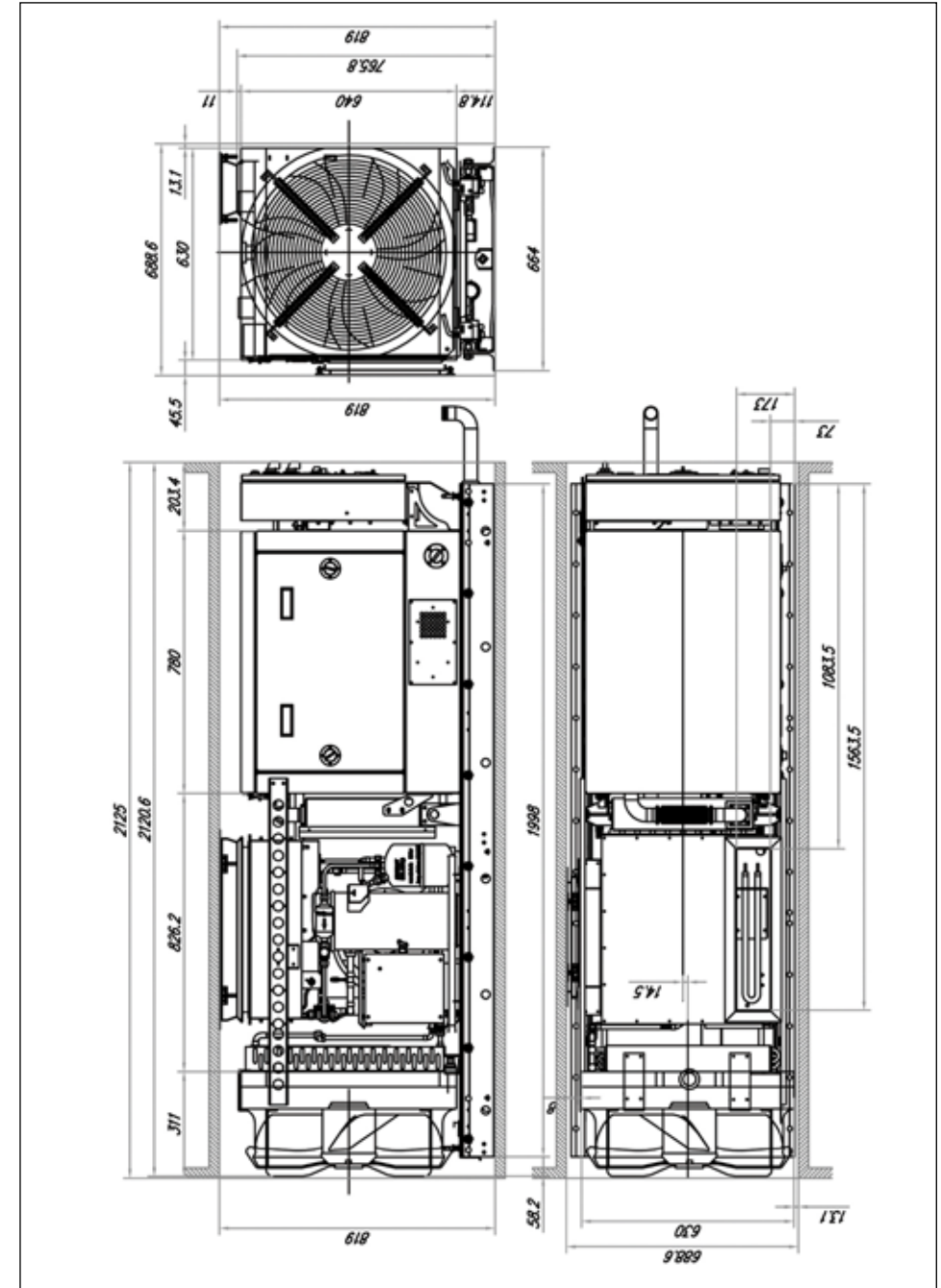

PANDA 30 CAPS



Generator	Panda 30 CAPS
	Combined generator + aircon + NBC filter+ heating # Built to comply with MIL STD 461E / MIL STD 810F # Ambient temperature – 46°C up to + 60°C
Constant Output	up to 20 kW elec. / 2 x 8kW cooling at 3000m / +50°C
Output Voltage	400 V 3-phase AC 50 Hz
Output Current	3x29 A
Start System	24V Electrical
Engine Manufacturer	Kubota
Engine Type	V 1505 T
Engine Cylinders	4-cylinder
Engine Operating Temp. Range	
Fuel Types	F 34, F54, Standard automotive diesel fuel, kerosene, JP 8, JP 5, JET A
Approx. Fuel Consumption ¹⁾	2.7 - 7.11 / h (7-8 l/h fully loaded)
Fuel Supply	Internal (approx. 100 litres) with connections for an external supply source
Frame / Mounting	Stackable Frame with quick-release connections designed for rapid setup
Cooling System	Integrated radiator and fans mounted for cooling
Instrumentation & Electrical	Features a fully external control unit for mounting within container. Early-warning alarm functions on sensors so operator can override according to operational state
Approx APU weight (dry)	approx. 2000kg

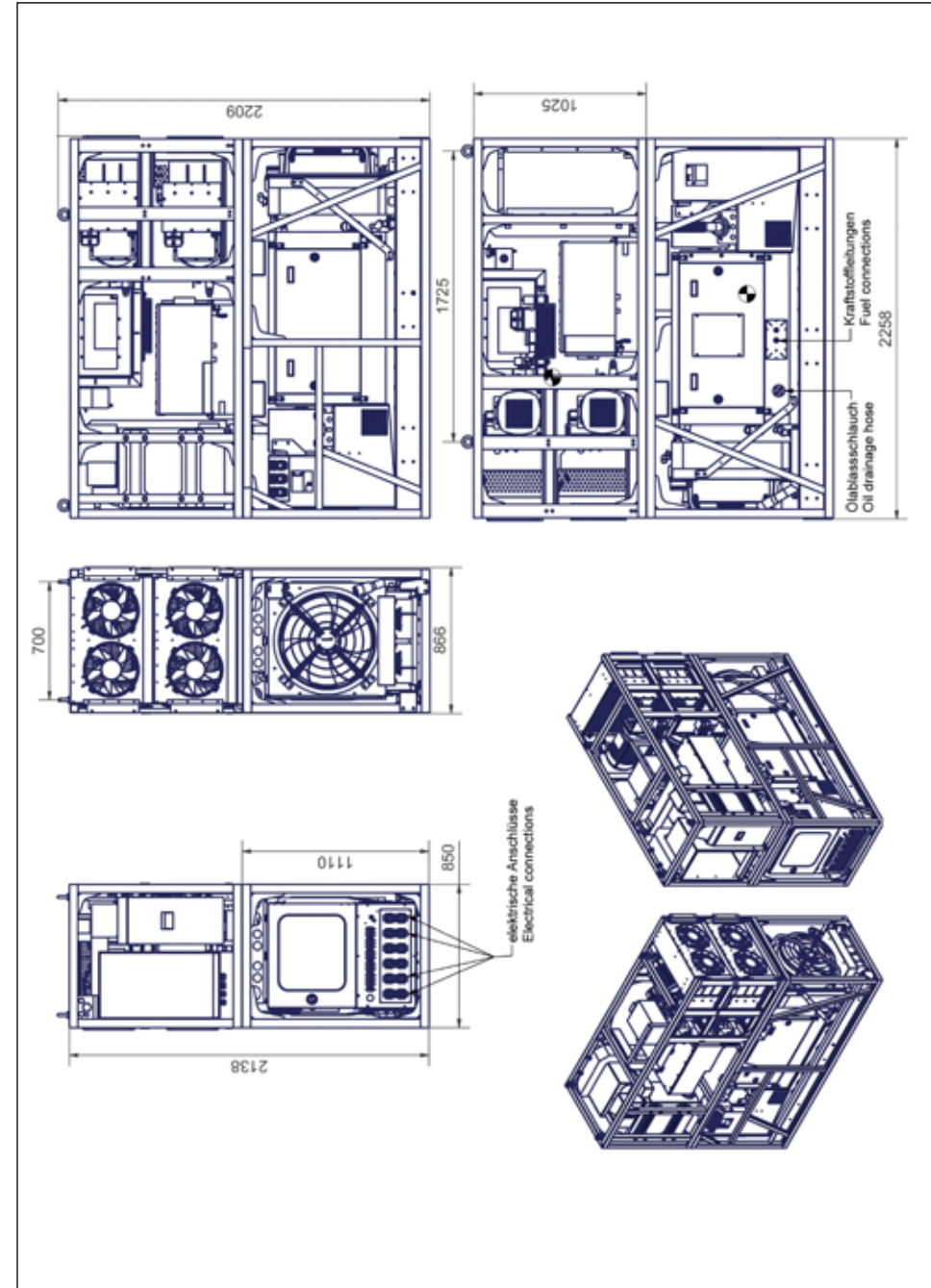

PANDA 60 CAPS



Generator	Panda 60 CAPS
	Combined generator + aircon + NBC filter+ heating # Built to comply with MIL STD 461E / MIL STD 810F # Ambient temperature - 46°C up to + 60°C
Constant Output	up to 60 kW elec. / 4 x 8kW cooling at 3000m / +50°C
Output Voltage	400 V 3-phase AC 50Hz
Output Current	3x86A
Start System	24V Electrical
Engine Manufacturer	Mercedes
Engine Type	OM602
Engine Cylinders	5
Engine Operating Temp. Range	
Fuel Types	F 34, F54, Standard automotive diesel fuel, kerosene, JP 8, JP 5, JET A
Approx. Fuel Consumption ¹⁾	5.8 - 19.8 l/h
Fuel Supply	Integrated Fuel Tank (470 litre capacity)
Frame / Mounting	Complete unit mounted in a frame
Cooling System	Integrated radiator and fans mounted for cooling
Instrumentation & Electrical	Integrated electrical cabinet
Approx APU weight (dry)	approx. 3500kg

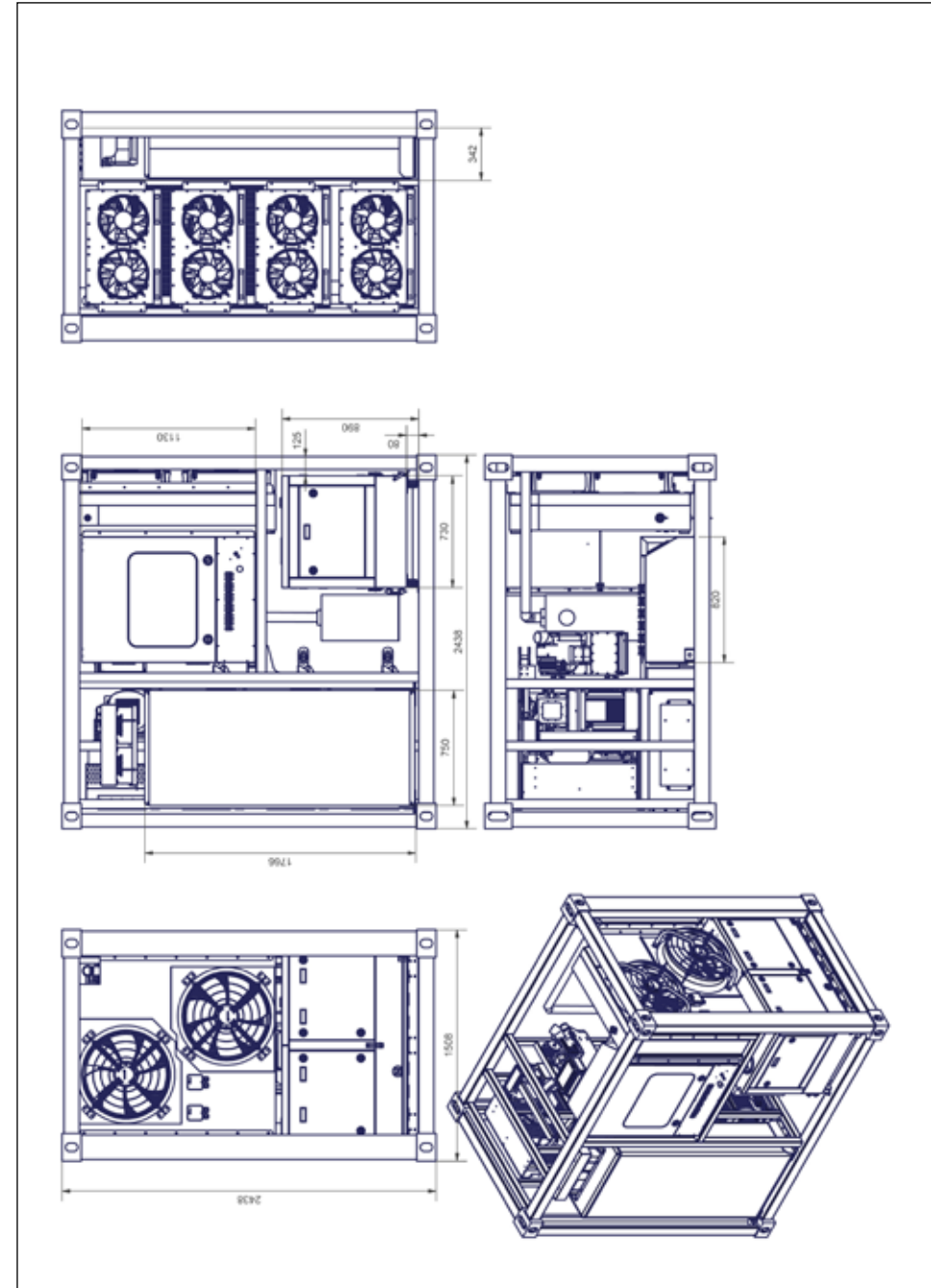

PANDA SST 25



Generator	Panda SST 25
	Water-cooled Generator with variable speed - constant frequency technology
Constant Output	25 kW at 3000m / +50°C
Output Voltage	120/208 V /60 Hz 3-phase
Output Current	3x86 A
Start System	24V Electrical
Engine Manufacturer	Kubota
Engine Type	V2403
Engine Cylinders	4
Engine Operating Temp. Range	-32°C up to +50°C (other temperature ranges on request)
Fuel Types	F 34, F 54 „Standard automotive diesel fuel, kerosene, JP 8, JP 5, JET A
Approx. Fuel Consumption ¹⁾	0.8 - 8.0 l/h
Fuel Supply	Connections for external or vehicle fuel tank
Frame / Mounting	Slide mounted on rails
Cooling System	Integrated radiator and fans for cooling
Instrumentation & Electrical	Integrated electrical cabinet with instruments and connections
Approx APU weight (dry)	705 kg

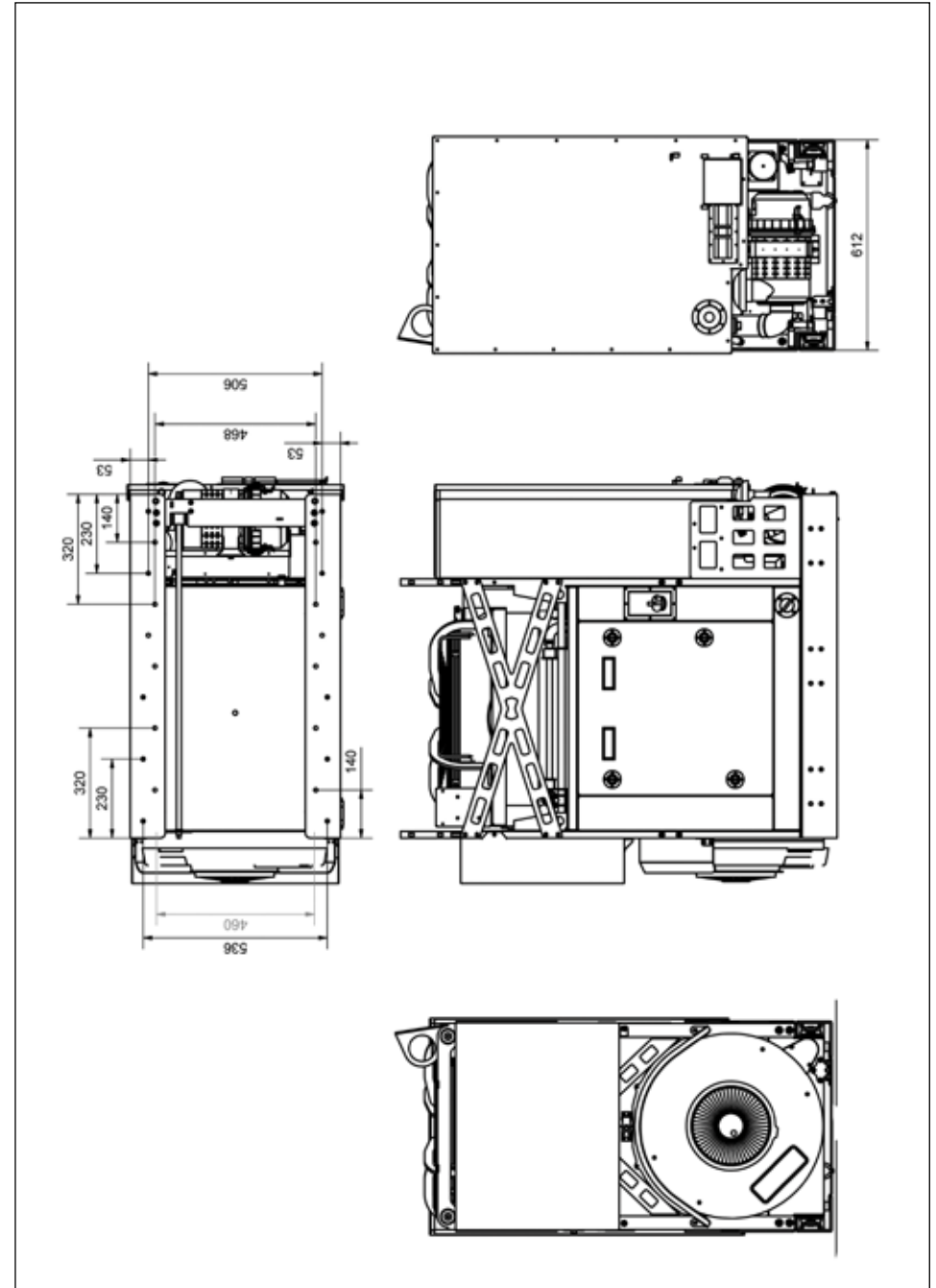

PANDA 6000 ECU



Cooling capacity	75,000BTU (6 Ton)
heating capacity	12 KW (40,960BTU / HR)
Voltage	3 x 208 Volts / 60 Hz or 3x400 Volts / 50Hz
Consumption	max. 15,5 kW
Refrigerant	R134A
Temperatures range	minus 8 deg to 52 deg C
operation	minus 32 deg to 52 deg C
storage	minus 40 geg to 60 deg C
Dimensions	1150 x 678 x 1215 mm
Weight (wet)	368.2 kg
NBC	NBC Ready

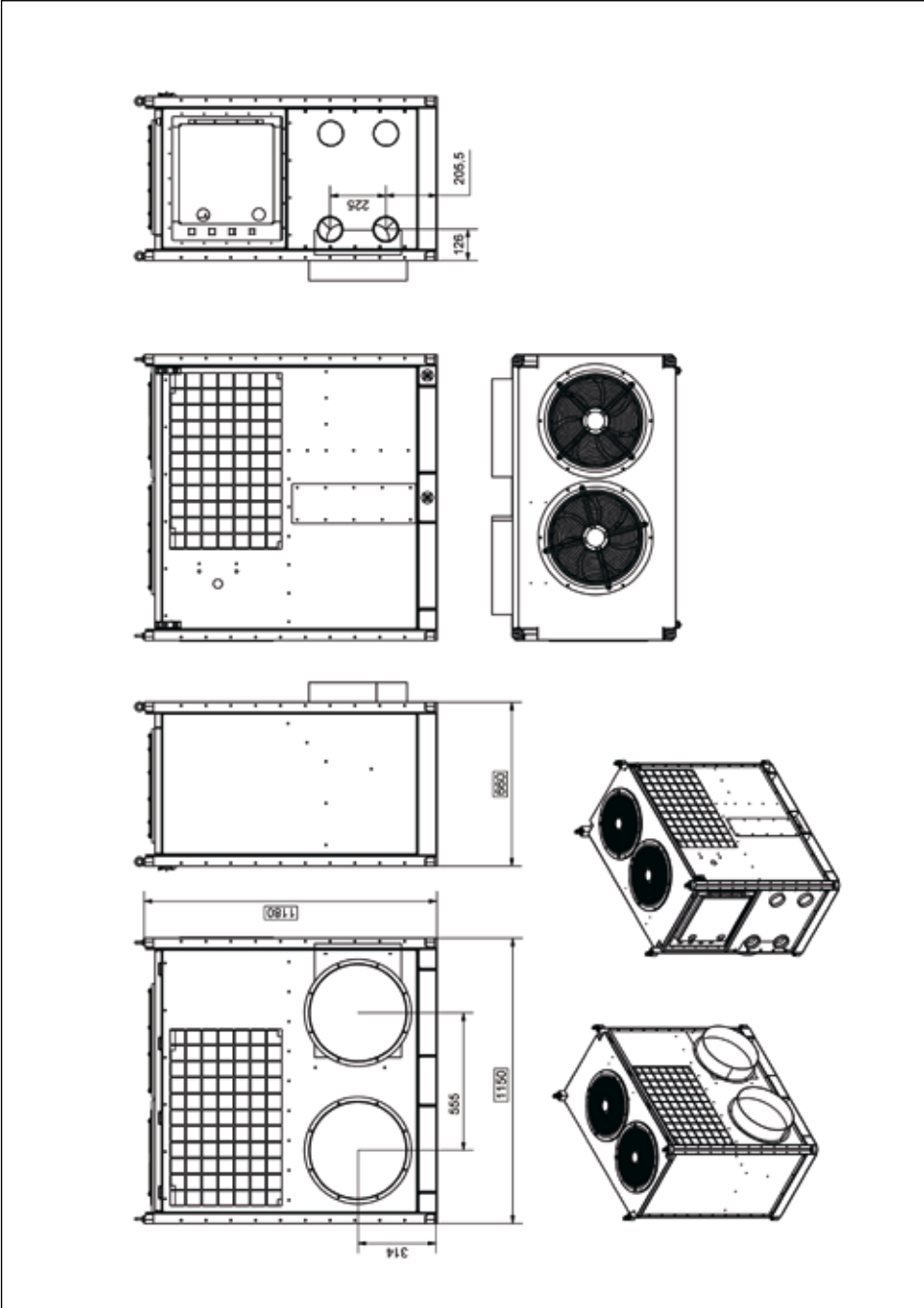

RTU-2 ECU

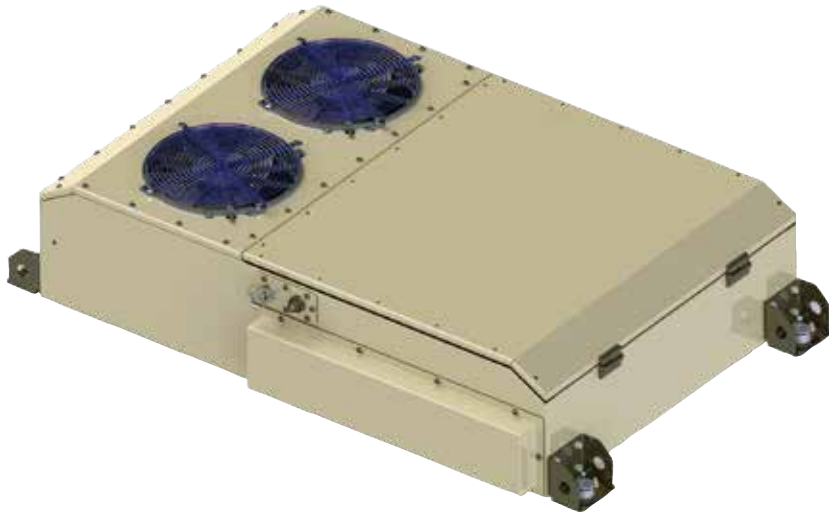

Technical Data:	
Cooling capacity:	R134a refrigerant
	@ 48VDC = 2.000 to 5.000 Watt, stepless regulated
	@ 250 – 400VDC = 4.000 to 8.000 Watt, stepless regulated
	@ 230 / 400VAC = 4.000 to 8.000 Watt, stepless regulated
	@ Hydraulic= 4.000 to 8.000 Watt, stepless regulated
Electric heating: (option)	5.000 Watt (17.000 BTU/h)@ 230-1 ph or 400-3ph VAG stepless regulated
Airflow evaporator:	up to 2.000m³/h, brushless ventilator motors, stepless regulated
	extremely low noise operation down to 39dB!
Airflow condenser:	up to 4.500m³/h - stepless regulated and pressure controlled {plc controller}
	2 brushless axialfans with low noise operation. Fail safe mode: operates also with 1 fan
Drive:	Electric compressors: variable power controlled with inverter over plc Controller
	Hydraulic compressors: variable power controlled over plc controller, 11 cm³ 3.000rpm motor
EMC:	meets MIL-STD 461E (only RTU-2 MIL version)
Shock Vibration:	meets MIL-STD810F (only RTU-2 MIL version)

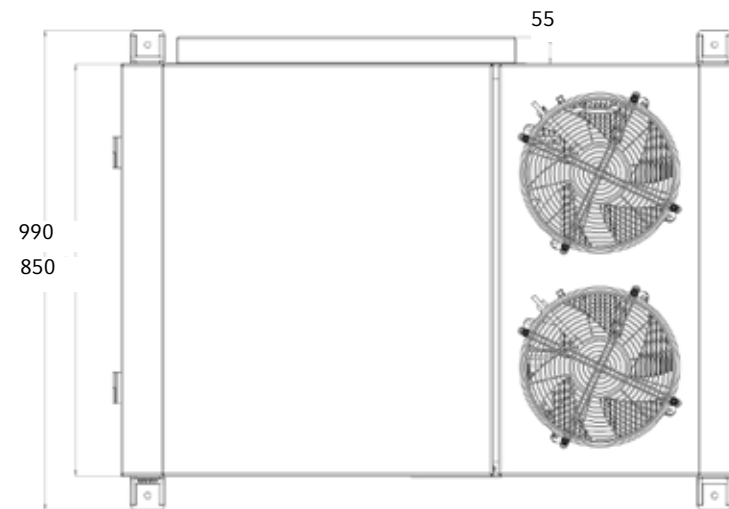
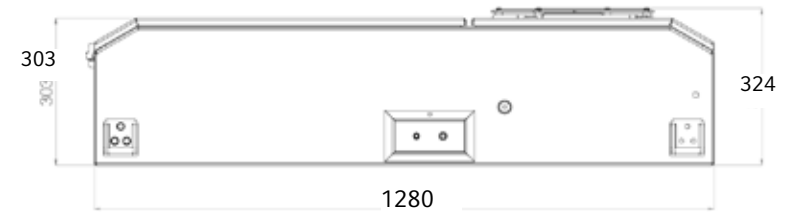



Communications



Mobile Workshops / Chassis Mounted Units



Command and Control Systems



Tracked Command Posts



AFV's



Recce



Trailer Mounted APUs



DROPS / PLS Based Applications



Tactical Shelters / Command Headquarters



Fischer Panda GmbH
Otto-Hahn-Str. 40
D-33104 Paderborn
Germany

Tel. : +49 (0)5254 9202-0
Fax : +49 (0)5254 9202-550
Email : defence@fischerpanda.de
Web : <http://www.fischerpanda-defence.de>

Disclaimer:

The information contained here is to the best of our knowledge accurate at the date of publication. Please note that the data in this publication reflects the technical state at time of print. Dimensions apply for the sound insulation capsule only and do not include latches, fittings etc. Additional room will need to be calculated for installation to include hoses, cables and capsule mountings. Additional components or alternators may also affect capsule dimensions. Due to our policy of continual product development, we reserve the right to alter technical specifications without notice. All performance data relates to air and water temperatures of 20°C. Performance reduction (approx. 1% per 100 m height and approx 2% per 5°C air temperature and approx. 1% per 1°C water temperature above 20°C)

Stand: 04-2014
Art.: 71.02.01 . H