



*Craftsman*  
MARINE

# CRAFTSMAN MARINE

CATALOGUE  
2015

A high-angle, forward-looking view from the deck of a white sailboat. The boat's deck is made of light-colored wood planking. A large blue sail is partially visible on the left, and another blue sail is hanging vertically from the mast. The boat is on a calm blue sea. In the background, there are green, hilly mountains under a bright blue sky with scattered white clouds.

# ABOUT CRAFTSMAN MARINE

*"We are highly motivated to provide you with smart solutions,  
so you can simply enjoy the water!"*



**Craftsman**  
MARINE

**Craftsman Marine is one of the leading companies in designing and engineering a wide variety of innovating products for pleasure craft and light commercial vessels. From our home base in The Netherlands we distribute our products throughout the entire globe, using an extensive network of certified dealerships and distributors.**

If you do not know Craftsman Marine, this catalogue is the best way to get a good glimpse of our product design and engineering skills. Here you'll find a complete overview of our marine product line and just like every year, you'll of course find some brand new items and products, all designed according to the high standards Craftsman Marine is known for.

So, without further ado, it is my distinct pleasure to present the fully updated Craftsman Marine Catalogue 2015. I would like to thank our entire team for their ambition and enthusiasm to compose this 2015 issue. And to all our customers: I look forward to continue working for you.

**Soerin Soekhoe**  
Director

*Craftsman Marine is based in Dordrecht - The Netherlands - and is part of Craftsman Automation, one of the largest industrial companies of India, specialised in designing and manufacturing world class products.*

# WORLD-WIDE DISTRIBUTION AND SERVICE

See our website for a dealer near you or contact the importer for your country.

## Australia

Stella Systems  
17 Rivergate Place, Unit 4  
MURARIE QLD 4172  
Tel. +61 7 3890 5680  
Fax. +61 7 3890 0374  
info@stellasystems.com.au  
www.stellasystems.com.au

## All Marine Spares

10a Wilmette Place  
Mona Vale 2103  
Tel. +61 2 9997 2788  
Fax. +61 2 9997 7611  
sales@allmar.com.au  
www.allmar.com.au

## Argentina

BARON S.A.  
Av. Libertador 1898  
San Fernando – Buenos Aires  
CP: 1646  
Argentina  
carolina.zamora@baronusa.net  
www.baron.com.ar

## Austria

ScanDiesel GmbH  
Ermlandstr. 59  
28777 Bremen  
Tel. +49 421 675 32-10  
Fax. +49 421 675 32-20  
Germany  
marine@scandiesel.de  
www.scandiesel.de

## Belgium

CM Benelux B.V.  
Baanhoek 152  
3361 GN Sliedrecht  
The Netherlands  
Tel. +31 184 499945  
Fax. +31 184 499925  
info@craftsmanmarinebenelux.com  
www.craftsmanmarinebenelux.com

## Chile

BARON S.A.  
Av. Libertador 1898  
San Fernando – Buenos Aires  
CP: 1646  
Argentina  
carolina.zamora@baronusa.net  
www.baron.com.ar

## Denmark

West Diesel AS  
H.E. Bluhmesvej 6  
DK-6700 Esbjerg  
Tel. +45 75 127044  
Fax. +45 75 452770  
westdiesel@westdiesel.dk  
www.westdiesel.dk

## Finland

Tapimer Oy  
Huhtimontie 2  
04200 Kerava  
Tel. +358 9 2746 530  
Fax. +358 9 27465315  
motor@tapimer.fi  
www.tapimer.fi

## France

DB Innovation  
26 allée de la Méditerranée  
34110 Frontignan, France  
Tel. +33 4 67 78 61 66  
Fax. +33 4 67 74 01 34  
contact@craftsman-marine.fr  
www.craftsman-marine.fr

## Germany

ScanDiesel GmbH  
Ermlandstr. 59  
28777 Bremen  
Tel. +49 421 675 32-10  
Fax. +49 421 675 32-20  
Germany  
marine@scandiesel.de  
www.scandiesel.de

## Greenland

West Diesel AS  
H.E. Bluhmesvej 6  
DK-6700 Esbjerg  
Denmark  
Tel. +45 75 127044  
Fax. +45 75 452770  
westdiesel@westdiesel.dk  
www.westdiesel.dk

## Iceland

Watermota Ltd  
Cavalier Road Heathfield Industrial  
Estate  
Newton Abbot  
Devon TQ12 6TQ  
United Kingdom  
Tel. +44 (0)1626 830910  
Fax. +44 (0)1626 830911  
info@watermota.co.uk  
www.watermota.co.uk

## Italy

Socoges  
Via Baione, Z.I.  
70043 Monopoli (BA)  
Italy  
Tel. +39 080 9373000  
Fax. +39 080 9371972  
e.galanto@socoges.it  
www.socoges.it

## Kaliningrad

Boatsman & C  
Kaliningrad, Russia  
St.Kolkhoznaya, 20  
236009  
Tel. 8 (4012) 584334  
M. +7 9114539616  
info@boatsman39.ru  
www.boatsman39.ru

## Liechtenstein

ScanDiesel GmbH  
Ermlandstr. 59  
28777 Bremen  
Tel. +49 421 675 32-10  
Fax. +49 421 675 32-20  
Germany  
marine@scandiesel.de  
www.scandiesel.de

## Luxembourg

CM Benelux B.V.  
Baanhoek 152  
3361 GN Sliedrecht  
The Netherlands  
Tel. +31 184 499945  
Fax. +31 184 499925  
info@craftsmanmarinebenelux.com  
www.craftsmanmarinebenelux.com

## Malaysia

Supreme Power Engineering  
No.4, Jalan Bulan U5/168,  
Seksyen U5, Sungai Buluh,  
40150 Shah Alam,  
Selangor Darul Ehsan  
Tel No. 603-78475064  
Fax No. 603-78475071  
cteckmeov@gmail.com

## Maldives

Seagull Group Pvt Ltd  
Narugis P.O.Box 2019 Chaandhanev  
Magu  
Malé 20191 Maldives  
Tel. +960 331 4933  
Fax. +960 332 5336  
info@seagullmaldives.com  
www.seagullmaldives.com

## Malta

Caruana Marine Centre  
Triq il-Ghadam 30  
Zejtun ZTN 2463  
Tel. +356 2182 1332  
+356 2099 2182  
M. +356 9942 6324  
info@caruanamarine.com  
www.caruanamarine.com

## Netherlands

CM Benelux B.V.  
Baanhoek 152  
3361 GN Sliedrecht  
Tel. +31 184 499945  
Fax. +31 184 499925  
info@craftsmanmarinebenelux.com  
www.craftsmanmarinebenelux.com





# Craftsman MARINE

## New Zealand

All Marine Spares  
10a Wilmette Place  
Mona Vale 2103  
Australia  
Tel. +61 2 9997 2788  
Fax. +61 2 9997 7611  
sales@allmar.com.au  
www.allmar.com.au

## Norway

Bildoy Marina  
DØsjØ  
5360 Kollveit  
Tel. +47 56 32 24 50  
Fax. +47 56 32 26 20  
post@bildoymarina.no  
www.bildoymarina.no

## Portugal

PASCH Y CIA. S.A.U.  
Paseo del Campo Volantín 24  
48007 Bilbao  
Spain  
Tel. +34 94 413 26 60  
Fax. +34 94 413 26 62  
infobilbao@pasch.es  
www.pasch.es

## Poland

Craftsman Marine Polska  
Sloneczna 5/22  
11-230 Bisztynek  
Tel. +48 089 761 23 24  
Fax. +48 89 761 23 24  
info@craftsmanmarine.pl  
www.craftsmanmarine.pl

## Romania

S.C. Watermota Romania S.R.L.  
Str. Unirii 114 Bl.U4 Apt. 50  
900526 Constanta  
Tel. +40 241 485 545  
Fax. +40 241 485 5546  
office@watermota.ro  
www.watermota.ro

## Russia

LLC "Dominator-Service"  
127322, Moscow,  
st. Milashenkova, h. NO 6 «A»  
Tel. +7 (499) 346-02-01  
Tel. +7 (925) 346-02-01  
sale@cmarine.ru  
www.cmarine.ru

## Slovenia

EXTREME d.o.o.  
PE Vizmarje, Plemljeva 8  
1210 Ljubljana  
Tel. +386 1 500 71 04  
Fax. +386 1 500 71 10  
M. +386 41 673 085  
hrovat@extreme-slo.com  
www.extreme-slo.com

## Singapore

Aqua International PTE LTD  
642 Rowell Road 02-115  
Singapore 200642  
Tel. +(65) 6299 1988  
Fax. +(65) 6299 1957  
Sales@aqua.sg  
www.aqua.sg

## Spain

PASCH Y CIA. S.A.U.  
Paseo del Campo Volantín 24  
48007 Bilbao  
Spain  
Tel. +34 94 413 26 60  
Fax. +34 94 413 26 62  
infobilbao@pasch.es  
www.pasch.es

## Sweden

Dintra AB  
1a Industrigatan 6  
681 30 Krintinehamn  
Tel. +46 550 81 900  
info@dintra.se  
www.marinmagasinet.se

## Switzerland

ScanDiesel GmbH  
Ermlandstr. 59  
28777 Bremen  
Tel. +49 421 675 32-10  
Fax. +49 421 675 32-20  
Germany  
marine@scandiesel.de  
www.scandiesel.de

## Thailand

Thai Kolon Co.Ltd.  
413 Moo 4, Soi Sitthichai  
Taiban Road, Tambol Taiban,  
Amphur Muang, Samutprakarn  
10280  
Thailand  
Tel. +66 (02) 7552710-15  
Fax. +66 (02) 7552716  
thaikolon@thaikolon.co.th  
www.thaikolon.co.th

## Turkey

Yüzer Marin  
Perpa Ticaret Merkezi B Blok  
Kat: 8 No: 915  
Okmeydanı / Istanbul  
Tel. +90 212 221 04 29  
+90 212 221 63 48  
Fax. +90 212 220 15 69  
info@yuzermarin.com  
www.yuzermarin.com

## Ukraine

Sevboatmotors  
Ostryakova 144/56  
99040 Sevastopol  
Tel. +380506863451  
Fax. +380692633023  
info@craftsmanmarine.com.ua  
www.craftsmanmarine.com.ua

## United Arab Emirates

Brook Marine Equipment Trading  
Company LLC.  
PO BOX 98189, DY 136 Al Jadaf  
Ship Docking Yard  
Dubai  
Tel. +971 4 3244848  
Fax. +971 4 3244845  
info@brookmarine.com  
www.brookmarine.com

## United States of America

AER Marine Supply  
4700 SW 51st Street  
Suite 212  
Davie, FL 33314  
Tel. +1 888.423.2664 Toll free  
Fax. +1 954.331.4532 Fax  
Sales@aersupply.com  
www.aersupply.com

## United Kingdom

Cheshire Marine Equipment  
Unit 2  
Aqueduct Marina  
The Outlanes  
Church Minshull Nantwich  
Cheshire CW5 6DX  
Tel. 01270 522000  
hello@cheshiremarine.co.uk  
www.cheshiremarine.co.uk

## Watermota Ltd.

Cavalier Road Heathfield  
Industrial Estate  
Newton Abbot  
Devon TQ12 6TQ  
Tel. +44 (0)1626 830910  
Fax. +44 (0)1626 830911  
info@watermota.co.uk  
www.watermota.co.uk



## Head office:

Craftsman Marine B.V.  
Pascalstraat 88  
3316 GR Dordrecht  
The Netherlands

Tel. +31 88 00 626 00  
Fax. +31 88 00 626 01

info@craftsmanmarine.com  
www.craftsmanmarine.com



# TABLE OF CONTENTS

## PROPULSION

Engines	10
Keel cooling	18
Flexible engine mounts	27
Spare parts	28
Saildrive & Foundation	30
Exhaust systems	34
Propeller shaft assemblies	36
Flexible couplings	39
Vector Drive	40
Engine remote controls	42
Strainers and water separators	45
Engine panels	46

## MANOEUVRING

Thrusters	50
Thruster selection	52
Electric thrusters	54
Thruster tubes	57
Stern thruster tunnel	57
Hydraulic thrusters	58
Thruster panels	64
Extension cables	67
Hydraulic thruster panels	67
Hydraulic steering systems	68

## STORAGE

Storage solutions	72
Tank covers	73
Storage tanks	74
Smell absorbers	75

## ELECTRONICS

Electronics	76
Wireless remote	79
Fuse and fuse holder	80
Battery switches	82
Batteries and cables	83
Cable and battery terminals	84
Gauges and accessories	88
Tank sensors	93

## DECK EQUIPMENT

Portholes & hatches	94
Anchor windlass	102
Anchor windlass controls	106
Anchor chain	107

## ACCESSORIES

Hoses & reducers	110
Valves and fittings	112

# THE PROPULSION OF YOUR BOAT

*"The Craftsman Marine inboard diesel engines are powerful, responsive, fuel efficient and power dense."*

Designing and engineering reliable, safe and smooth running marine engines is one of Craftsman Marine's core expertise. The shift in focus over the last decade, to create more energy efficient engines, has influenced our industry and subsequently our entire product range. All new marine diesel engines must meet increasingly stringent emission requirements. Our Mitsubishi and Hyundai based diesel engines totally comply with the latest iteration of the European Recreational Craft Directive (RCD).

At Craftsman Marine, we embrace all requirements concerning energy efficiency, emission- and noise level reduction and vibration- and friction control. It keeps us

up to speed with all the latest technologies and most of all, it keeps us on the front stage of marine engineering and forcing us to innovate continuously.

Craftsman Marine designs and supplies all propulsion components such as propellers, noise reducing exhaust systems, flexible couplings and entire propeller shaft assemblies. All these components match perfectly so that installing and refitting these products is relatively easy to accomplish.

All our diesel engines are fully tested according to the latest international requirements. Because we have extensive knowledge regarding the latest requirements

for robust diesel engine testing, you can be sure your engine will run smoothly and consistently.

We design every component with the future in mind. A Craftsman Marine Diesel engine is engineered according to the latest (tested and verified) technology. Of course, regular maintenance checks help your engine to last longer and to optimise performance and reliability.





## Diesel engines

Our two cylinder engine is built around a reliable Mitsubishi base that has earned its merits as a sturdy and reliable industrial engine. It has been converted into a fine marine diesel engine in accordance with the latest know how and technology. Craftsman Marine has selected these base engines on three principles: power, reliability and fuel efficiency. This engine is powerful for its small size and due to the compact build will fit even the smallest engine room. The CM2.16 engine is a well-balanced engine with vibration-free running and measures up to the latest European Recreational Craft Directive (RCD). It will also meet the upcoming new legislation that will be enforced from January 2016 (2013/53/EU).

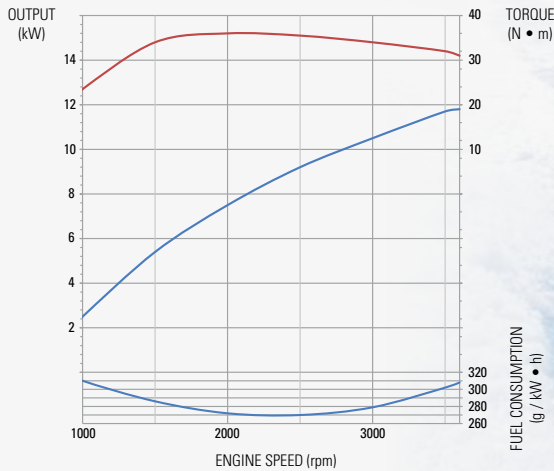

### Optional temperature sensor for cooling water

For a better insight in the temperature of the cooling water on your boat a temperature sensor and gauge can be added.

### Air inlet silencer

The inlet silencer is designed for optimal air flow to your engine, whilst minimising the noise coming back from your engine through the air intake. Made from durable synthetic material the air inlet silencer ensures a carefree and relaxed boating experience.

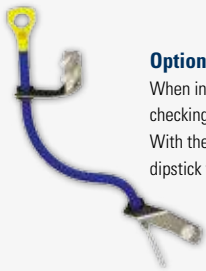

### Optional extended dipstick

When installing the engine in a small space, checking the oil level of your engine can be a pain. With the optional Craftsman Marine extended dipstick this becomes a thing of the past.

AR.200.90125



### General specifications

<b>Basic engine:</b>	Mitsubishi
<b>Output at flywheel:</b>	11.8kW/16HP (ISO 8665/3046)
<b>Maximum torque:</b>	36 Nm
<b>Number of cylinders:</b>	2
<b>Capacity:</b>	635 cm <sup>3</sup>
<b>Aspiration:</b>	natural
<b>Alternator:</b>	70 A / 12V Bosch
<b>Sensors:</b>	see page 23
<b>Max. installation angle:</b>	15° (backwards)
<b>Maximum revolutions:</b>	3600 rpm
<b>Cooling system:</b>	indirect, with heat exchanger
<b>Flexible engine mountings:</b>	CM type 2
<b>Calorifier connection:</b>	optional
<b>Exhaust diameter:</b>	ø40 mm
<b>Electronic protection:</b>	10A circuit breaker
<b>Stop solenoid:</b>	Energised to stop
<b>Weight:</b>	90 kg

### Optional:



ALFA 10E

AR.010.20000

See page 46 for the complete range of engine panels.

### Optional oil pressure sensor (instead of switch)

For a better insight in the oil pressure on your boat you can replace your oil pressure switch with an oil pressure sensor and gauge.



# CM2.16 11.8KW/16HP

ISO 8665/3046

**Assets:**

- Seawater resistant cast exhaust bend, providing a long and efficient service life
- Supplied with oil suction pump
- Based on a Mitsubishi industrial engine, proven world-wide and with an equally world-wide support

ALSO AVAILABLE AS KEELCOOL

**Cupronickel heat exchanger and exhaust bend - no zinc anode required**

This Copper-Nickel alloy has a better heat dissipation than steel or aluminium ensuring a better heat regulation for the engine. The heat exchanger also functions as an expansion tank for the cooling liquid of the engine. On top of that the material is highly resistant to corrosion in sea water, making the use of an anode unnecessary.



**Waterproof cable connectors**

The engine cable loom is equipped with waterproof (IP67) cable connectors to ensure that no moisture or dust can penetrate to the cable terminals.

Fitted with a 70A Bosch alternator

**Four flexible engine mountings**

See page 27 for the complete range of flexible engine mountings.

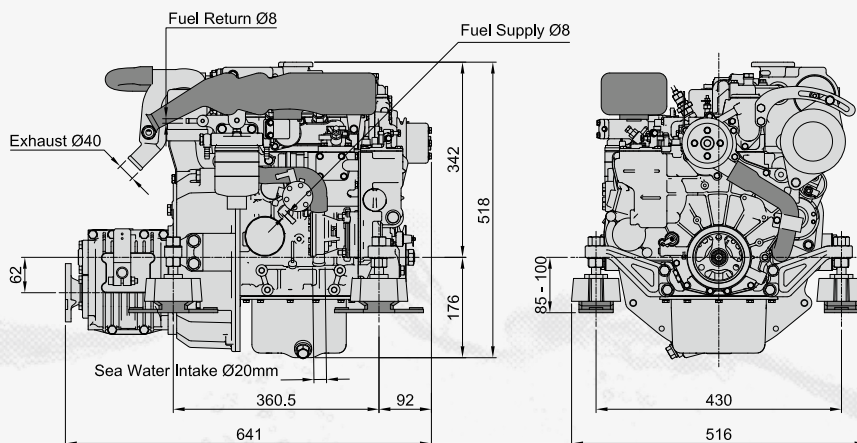

CALORIFIER KIT CM2.16 & CM3.27

AA.020.20000

**Optional remote oil filter**

Changing the oil filter can become difficult once the engine is fully installed in your boat. In order to accommodate an easier and faster oil filter replacement a Craftsman Marine remote oil filter kit was developed. The oil filter can be placed wherever you like. Standard hose length 1m.



AA.030.20000

For detailed specifications, drawings, manuals, certificates and warranty go to [www.craftsmanmarine.com](http://www.craftsmanmarine.com)

## Diesel engines

Our Mitsubishi based three cylinder engine is built around a robust and reliable industrial engine. It has been converted into a smart marine diesel engine in accordance with the latest know how and technology. Craftsman Marine has selected these base engines on three principles: power, reliability and fuel efficiency. The CM3.27 engine is a well-balanced engine with vibration-free running and measures up to the latest European Recreational Craft Directive (RCD). It will also meet the upcoming new legislation that will be enforced from January 2016 (2013/53/EU).

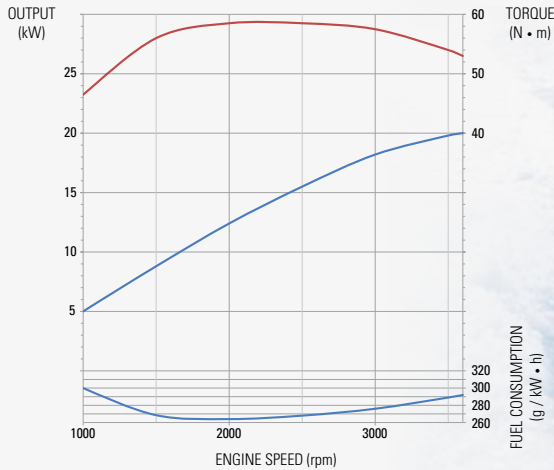

### Cupronickel heat exchanger and exhaust bend - no zinc anode required

This Copper-Nickel alloy has a better heat dissipation than steel or aluminium ensuring a better heat regulation for the engine. The heat exchanger also functions as an expansion tank for the cooling liquid of the engine. On top of that the material is highly resistant to corrosion in sea water, making the use of an anode unnecessary.

Exhaust temperature alarm

10A circuit breaker

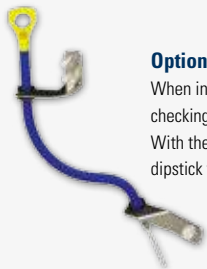

### Optional extended dipstick

When installing the engine in a small space, checking the oil level of your engine can be a pain. With the optional Craftsman Marine extended dipstick this becomes a thing of the past.

AA.300.90125

### General specifications

<b>Basic engine:</b>	Mitsubishi
<b>Output at flywheel:</b>	20kW/27.2HP (ISO 8665/3046)
<b>Maximum torque:</b>	58,5 Nm
<b>Number of cylinders:</b>	3
<b>Capacity:</b>	952 cm <sup>3</sup>
<b>Aspiration:</b>	natural
<b>Alternator:</b>	70 A / 12V Bosch
<b>Sensors:</b>	see page 23
<b>Max. installation angle:</b>	15° (backwards)*
<b>Maximum revolutions:</b>	3600 rpm
<b>Cooling system:</b>	indirect, with heat exchanger
<b>Flexible engine mountings:</b>	CM type 3 (front) & CM type 4 (back)*
<b>Calorifier connection:</b>	optional
<b>Exhaust diameter:</b>	ø40 mm
<b>Electronic protection:</b>	10A circuit breaker
<b>Stop solenoid:</b>	Energised to stop
<b>Weight:</b>	113 kg

### Optional:



ALFA 20E

AB.020.20000

See page 46 for the complete range of engine panels.

Waterproof connectors (IP67)

For detailed specifications, drawings, manuals, certificates and warranty go to [www.craftsmanmarine.com](http://www.craftsmanmarine.com)

\* 4 Flexible engine mounts CM type 9 are required for installation angles above 8°. Optional for extra comfort.



# CM3.27 20KW/27.2HP

ISO 8665/3046

Optional temperature sensor for cooling water



**Assets:**

- Seawater resistant cast exhaust bend, providing a long and efficient service life
- Fitted with a 70A Bosch alternator
- Supplied with oil suction pump
- Based on a Mitsubishi industrial engine, proven world-wide and with an equally world-wide support

ALSO AVAILABLE AS KEELCOOL

**Air inlet silencer**

The inlet silencer is designed for optimal air flow to your engine, whilst minimising the noise coming back from your engine through the air intake. Made from durable synthetic material the air inlet silencer ensures a carefree and relaxed boating experience.



All year long, use a good quality anti-freeze product, protecting your engine against corrosion and frost damage.



Always use good quality diesel fuel, free from water and/or other impurities.



**Four flexible engine mountings**

See page 27 for the complete range of flexible engine mountings.



**Manual stop button**

Additional mechanical engine stop button.

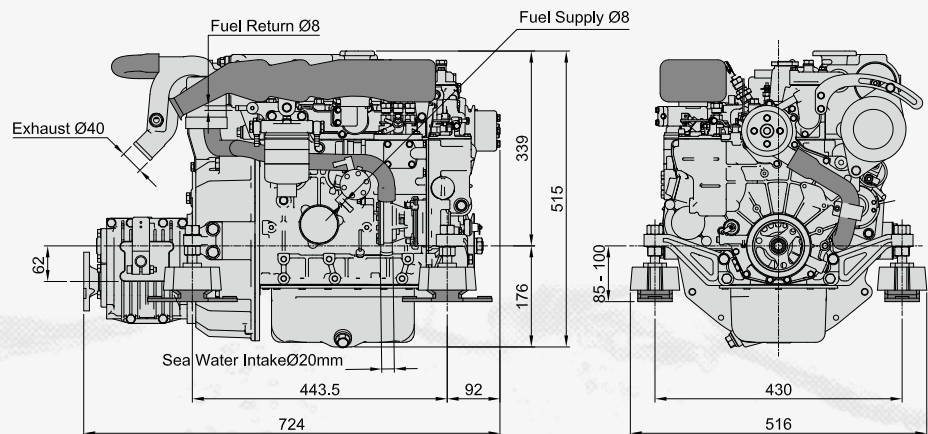

CALORIFIER KIT CM2.16 & CM3.27

AA.020.20000

**Optional remote oil filter**

Changing the oil filter can become difficult once the engine is fully installed in your boat. In order to accommodate an easier and faster oil filter replacement a Craftsman Marine remote oil filter kit was developed. The oil filter can be placed wherever you like. Standard hose length 1m.

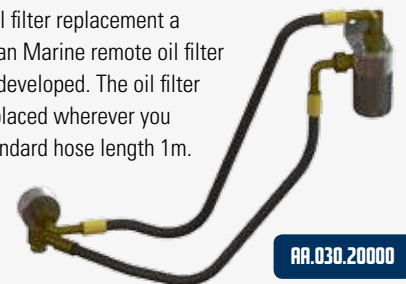

AA.030.20000

## Diesel engines

Our four cylinder engine is built around a reliable Mitsubishi base that has earned its merits as a sturdy and reliable industrial engine. It has been converted into a fine marine diesel engine in accordance with the latest know how and technology. Craftsman Marine has selected these base engines on three principles: power, reliability and fuel efficiency. This engine is known for its quiet and vibration-free running and measures up to the latest European Recreational Craft Directive (RCD). Even the new iteration (2013/53/EU) that will be enforced from January 2016 is no match for this Craftsman Marine engine.

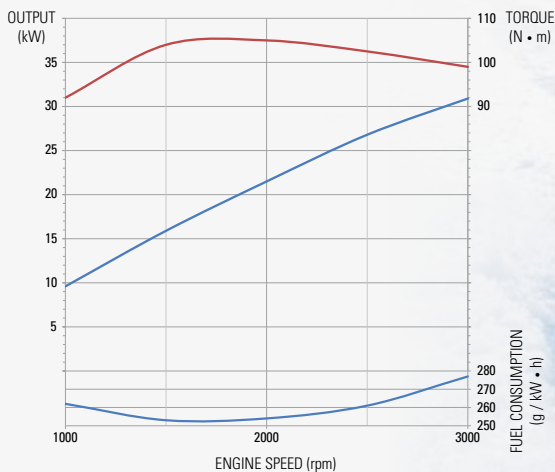

### Optional extended dipstick

When installing the engine in a small space, checking the oil level of your engine can be a pain. With the optional Craftsman Marine extended dipstick this becomes a thing of the past.

**RA.450.90125**

### Air inlet silencer

The inlet silencer is designed for optimal air flow to your engine, whilst minimising the noise coming back from your engine through the air intake. Made from durable synthetic material the air inlet silencer ensures a carefree and relaxed boating experience.

### Optional temperature sensor for cooling water

For a better insight in the temperature of the cooling water on your boat a temperature sensor and gauge can be added.



### General specifications

<b>Basic engine:</b>	Mitsubishi
<b>Output at flywheel:</b>	30.9kW/42HP (ISO 8665/3046)
<b>Maximum torque:</b>	105 Nm
<b>Number of cylinders:</b>	4
<b>Capacity:</b>	1758 cm <sup>3</sup>
<b>Aspiration:</b>	natural
<b>Alternator:</b>	90 A / 12V Bosch
<b>Sensors:</b>	see page 23
<b>Max. installation angle:</b>	15° (backwards)
<b>Maximum revolutions:</b>	3000 rpm
<b>Cooling system:</b>	indirect, with heat exchanger
<b>Flexible engine mountings:</b>	CM type 5*
<b>Calorifier connection:</b>	optional
<b>Exhaust diameter:</b>	ø50 mm
<b>Electronic protection:</b>	10A circuit breaker
<b>Stop solenoid:</b>	Energised to stop
<b>Weight:</b>	175 kg

### Optional:



**ALFA 20E**

**AB.020.20001**

See page 46 for the complete range of engine panels.

For detailed specifications, drawings, manuals, certificates and warranty go to [www.craftsmanmarine.com](http://www.craftsmanmarine.com)

\* 4 Flexible engine mounts CM type 9 are required for installation angles above 8°. Optional for extra comfort.



# CM4.42 30.9KW/42HP

ISO 8665/3046

**Assets:**

- Seawater resistant cast exhaust bend, providing a long and efficient service life
- Supplied with oil suction pump
- Fitted with electric fuel lift pump
- Based on a Mitsubishi industrial engine, proven world-wide and with an equally world-wide support

**ALSO AVAILABLE AS KEELCOOL**

**Cupronickel heat exchanger and exhaust bend - no zinc anode required**

This Copper-Nickel alloy has a better heat dissipation than steel or aluminium ensuring a better heat regulation for the engine. The heat exchanger also functions as an expansion tank for the cooling liquid of the engine. On top of that the material is highly resistant to corrosion in sea water, making the use of an anode unnecessary.



Always use good quality diesel fuel, free from water and/or other impurities.

Fitted with a 90A Bosch alternator

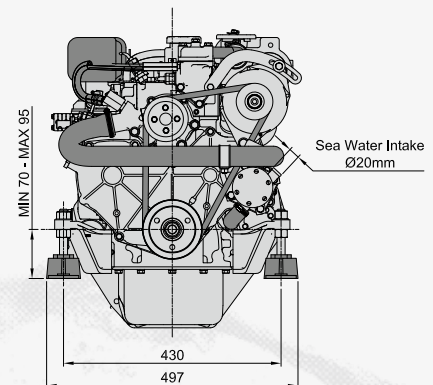
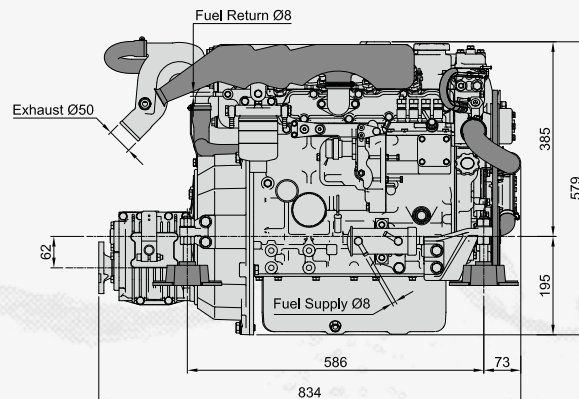

When a hydraulic gearbox is fitted to the engine, an additional oil cooler set is essential. This kit includes all necessary hoses and brackets to connect the oil cooler.

**OILCOOLER SET CM4.42**

**AA.010.20010**

**CALORIFIER KIT CM4.42**

**AA.020.20010**

**Optional remote oil filter**

Changing the oil filter can become difficult once the engine is fully installed in your boat. In order to accommodate an easier and faster oil filter replacement a Craftsman Marine remote oil filter kit was developed. The oil filter can be placed wherever you like. Standard hose length 1m.

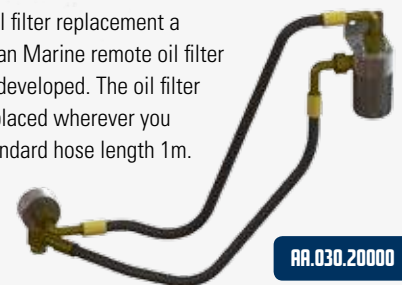

**AA.030.20000**

## Diesel engines

Our Hyundai based engines have been converted into fine marine diesel engines in accordance with the latest know how and technology. Craftsman Marine has selected these base engines on three principles: power, reliability and fuel efficiency. On top of that, these engines are known for their quiet and vibration-free running, and of course they measure up to the latest European Recreational Craft Directive (RCD).

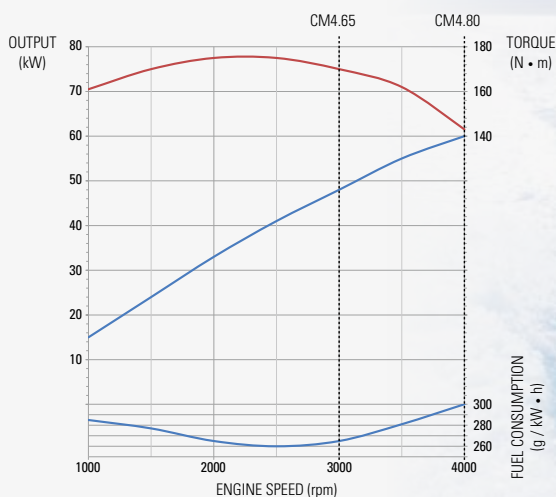

### Standard fitted long dipstick

For easy inspection of the oil level of your engine.

### Standard fitted with dual station throttle kit

For connecting a dual station control (see page 43).

### Fuel filter

Easy accessible fuel filter for quick inspection and easy replacement.

### 10A circuit breaker

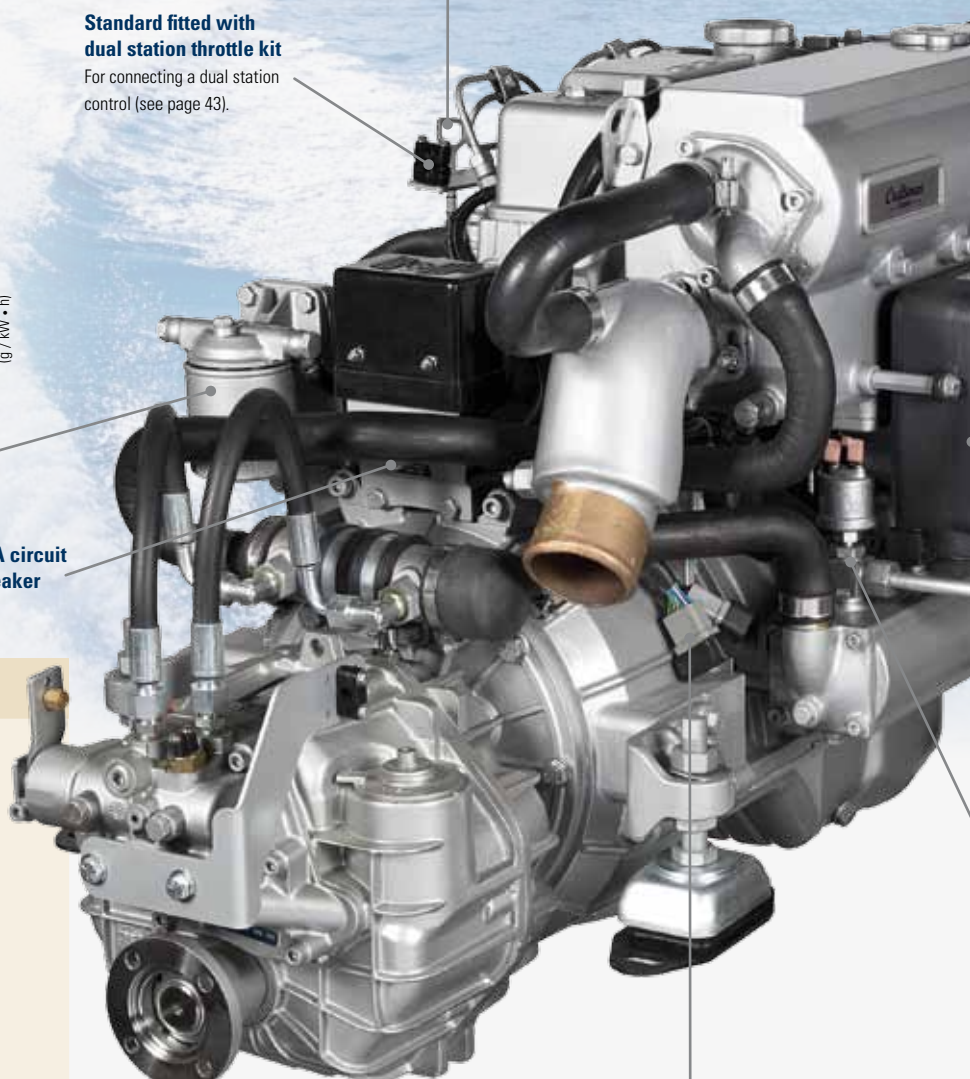

### General specifications

<b>Basic engine:</b>	Hyundai
<b>Output at flywheel:</b>	48kW/65HP (ISO 8665/3046) 59kW/80HP (ISO 8665/3046)
<b>Maximum torque:</b>	175 Nm
<b>Number of cylinders:</b>	4
<b>Capacity:</b>	2607 cm <sup>3</sup>
<b>Aspiration:</b>	natural
<b>Alternator:</b>	110 A / 12V Bosch
<b>Sensors:</b>	see page 23
<b>Max. installation angle:</b>	10° (backwards)
<b>Maximum revolutions:</b>	3000 rpm (CM4.65) 4000 rpm (CM4.80)
<b>Cooling system:</b>	indirect, with heat exchanger
<b>Flexible engine mountings:</b>	CM type 7
<b>Calorifier connection:</b>	standard
<b>Exhaust diameter:</b>	ø60 mm (CM4.65) ø76 mm (CM4.80)
<b>Electronic protection:</b>	10A circuit breaker
<b>Stop solenoid:</b>	Energised to run
<b>Weight:</b>	235 kg

### Optional:



ALFA 30E

AB.030.20000

See page 46 for the complete range of engine panels.

### Waterproof connectors (IP67)

For detailed specifications, drawings, manuals, certificates and warranty go to [www.craftsmanmarine.com](http://www.craftsmanmarine.com)

\* 4 Flexible engine mounts CM type 9 are required for installation angles above 8°. Optional for extra comfort.



**CM4.65** 48KW/65HP  
 ISO 8665/3046  
**CM4.80** 59KW/80HP  
 ISO 8665/3046



**Assets:**

- Quiet running with less vibrations due to a specially designed flywheel
- Seawater resistant cast exhaust bend, providing a long and efficient service life
- Supplied with oil suction pump
- Fitted with electric fuel lift pump
- Based on a Hyundai industrial engine, proven world-wide and with an equally world-wide support
- Air intake with noise reducing properties

**Cupronickel heat exchanger and exhaust bend - no zinc anode required**

This Copper-Nickel alloy has a better heat dissipation than steel or aluminium ensuring a better heat regulation for the engine. The heat exchanger also functions as an expansion tank for the cooling liquid of the engine. On top of that the material is highly resistant to corrosion in sea water, making the use of an anode unnecessary.



Check the wet exhaust on your transom for the proper flow of cooling water each time you start the engine to make sure enough water runs through the engines system.

**Fitted with a 110A Bosch alternator**

**Air inlet silencer**

The inlet silencer is designed for optimal air flow to your engine, whilst minimising the noise coming back from your engine through the air intake. Made from durable synthetic material the air inlet silencer ensures a carefree and relaxed boating experience.

**Fitted with oil and temperature sensor**

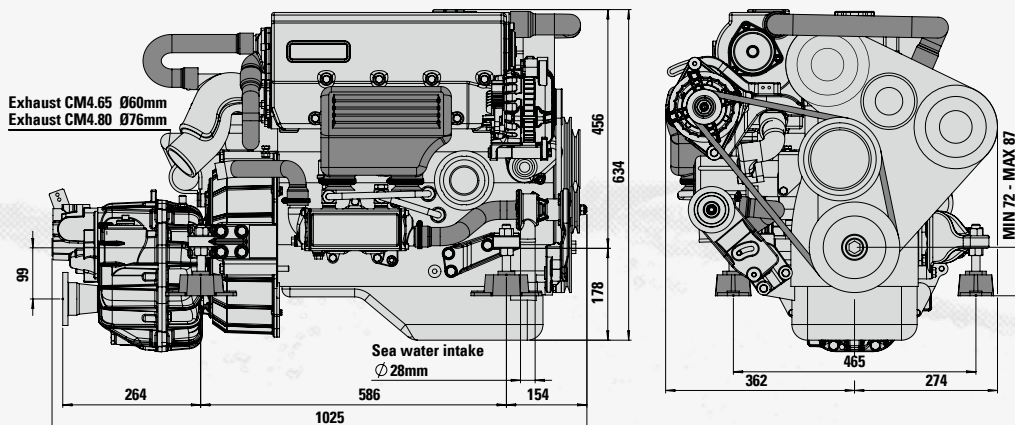

When a hydraulic gearbox is fitted to the engine, an additional oil cooler set is essential. This kit includes all necessary hoses and brackets to connect the oil cooler.

**OILCOOLER SET CM4.65/CM4.80**

**RA.010.20020**



## Keel cooling

The Craftsman Marine Mitsubishi based diesel engines can also be fitted with keel cooling. This can be very beneficial for sailing through shallow or muddy waters or for shallow draft boats sailing through waters with limited depth. Due to unparalleled quality and superior service backed by decades of experience, these keel cooling engines are the perfect solution for smooth sailing through waters where mud, sand or debris can potentially damage and clog up a conventional water cooled system.

Our keel cooled engines are engineered using the latest cooling technology. Simply put, there is no need for a raw water pump, so eliminates one more service point from your engine. These engines reduce maintenance costs and minimise downtime. Using keel cooling, only the cooling liquid will be pumped through the engine and the keel cooler element by the engine water pump. As a consequence, a keel cooling engine requires a heat resistant exhaust system.

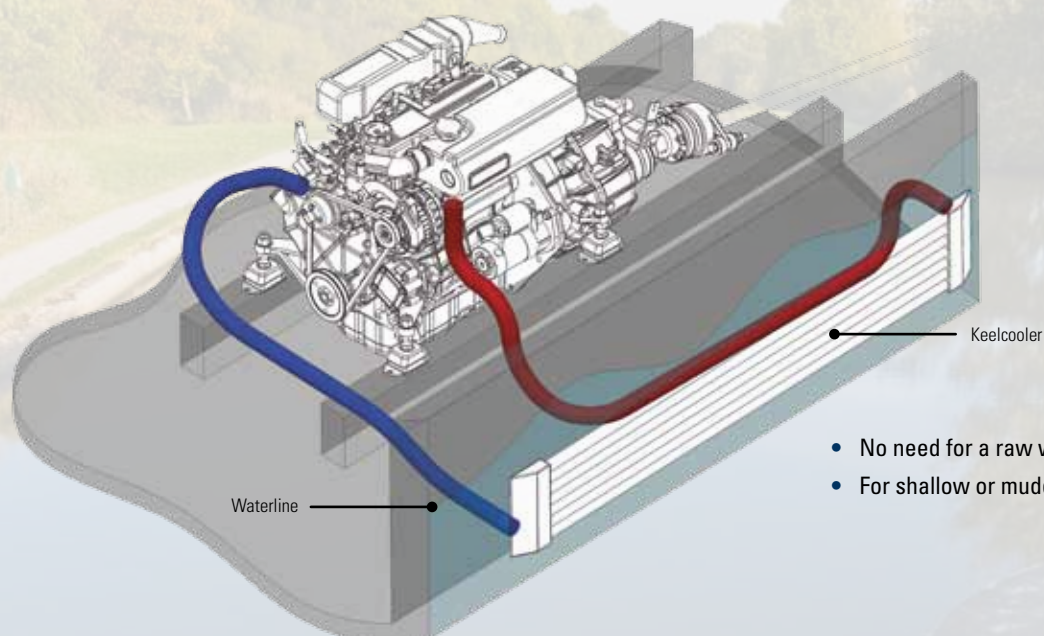

*These engines can be supplied with the same gearboxes as the intercooled engines. For engine specifications please check out the intercooled versions on the previous pages.*



**WHATEVER WATERWAY YOU'RE  
TRAVELLING, YOU CAN ALWAYS  
TRUST A CRAFTSMAN MARINE  
DIESEL ENGINE!**



## Selection chart of available engine and gearbox combinations

Craftsman Marine engines can be fitted with a selection of ZF/PRM gearboxes or Saildrives. Below are the possible combinations with our engines to suit your need. When in doubt, consult your dealer to determine which reduction will suit your boat and propeller. For the hydraulic gearboxes a separate oil cooler set is available.



	CM2.16	CM3.27	CM4.42	CM4.65/CM4.80
ZF10M	R=2,05	R=2,05	R=2,05	-
PRM80	R=2,50	R=2,50	-	-
ZF12M	R=2,14 R=2,63	R=2,14 R=2,63	R=2,14 R=2,63	-
ZF15M	-	-	R=1,88	-
ZF15MA	-	-	R=2,14 R=2,63	-
ZF25	-	-	R=1,97 * R=2,80 *	R=1,97 R=2,80
ZF25A	-	-	R=1,93 * R=2,71 *	R=1,93 R=2,71
ZF25M	-	-	R=1,88 * R=2,74 *	R=1,88 R=2,74
Saildrive SD10	R=2,23	R=2,23	R=2,23	-
Saildrive SD12	-	-	-	R=2,49

\* Please check the engine configuration chart on our website to fit a ZF25 gearbox to our CM4.42 engine. Other gearboxes are available on request.

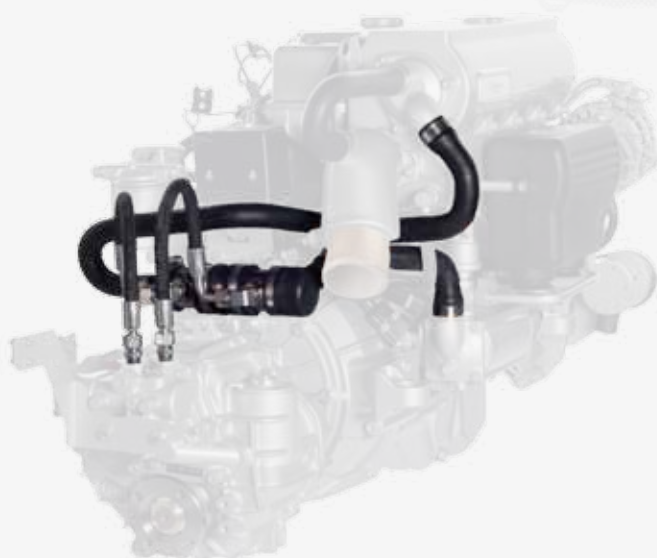

When a hydraulic gearbox is fitted to the engine, an additional oil cooler set is essential. This kit includes all necessary hoses and brackets to connect the oil cooler.

OILCOOLER SET CM4.42

AA.010.20010

OILCOOLER SET CM4.65/CM4.80

AA.010.20020

## Selection chart for choosing your engine panel and sensors

Craftsman Marine offers a wide range of engine panels. See page 46 for details about the engine panels. The engines are fitted with several sensors, which match a panel as described below. When choosing a different panel, ensure that you upgrade the engine with the correct sensors.

When installing a fly-bridge panel ensure that you have the right connection cables and interface cards, see page 24.

				
	<b>CM2.16</b>	<b>CM3.27</b>	<b>CM4.42</b>	<b>CM4.65/CM4.80</b>
<b>Cables supplied with engine</b>	2m, Type A 2m, Type B	4m, Type A 4m, Type B	4m, Type A 4m, Type B	4m, Type A 4m, Type B
<b>Engine fitted with sensors for</b>				
Exhaust temperature alarm	✓	✓	✓	✓
Oil pressure alarm	✓	✓	✓	✓
Oil pressure gauge	-	-	-	✓
Coolant temperature alarm	✓	✓	✓	✓
Coolant temperature gauge	-	-	-	✓
<b>Required sensors</b>				
<b>ALFA10</b> 	No extra sensor required	No extra sensor required	No extra sensor required	No extra sensor required
<b>ALFA20</b> 	No extra sensor required	No extra sensor required	No extra sensor required	No extra sensor required
<b>ALFA20</b> (voltmeter replaced with temperature gauge)	Temperature sensor/switch DB.020.20002 	Temperature sensor/switch DB.020.20002	Temperature sensor DB.020.20003 	No extra sensor required
<b>ALFA30</b> 	Temperature sensor/switch DB.020.20002 Oil pressure sensor/switch DB.020.20001 	Temperature sensor/switch DB.020.20002 Oil pressure sensor/switch DB.020.20001	Temperature sensor DB.020.20003 Oil pressure sensor/switch DB.020.20001	No extra sensor required
<b>ALFA40</b> 	Temperature sensor/switch DB.020.20002 Oil pressure sensor/switch DB.020.20001	Temperature sensor/switch DB.020.20002 Oil pressure sensor/switch DB.020.20001	Temperature sensor DB.020.20003 Oil pressure sensor/switch DB.020.20001	No extra sensor required

## Selection Chart for Fly-bridge panels

To connect a fly-bridge engine panel, the following connection parts are required.

Fly-bridge combinations	Required parts			Configuration
	Splitter cables		Fly-bridge connection card	
	Type A AB.050.20000	Type B AB.050.21000	Code AB.060.20000	
<b>ALFA10 + ALFA10</b>	✓	✓	-	1
<b>ALFA10 + ALFA20</b>	✓	✓	-	1
<b>ALFA10 + ALFA20</b> (ALFA20 voltmeter replaced by temperature gauge)	✓	✓	-	1
<b>ALFA10 + ALFA30</b>	✓	✓	-	1
<b>ALFA10 + ALFA40</b>	✓	✓	-	1
<b>ALFA20 + ALFA30</b>	✓	✓	-	1
<b>ALFA20 + ALFA30</b> (ALFA20 voltmeter replaced by temperature gauge)	✓	-	✓	2
<b>ALFA20 + ALFA40</b>	✓	✓	-	1
<b>ALFA20 + ALFA40</b> (ALFA20 voltmeter replaced by temperature gauge)	✓	-	✓	2
<b>ALFA30 + ALFA30</b>	✓	-	✓	2
<b>ALFA30 + ALFA40</b>	✓	-	✓	2
<b>ALFA40 + ALFA40</b>	✓	-	✓	2



Fly-bridge connection card

### Fly-bridge configuration 1

For this configuration the connection card is not required.



### Fly-bridge configuration 2

For this configuration the connection card is required.

*Panel fitted with fly-bridge connection card*

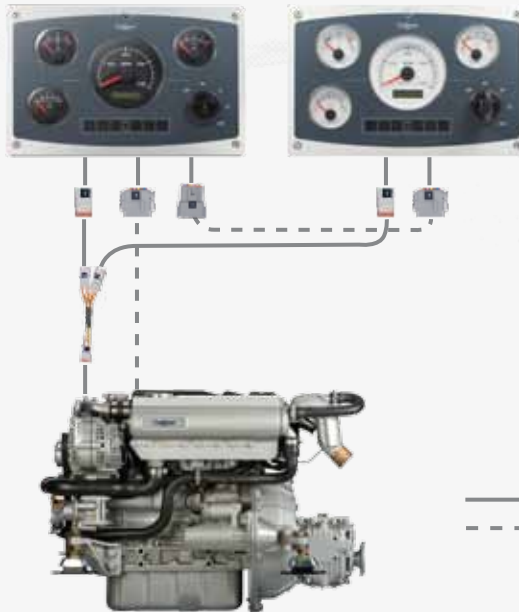

— Cable type A (power)  
- - - Cable type B (signals)



## Engine connection cables

To connect the Craftsman Marine engine with a Craftsman Marine engine panel, 2 cables are required. Cable type A is for power and cable type B is for signals. The cables are available in lengths of 2m, 4m, 6m and 10m. It is possible to connect different cable lengths together.

To protect the electrical installation against moisture, salt, water, dust or dirt, all cables are fitted with waterproof connectors. Each engine is standard supplied with cable A and B, with lengths of 4 metre each (CM2 with 2 metre).



- Waterproof connectors IP67 rubber sealing
- Latch lever lock, to ensure a 100% tight connection, also in case of vibrations



Article codes			
<b>AB.050.20002</b>	Connection cable engine panel 2m, type A	<b>AB.050.21002</b>	Connection cable engine panel 2m, type B
<b>AB.050.20004</b>	Connection cable engine panel 4m, type A	<b>AB.050.21004</b>	Connection cable engine panel 4m, type B
<b>AB.050.20006</b>	Connection cable engine panel 6m, type A	<b>AB.050.21006</b>	Connection cable engine panel 6m, type B
<b>AB.050.20010</b>	Connection cable engine panel 10m, type A	<b>AB.050.21010</b>	Connection cable engine panel 10m, type B



**SPLITTER CABLE TYPE A**    **AB.050.20000**



**SPLITTER CABLE TYPE B**    **AB.050.21000**



Photo by Goos Watersport (The Netherlands)  
Boat: Grou 288 Tender  
Engine: CM4.42

## Flexible engine mounts

Craftsman Marine flexible engine mounts absorb engine vibrations. The new CM type 9 and 10 are extra flexible to absorb more vibrations in light boats otherwise transferred to hull. Especially when used in combination with our new Vector Drive (see page 40).

Type		Article code	Stud	Hole spacing	Max. load	Stiffness
CM type 2		AA.200.90018	M16 fine	100 mm	45 kg	45 shore
CM type 3		AA.300.90018	M16 fine	100 mm	35 kg	45 shore
CM type 4		AA.300.90019	M16 fine	100 mm	45 kg	55 shore
CM type 5		AA.400.90018	M16 fine	100 mm	50 kg	50 shore
CM type 6		AA.400.90019	M16 fine	100 mm	75 kg	60 shore
CM type 7		AA.480.90018	M18 fine	138 mm	100 kg	45 shore
CM type 8		AA.480.90017	M18 fine	138 mm	150 kg	55 shore
CM type 9		AA.300.90017	M16 fine	174 mm	40 kg	40 shore
CM type 10		AA.400.90017	M16 fine	174 mm	70 kg	50 shore



# CRAFTSMAN MARINE SPARE PARTS

## **The Craftsman Marine special service kit, for the most essential spare parts.**

Our dealers are glad to assist you in selecting the parts you require. They will be pleased to carry out any specialist fittings you might need.

Our dealers will also make sure that all service jobs will be neatly recorded in your maintenance and service manual which you have received together with your Craftsman Marine engine.

This way you will have a clear and accurate recording of all maintenance jobs that have been done on your engine.

We have collected the most essential spare parts for you in a special service kit. Here you will find an oil- and fuel filter, a V-belt and an impeller.

### **MAINTENANCE TIP:**

We recommend that you, as a boat owner, will store at least this kit on board, as well as the required tools for replacement fitting.



SERVICE KIT CM2.16 & CM3.27

AA.200.90054

SERVICE KIT CM4.42

AA.400.90006

SERVICE KIT CM4.65 & CM4.80

AA.480.90010

# SAILDRIVE FOR YOUR ENGINE

*A Craftsman Marine saildrive is a thoroughly reliable means of propulsion, designed for easy control and minimal service.*



**MAINTENANCE TIP:**  
Do not use copper containing anti-fouling to protect the saildrive, correct any scratches on the protective coating and replace the anode when it has dissolved for more than 50%.



SAILDRIVE SD10

AJ.010.21022

SAILDRIVE SD12

AJ.010.22025

## The assets and advantages of a Craftsman Marine saildrive:

- Dual sealing diaphragm with water indicator for maximum security
- Forward and backward installation are both possible
- Easy and simple installation, as well as very few vibrations, compared with a conventional shaft assembly
- A completely dry system. No water lubricated shaft.
- High efficiency, on account of the thrust power running parallel with the propulsion direction
- Water inlet positioned at a low level prevents pollution of the cooling system
- No alignment whatsoever required
- Suitable for twin engine installations

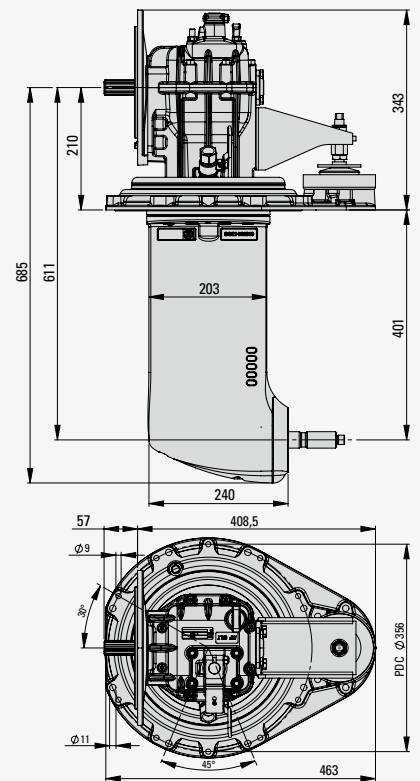

	SD10	SD12
<b>Gear ratio:</b>	2,23:1	2,49:1
<b>Weight:</b>	40 kg	40 kg
<b>Input power capacity:</b>	67hp (@3200rpm) - 75hp (@3600rpm)	82hp (@3200rpm) - 92hp (@3600rpm)

## More and more yacht builders install a saildrive

Contrary to a conventional shaft assembly, a saildrive does not require any alignment to ensure good efficiency and less vibrations. The fact that the thrust power is in the same sphere as the direction of the boat ensures an efficient propulsion mode.

A saildrive is utterly reliable, requires very little maintenance and can be equipped with a large selection of fixed or folding propellers. Contrary to older sail drive models, the Craftsman Marine saildrive features a dual sealing diaphragm, ensuring that the risk of leakage is reduced to an absolute minimum. Should the outside diaphragm become damaged for some

reason, the inside diaphragm will keep the boat completely dry. A water indicator provides an early warning against a possible leakage, in a convenient manner.

Because of the low positioning of the cooling water openings, mostly clean water will be taken in. Even so, also with this saildrive the use of a Craftsman Marine water strainer (AG.010.20019) is recommended. The water flow is then easily visible and the risk of clogging in the cooling water circuit is avoided.

By installing a saildrive, positioning of the engine becomes much more flexible. When required, the engine can be installed behind the saildrive to make optimum use of the space available.

In the case of e.g. a catamaran, the saildrive can also be supplied with a reversed reduction gear, so that a left-handed and a right-handed propeller can be fitted.

In order to facilitate the installation in an optimal way, Craftsman Marine offers a special universal foundation to be bonded into the boat.





*Photo by Goos Watersport (The Netherlands)  
Boat: Espevaer 22-open  
Engine: CM3.27*

**MISTY WATERS OR CLEAR SKIES, YOU CAN  
ALWAYS RELY ON OUR PRODUCTS TO GET  
YOU WHERE YOU WANT TO GO!**



# CRAFTSMAN MARINE SOUNDLOCK

*Craftsman Marine has developed a totally new concept for its exhaust assemblies, resulting in an optimal noise reduction and a drastically reduced installation time.*

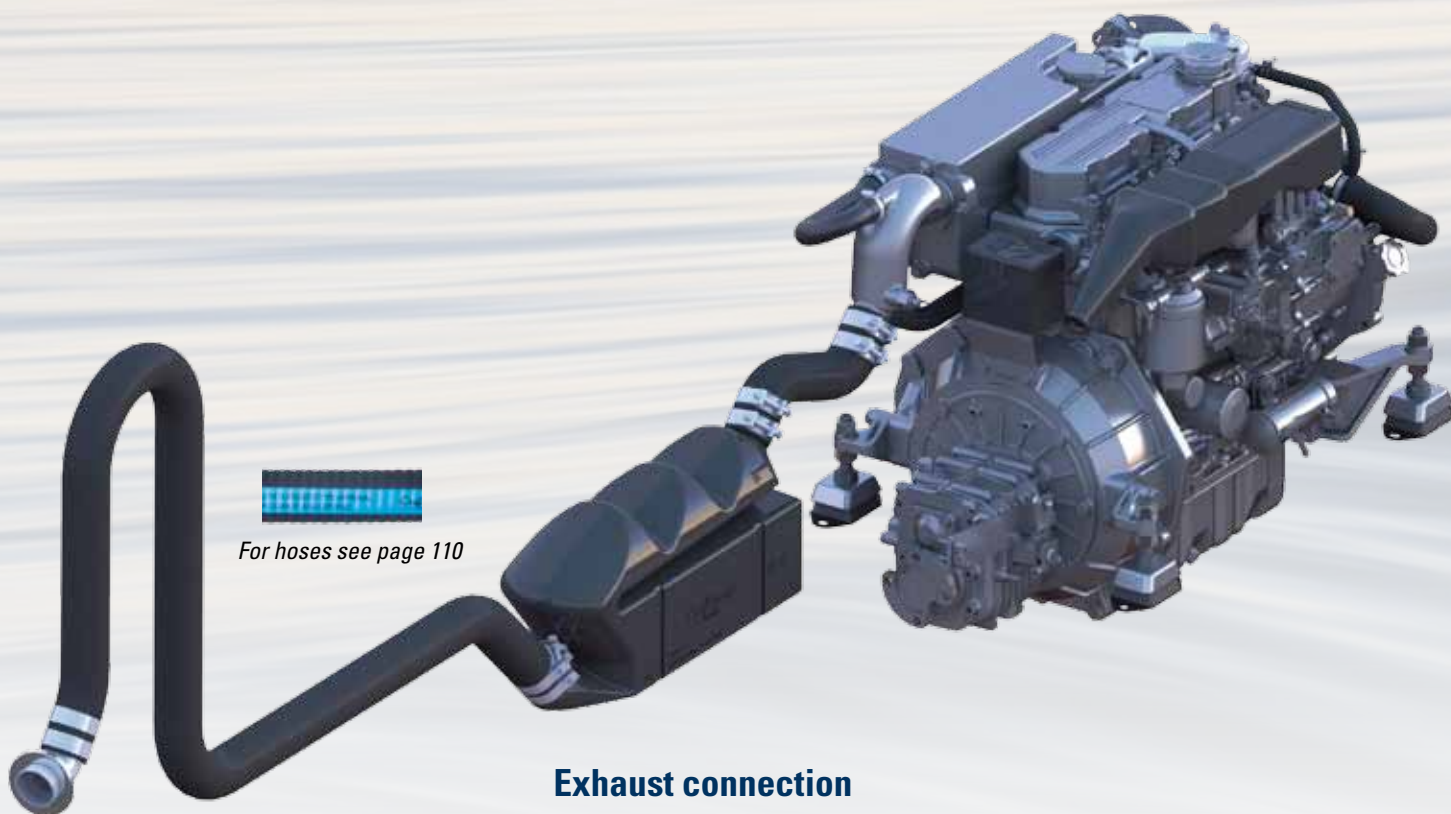

For hoses see page 110

## Exhaust connection

Craftsman Marine offers **polished stainless steel** and composite exhaust connections with a **polished high gloss stainless steel ring**, which also covers the screws. The angled exhaust connections make it easy to use the exhaust hose as a goose neck.

**NEW**



**TIP!**

An engine with an indirect cooling system (with heat exchanger) itself can run "dry" for a couple of minutes, without raw water cooling. But the components of the exhaust system can most certainly NOT! The impeller of the raw cooling water pump will be damaged soon, if forced to run dry. Therefore, before starting the engine, always make sure that the raw water seacock is opened.

	Angled	Straight	Stainless steel
ø30	AC.050.25530	-	-
ø40	AC.050.25540	AC.050.20040	AC.050.21040
ø45	-	AC.050.20045	AC.050.21045
ø50	AC.050.25550	AC.050.20050	AC.050.21050
ø60	AC.050.25560	AC.050.20060	AC.050.21060
ø76	AC.050.25576	AC.050.20076	AC.050.21076
ø90	-	-	AC.050.21090
ø100	-	-	AC.050.21100

## Most engine installations feature a wet exhaust system

When using a wet exhaust system, the gases from the engine are mixed with raw cooling water from the heat exchanger. The lower temperature in the exhaust not only makes the use of synthetic materials possible, but also reduces the sound level. In order to reduce the noise level even further, an additional silencer may be installed. In addition to a silencer, a proper assembly also needs a water lock. The function of a water lock is to collect the cooling water when the engine is stopped, so that the water cannot flow back into the engine.

In order to simplify the rather complicated engine installation, Craftsman Marine has combined the silencer and the water lock in one single unit, called the Soundlock. The result is: lower costs and less installation time, whereas the unit takes up less space on board too. Mounting materials are included.



Drain plug from 76mm model and up.

## Patented design combines water lock and silencer in one unique product

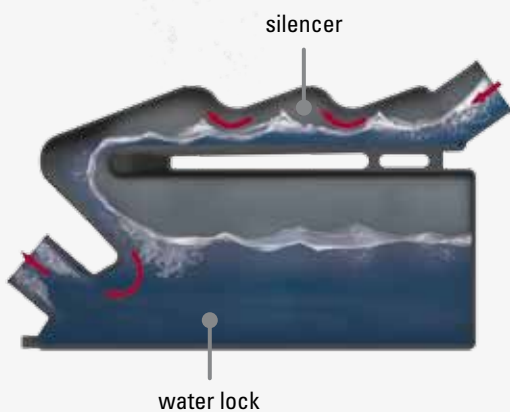

NEW

	30/40MM	50/60MM	76MM	90/100MM
<b>Article code:</b>	AC.010.200xx *	AC.010.200xx *	AC.010.20076	AC.010.20xxx *
<b>Connection exhaust hose:</b>	ø30 / ø40	ø50 / ø60	ø76	ø90 / ø100
<b>Material:</b>	Synthetic	Synthetic	Synthetic	Synthetic
<b>Reservoir volume:</b>	2.6 L	7.0 L	17 L	23 L
<b>Dimensions (mm):</b>	410 x 110 x 190	530 x 150 x 240	620 x 190 x 360	630 x 210 x 395

\* Must be replaced by the desired hose diameter e.g. 40 (for 40 mm).



# CRAFTSMAN MARINE PROPELLER SHAFT ASSEMBLIES

*Especially designed for minimal maintenance and a long lifespan.*

In order to make full use of the power of our engines, Craftsman Marine offers a large variety of essential “around the engine” components. One of the most important parts thereof is the propeller shaft assembly.

Craftsman Marine propeller shafts are made of seawater resistant materials and machined with utmost precision, to ensure both a simple installation procedure and a trouble-free use of your boat.

Well balanced

Manganese bronze

Machined edges to prevent propeller singing

## Propellers

Craftsman Marine propellers are machined with a tapered shaft hole (1:10) and a keyway. They are well balanced and finely machined at the edges, to prevent “propeller singing”. The propellers have a Fa/F ratio of 0,52 (52% blade surface).

For the dimensions of the shaft hole per propeller, please consult the table. Craftsman Marine offers the 4-bladed propellers in both left and right handed from stock. The 3-bladed propellers are available from stock only in right handed propellers (turning to the right).

3-blade	Shaft diameter (mm)	Key (mm)	Hub length (mm)
12" - 15"	ø25	8	60
16" - 18"	ø30	8	80
19" - 21"	ø35	10	90

**NEW**

4-blade	Shaft diameter (mm)	Key (mm)	Hub length (mm)
21" - 22"	ø40	12	100

*Other sizes and configurations are available on request.*

You can easily compose the article code with the aid of the data below.

### For instance:

The code for a propeller with 17" diameter and a pitch of 14" reads: AE.010.17142.

This propeller suits a ø30 mm propeller shaft.

Article code	<b>B</b>	<b>D</b>	<b>P</b>
<b>A</b>	<b>E</b>	<b>0</b>	<b>0</b>
			<b>2</b>

### B Blades

1 3-blades

2 4-blades

### D Diameter

12 12"

up to 22"

### P Pitch

07 7"

up to 21"

## Propellers

Top class material casting, balancing, finishing and quality control are the elements that determine an excellent propeller.

Craftsman Marine propellers are made of manganese bronze, which makes them not only extremely strong, but also sufficiently flexible to cope with solid obstacles under water (logs, sandy bottom, etc.) And in the case of severe damage, the propeller can almost always be repaired and restored to its original state.

Your Craftsman Marine dealer will gladly advise you about the right propeller, in combination with your boat, engine and gearbox.



## Stern tubes

Made of seawater resistant brass, featuring a cutlass bearing at one end. In order to replace the outside bearing in an effortless manner, the tube is provided with two slits. **Available in lengths from 500 to 2500mm.**



**NEW: NOW ALSO AVAILABLE FOR 40 MM**

Article code	For shaft (mm)	Outside diameter (mm)
AD.020.225xx	ø25	ø40
AD.020.230xx	ø30	ø45
AD.020.235xx	ø35	ø55
AD.020.240xx	ø40	ø60

Article code

A D . 0 2 0 . 2 D L

**D** For shaft diameter

25	25 mm
30	30 mm
35	35 mm
40	40 mm

**L** Length

05	0.50 mtr
10	1.00 mtr
15	1.50 mtr
20	2.00 mtr
25	2.50 mtr

## Propeller shafts

Craftsman Marine propeller shafts are made of stainless steel, type Duplex 1.4462.

Duplex 1.4462 is the combination of the best properties of all types of stainless steel. The result is an excellent resistance against pit corrosion and it is even **more rustproof than AISI 316**. Duplex steels are magnetic, a property that can be used to easily differentiate them from common austenitic grades of stainless.

The elastic limit (or: yield point), which is more than double that of AISI 316, a lower expansion coefficient and less tendency to torsion, make this the ideal basic material for a top notch propeller shaft.

Craftsman Marine propeller shafts are carefully straightened and fine-machined, complete with taper 1:10, keyway and thread for the nut cap. Key, brass nut cap and zinc anode are included. **Available from 1 to 3 metres with 0.5 metre increments.**

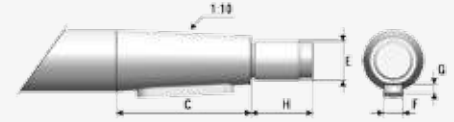

B (mm)	C (mm)	D (mm)	E	F (mm)	G (mm)	H (mm)
39	55	ø25	M16x1.5	8	3	25
52	75	ø30	M20x1.5	8	3	30
54	85	ø35	M24x2	10	3	35
64	95	ø40	M24x2	12	3	35

L = length in decimetre.

Article code						D	L
A	D	.	0	1	0	.	2

## Anodes

To protect your installation against galvanic corrosion Craftsman Marine offers sacrificial anodes that fit on the propeller shaft.



Shaft	Zinc
ø25	AD.010.91025
ø30	AD.010.91030
ø35 / ø40	AD.010.91035

## Mounting flanges

Made from seawater resistant bronze, these flanges are perfect to mount the Craftsman Marine stern tubes.

The outer flange incorporates a rubber O-ring to seal perfectly on the tube and keep your boat dry while keeping the possibility to replace the stern tube easily without the need of re-embedding the flange to the hull.



Article code*	For shaft (mm)	Stern tube (mm)
AD.040.22025	ø25	ø40
AD.040.22030	ø30	ø45
AD.040.22035	ø35	ø55
AD.040.22040	ø40	ø60

\* Set includes inner and outer flanges.

## Flexible inner bearings

**No leaking propeller shaft anymore! Doesn't that sound great? This is ensured by using a Craftsman Marine water-lubricated inner bearing.**

Made of bearing bronze and provided with a dual Viton seal, which ensures a care-free propeller shaft sealing. Being almost maintenance-free the bearing takes care of a dry bilge for many, many years to come. Water lubrication by means of the exhaust water coming from the engine or through a separate water scoop. The unit is supplied complete with high quality silicone grease for the seals.



Article code	For shaft (mm)	Total Length (mm)
AD.040.21025	ø25	134
AD.040.21030	ø30	134
AD.040.21035	ø35	160
AD.040.21040	ø40	160

## Flexible coupling GYRO FLEX

By fitting a flexible coupling between the gearbox and the propeller shaft, vibrations in the boat are largely eliminated. The flexible coupling ensures less vibrations and less noise to a great extent. The average noise reduction amounts to about 5 dBa, or up to 30%. Misalignment of the propeller shaft can also be compensated, with the result that gearbox and shaft bearing are less subjected to wear and tear.

- High elasticity and free from lateral and axial clearance are the characteristics that dampen the engine vibrations. The effect is even more noticeable at lower engine revolutions.
- Contact noise is insulated to around 5 dBa, or up to 30%.
- The flexible coupling compensates small misalignments, especially angular misalignments, thus ensuring less wear and tear of the gearbox and of the shaft bearings.
- The axial thrust of the propeller shaft, both forward and backwards, is transmitted to the thrust bearing inside the gearbox.
- The connection with the propeller shaft is made by a cylindrical clamping box, so that further machining of the propeller shaft is not required.
- The coupling is electrically insulating, therefore offering good protection against electrolysis.
- Maximum misalignment error of the propeller shaft is permitted up to 2°.



Temperatures are allowed between – 45 and + 80°C

Article code	For shaft	Diameter	For gearbox	Weight	Max. axial thrust	Torque (pleasure craft)	Torque (commercial vessels)
AI.030.22025	ø25	101 mm	ZF and TMC	2.1 kg	2.1 kN	280 Nm	175 Nm
AI.030.22030	ø30	101 mm	ZF and TMC	2.1 kg	2.1 kN	280 Nm	175 Nm
AI.030.24030	ø30	132 mm	ZF and TMC	3.9 kg	4.2 kN	560 Nm	350 Nm
AI.030.24035	ø35	132 mm	ZF and TMC	3.9 kg	4.2 kN	560 Nm	350 Nm

# CRAFTSMAN MARINE VECTOR DRIVE

*More comfort, less wear and maintenance. The installation of a Craftsman Marine Vector Drive results in an enormous reduction of engine vibrations and noise. Less vibrations always result in less wear, meaning lower maintenance cost and longer life of all the components in your drive train, including the engine itself.*

## Vector Drive

The vector drive is available for shaft torques up to 1100 Nm and thrust forces up to 11,5 kN.

- Maintenance free and no more need for yearly engine alignment
- Standard supplied with a 4" adapter flange, suited for all common types of gearboxes.
- Supplied complete with all installation materials (nuts, bolts, washers, etc.)
- Easy accessible clamping hub, which is self centering and self adjusting.  
No need for a torque wrench! Easy detachment of the propeller shaft.
- Less wear of engine, engine mounts, transmission, propeller shaft and bearings.
- Constant velocity (CV) shaft available in different lengths.
- Permissible angles up to 8° per side of the CV shaft
- Compensates propeller shaft angles
- Reduction of vibrations and noise
- Easy installation



Type	Max. torque	Max. trust	Bearing Length (Lb)	Bearing Diameter (D)	Adapter Length (La)	Bolts (B)	Bolt Spacing (S)
600	600 Nm	6 kN	85 mm	114.5 mm	21 mm	M12	157 mm
800	800 Nm	8 kN	110 mm	148 mm	21 mm	M12	170 mm
1100	1100 Nm	11.5 kN	120 mm	148 mm	25 mm	M12	170 mm



## How it works

When not using a Vector Drive, the propeller shaft is directly attached to the gearbox (whether using a flexible coupling or not. This has two undesirable results: the engine vibrations are transferred to the rest of the drive train and the rest of the boat. Secondly the thrust force generated by the propeller is transferred to the engine.

The drive is installed between the gearbox and inner bearing. The propeller shaft is fixed in the thrust bearing, which is attached to the hull to transfer the thrust force. The connection between the bearing and gearbox is made by the double headed constant velocity shaft. Both ends of this shaft can make an angle of up to 8 degrees, while transferring the rotation at a constant velocity.

This results in the following:

- Alignment of engine and propeller shaft is less critical. Neither during installation nor during yearly maintenance.
- The engine can move independent of the propeller shaft. No vibrations are transferred.
- Because the flexible engine mounts no longer have to absorb the thrust force a softer type can be used. These softer mounts absorb more vibrations.

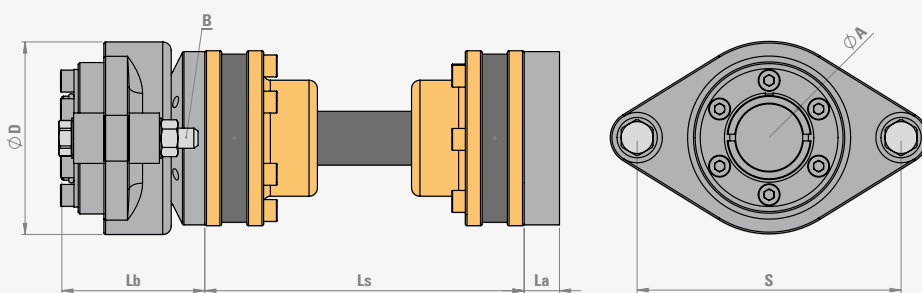

### TIP!

When selecting the drive that suits your installation, use the torque on the propeller shaft. You can calculate this by multiplying the max. engine torque with the reduction of the gearbox.

For example: If your engine has a max. torque of 105 Nm and a gearbox with a reduction of 1.93 the propeller shaft torque is  $105 * 1.93 = 202.65$  Nm.

Type	Shaft (mm) Diameter (A)	CV shaft length (Ls)				
		147 mm	167 mm	182 mm	197 mm	227 mm
600	25 mm	AI.020.26011	AI.020.26021		AI.020.26031	
	30 mm	AI.020.26012	AI.020.26022		AI.020.26032	
	35 mm	AI.020.26013	AI.020.26023		AI.020.26033	
	40 mm	AI.020.26014	AI.020.26024		AI.020.26034	
800	35 mm	AI.020.28011	AI.020.28021		AI.020.28031	
	40 mm	AI.020.28012	AI.020.28022		AI.020.28032	
	45 mm	AI.020.28013	AI.020.28023		AI.020.28033	
1100	35 mm			AI.020.21111		AI.020.21121
	40 mm			AI.020.21112		AI.020.21122
	45 mm			AI.020.21113		AI.020.21123

Sizes available on request.

## Mechanical remote control QUADRA

To complete the beautifully finished range of engine panels and control panels, a mechanical engine remote control in matching style is available.

Single lever control of your engine and gearbox. Solidly engineered it will provide smooth control for the life of your boat. Ball bearings minimise friction and corrosion resistant materials make sure minimum maintenance is required. Can be mounted from the outside. Prepared for an optional neutral safety switch.

Especially with dual station controls, the optional neutral safety switch is essential. It prevents that the engine is started with the gears engaged. The switch can be easily implemented in a Craftsman Marine engine installation.

Neutral safety switch: **AF.030.20000**



## Mechanical remote control CIRCA

Single lever remote control for side mounting. Available in a classic and modern design. Both types are fitted with a safety lock switch to prevent the gear to be engaged accidentally. The handle is made from durable plastic material.

## Push-Pull cables

The Craftsman Marine push-pull cables ensure a smooth operation of engine and gearbox. They can be installed with a small bend radius. However, a bend radius as large as possible is recommended for lower friction and wear.

Travel: 90mm  
Thread: 10-32 UNF



Article code	Length	Article code	Length
AF.020.20005	0.5 m	AF.020.20055	5.5 m
AF.020.20010	1.0 m	AF.020.20060	6.0 m
AF.020.20015	1.5 m	AF.020.20065	6.5 m
AF.020.20020	2.0 m	AF.020.20070	7.0 m
AF.020.20025	2.5 m	AF.020.20075	7.5 m
AF.020.20030	3.0 m	AF.020.20080	8.0 m
AF.020.20035	3.5 m	AF.020.20085	8.5 m
AF.020.20040	4.0 m	AF.020.20090	9.0 m
AF.020.20045	4.5 m	AF.020.20095	9.5 m
AF.020.20050	5.0 m	AF.020.20100	10.0 m

## Single engine control VECTRA

Stainless steel look with high quality chrome finish, to give your boat that classic look. There is no easier way to control your engine with the dual function lever. Operate your gear and throttle with a single lever. Standard fitted with a neutral safety switch to prevent start in gear (when connected) and engine warm-up feature. Top mounted.



## Dual engine control VECTRA

The same stainless steel classic looks but now for twin engine control. These controls incorporate dual function levers, standard neutral safety switch and engine warm-up feature. It has never been easier to control both your engines with a single control.



## Dual lever, single engine control MARINE

Each lever controls throttle or shift for the ultimate control of your engine with the time proven classic design. Standard neutral safety switch. Top mounted. Recommended for long or difficult cableruns.



## Dual Station unit

The Dual Station unit makes it possible to install a second remote control in your boat. Now you can control your engine outside when docking or inside your pilothouse when it's raining cats and dogs.

Craftsman Marine 4-cylinder engines are standard equipped for double throttle cables, so the Dual Station unit is only needed for the gearbox. It is best to mount the unit on the engine to accommodate vibrations. Made from corrosion resistant materials to minimise maintenance.





*Craftsman Marine Benelux (The Netherlands)*  
*Boat: Portland 780 Classic*  
*Engine: CM4.42*

## Water strainers

Make sure that you have an efficient raw water flow to your engine, by including a water strainer into the suction line. Even small dirt particles can damage the impeller of the water pump, or are the cause of clogging-up in the cooling water channels in the longer run.

The water strainer must be fitted above the waterline, so that there is no water intrusion when the seacock is not closed while opening the filter.

Having a water strainer installed, this facilitates the adding of anti-freeze to the raw water circuit, when winterizing the engine. The filter element can easily be removed and cleaned and the transparent cover enables an efficient checking of the water flow.



Article code	Hose connections
AG.010.20019	ø19
AG.010.20025	ø25

Raw water strainer	side/side connection	side/bottom connection
Bronze 1"	AG.015.20025	AG.015.25025
Bronze 1" 1/4	AG.015.20032	AG.015.25032
Bronze 1" 1/2	AG.015.20038	AG.015.25038
Bronze 2"	AG.015.20051	AG.015.25051



## Fuel filter with water separator

A first class fuel system contains a primary and a secondary fuel filter. The secondary filter on the engine is standard with each Craftsman Marine engine, but the primary filter – preferably incorporating a water separator - is often positioned into the fuel system as an extra. When this filter is not fitted, the secondary filter on the engine will be clogged up much sooner. Also the proper functioning of the fuel lift pump can be impeded by even small particles of dirt in the fuel.

Replace the filters in accordance with the prescribed service intervals. The cost of a filter is next to nothing, compared with the inconvenience of a stalled engine and the possible danger it entails.



Article code	Description	Connection pillars	Micron
AH.010.20008	Water separator 180ltr	8 mm	10
AH.010.90001	Water separator element	N/A	10

# CRAFTSMAN MARINE ENGINE PANELS

*The engine control panel enables the skipper to control the engine and monitor the status of the engine at a glance.*



ALFA 10E

AB.010.20000

ALFA 30E

BLACK GAUGES

AB.030.20000

WHITE GAUGES

AB.030.20001

*\* Supplied with front seal, fasteners, dust cap for starter switch and 3 keys.*



ALFA 20E

WHITE GAUGES

AB.020.20001

BLACK GAUGES

AB.020.20000



ALFA 40E

AB.040.20000



## Engine Panels

A wide range of panels available with several types of gauges. With the ALFA40 panel and separate gauges you can even create your own dashboard by fitting the gauges in your own style. Each panel is machined out of a solid plate of aluminium and anodised for maximum protection against weather influences.

All our panels come completely pre-wired, including a multi-plug and splashproof cover for the ignition switch. Gauges with double glazing are used to prevent condensation inside; you will have a clear read-out at all times.

A well-considered beautiful design that suits every boat! Remember, the panel is the only item you will see after the installation of your engine.



### ALFA20

Pre-wired cabling to replace the voltmeter with a temperature gauge.



### Alarm indication with LED's on all panels, including acoustic alarm.

Replacement of alarm lights is history.







- Waterproof connectors IP67
- Rear cover, protection of electrical parts (not for ALFA40)
- Easy calibration of the tachometer with the supplied stylus
- Double connection on the Voltmeter to interconnect the backlight power supply of other gauges (fuel, water, waste water, etc.)
- All gauges are provided with backlight. When using the optional automatic dimmer module the backlight of these instruments will dim
- Tachometer with digital hour counter. Starts counting when the speed of the engine is above 400 rpm

- Ultraviolet sunlight resistant foil at the front
- Double glass, to prevent condensation
- Stainless steel screws
- Gasket for dashboard mounting
- Ignition switch with re-start protection  
Supplied with 3 keys. Dust cover included.
- Printed wiring board with conformal coating for protection against humidity



IP66 PROTECTION ON FRONT SIDE



-   
 High exhaust temperature
-   
 Low oil pressure in engine
-   
 Battery charging current
-   
 Sensor for backlight dimmer module (not for ALFA10)
-   
 Temperature inner cooling circuit
-   
 Pre-heating of the engine
-   
 Low oil pressure in the gearbox (optional)



	ALFA 10E	ALFA 20E	ALFA 30E	ALFA 40E
<b>Power supply:</b>	12V DC	12V DC	12V DC	12V DC
<b>Automatic dimmer:</b>	-	Optional	Optional	Optional
<b>Revolution/hour counter:</b>	-	✓	✓	Optional
<b>Voltmeter:</b>	-	✓	✓	Optional
<b>Temperature gauge:</b>	-	Optional	✓	Optional
<b>Oil pressure gauge:</b>	-	-	✓	Optional
<b>Automatic pre-heating:</b>	Optional	Optional	Optional	Optional
<b>Panel dimensions:</b>	100 x 166 mm	198 x 166 mm	260 x 166 mm	150 x 50 mm
<b>Built-in dimensions:</b>	76 x 138 mm	175 x 143 mm	237 x 143 mm	102 x 34 mm
<b>Built-in depth:</b>	114 mm	114 mm	114 mm	114 mm

**Create your personal instrument panel**  
 Panel supplied with ignition switch, pre-wired cables for temperature gauge, oil pressure gauge, voltmeter and tachometer.

Easy plug-in of the connectors, all wires are labeled.  
 - Cableloom of 50cm in length  
 - Gauges are optional  
 See **page 88** for more details.

# CRAFTSMAN MARINE THRUSTERS

*Bow and stern thrusters have become an important device when moving at low speed. It makes manoeuvring easier, safer and quicker.*

Thrusters for pleasure craft have to be small, easy to install, reliable, efficient, long-lasting and easy to handle from the console. The robust and versatile Craftsman Marine thrusters meet all these requirements.

Our thruster propellers are designed to achieve maximum thrust in a relatively small tunnel diameter. Made of maintenance-free synthetic material, these propellers are capable to run in both directions, producing thrust to port and starboard. Depending on

your hull structure, length and your vessel's water displacement, you can select the right thruster for your vessel.

***Craftsman Marine specifies the average force of the thrusters, however the starting peak force (1 second) can be easily 60% higher.***

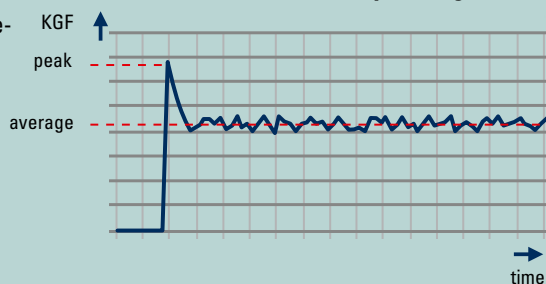

FAN for extra cooling  
(except for 55 kgf)

Easy accessible battery  
connection terminals



Oil expansion tank for models  
125 kgf, 150 kgf and 170 kgf

Supplied with 1mm and 2mm  
gasket to center the propeller  
inside the tunnel

Optimised 7 blade propeller  
for maximum thrust

Replaceable zinc or  
aluminium anode



Motor temperature  
protection switch

Protection cover for  
electrical components



5A circuit breaker for  
the control panel

Waterproof and latch lock connector for  
the control panel. A 100% guaranteed  
connection also in case of vibrations.

Flexible coupling to  
absorb vibrations

Brass tail piece



## Thruuster selection

Choosing the right thruuster for your boat is not easy. Many factors play a role when making a selection. Not only the length and height of the boat is important, but also the type of boat. A light displacement boat requires less force to manoeuvre than a heavy displacement boat and then there is the weather to take into account.

When the wind speed is twice as much, the wind force acting on the boat is four times as high. So when you always sail with your boat in perfect weather you can choose a smaller thruuster, but when you want to be able to control your boat under all weather conditions you need to install a more powerful thruuster.

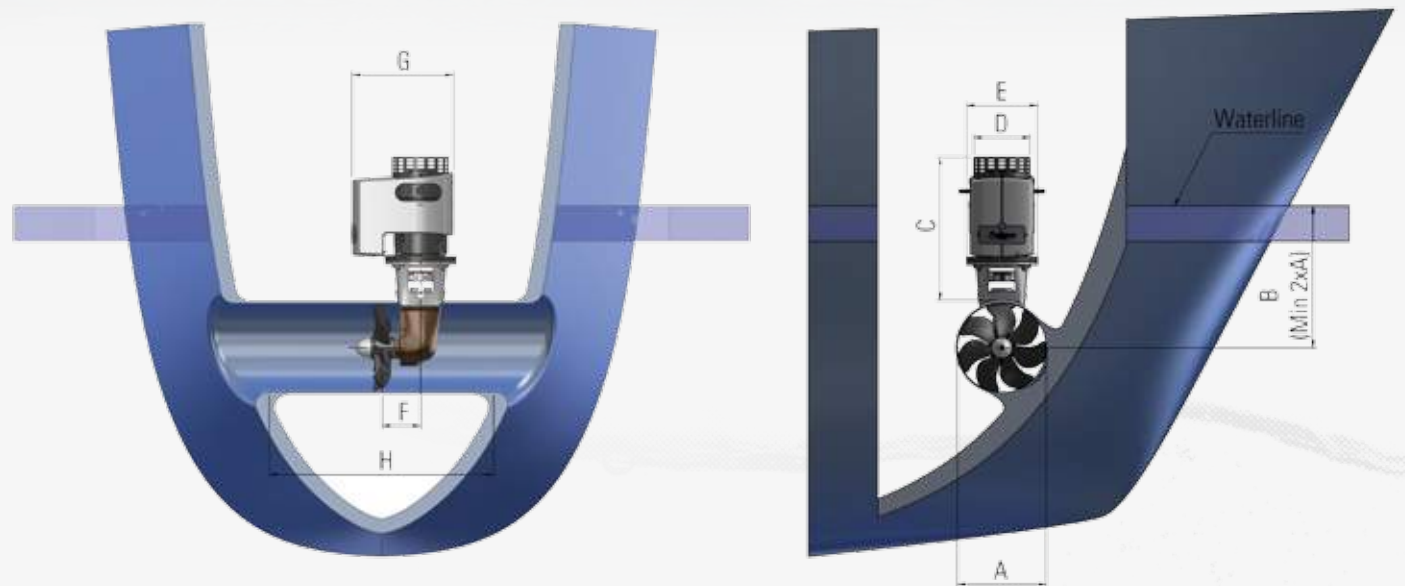

	Thruuster 35kgf 12V	Thruuster 55kgf 12V	Thruuster 80kgf 12V	Thruuster 80kgf 24V	Thruuster 95kgf 12V	Thruuster 115kgf 24V	Thruuster 125kgf 12V	Thruuster 150kgf 24V	Thruuster 170kgf 24V
A	ø110 mm	ø150 mm	ø185 mm	ø185 mm	ø185 mm	ø185 mm	ø250 mm	ø250 mm	ø250 mm
B (min.)	220 mm	300 mm	370 mm	370 mm	370 mm	370 mm	500 mm	500 mm	500 mm
C	276 mm	303 mm	344 mm	307 mm	372 mm	372 mm	404 mm	404 mm	422 mm
D	ø114 mm	ø128 mm	ø126 mm	ø128 mm	ø160 mm	ø160 mm	ø160 mm	ø160 mm	ø172 mm
E	ø175 mm	ø175 mm	ø175 mm	ø175 mm	ø200 mm	ø200 mm	ø200 mm	ø200 mm	ø200 mm
F	68 mm	68 mm	68 mm	68 mm	68 mm	68 mm	115 mm	115 mm	115 mm
G	238 mm	238 mm	238 mm	294 mm	294 mm	294 mm	294 mm	294 mm	301 mm
H (min.)	110 mm	150 mm	185 mm	185 mm	185 mm	185 mm	250 mm	250 mm	250 mm

We have made a thruster selection guide to give you an idea of the thruster suitable for your boat. Your dealer will assist you in selecting the correct thruster.

Follow the steps below to find your Craftsman Marine thruster:

<b>Step 1.</b>	<b>Select your type of boat. In the graph are three boat types: light displacement, medium displacement or heavy displacement.</b> <i>Rotate the graph so that your boat type is facing upward.</i>
<b>Step 2.</b>	<b>Select the length of your boat.</b>
<b>Step 3.</b>	<b>Choose under what wind conditions you want to be able to manoeuvre the boat. You can choose between 4bft, 5bft or 6bft (bft = beaufort).</b>

As you will see, the type of bowthruster can vary by as much as three types depending on the chosen weather conditions. Take into consideration that most of the times manoeuvring will be in a sheltered harbor. Manoeuvring with the wind on the bow will also require less force than wind from the side, so choose your berth carefully. For installation of the biggest thruster possible you not only require batteries with a higher capacity but also thicker cables and bigger fuses.

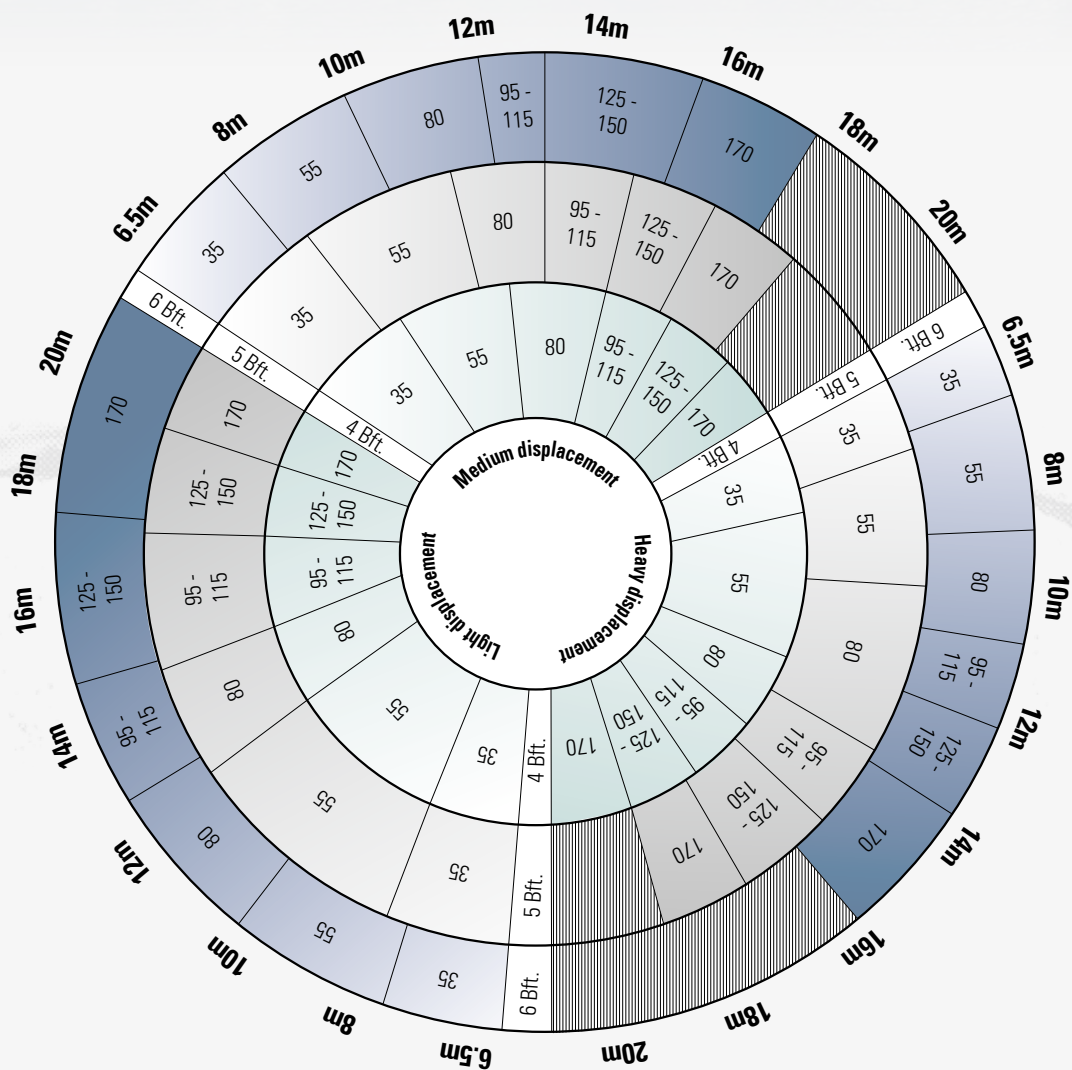



**Optional equipment:** please see page 79 for a complete overview of remote controls.

	THRUSTER 35kgf 12V	THRUSTER 55kgf 12V	THRUSTER 80kgf 12V
<b>Article code:</b>	BA.110.20012	BA.150.20012	BA.185.20012
<b>Thrust force @ 10.5V:</b>	35 kgf	55 kgf	80 kgf
<b>Tunnel diameter:</b>	110 mm	150 mm	185 mm
<b>Power of electric motor:</b>	2.4 kW (3.3 hp)	3.5 kW (4.8 hp)	4.0 kW (5.4 hp)
<b>Motor type:</b>	12V DC	12V DC	12V DC
<b>Motor temperature switch:</b>	✓	✓	✓
<b>Operating time:</b>	2min/hr	2min/hr	2min/hr
<b>Current consumption:</b>	340 A	400 A	420 A
<b>Min. battery capacity: *</b>	105 Ah	140 Ah	140 Ah
<b>Main fuse slow-blow, type ANL: *</b>	250 A	300 A	355 A
<b>Battery cable, total length of plus and minus: *</b>	0-9m / 50mm <sup>2</sup> 9-13m / 70mm <sup>2</sup>	0-6m / 50mm <sup>2</sup> , 6-11m / 70mm <sup>2</sup> 11-14m / 95mm <sup>2</sup>	0-10m / 70mm <sup>2</sup> 10-14m / 95mm <sup>2</sup>
<b>Connection battery cable:</b>	M8	M10	M10
<b>Weight:</b>	12 kg	18 kg	19 kg

\* The recommended battery capacity, and cable ratings are based on an operation time of 2 minutes. Short cable lengths in combination with a higher battery capacity may overheat the electromotor. Depending on the boat installation and the distance between thruster and battery, other ratings can be chosen. All thrusters are fitted with a zinc anode as standard. Aluminium anodes are available separately.



**Optional equipment:** please see page 82 for a complete overview of the battery main switches.



	THRUSTER 80kgf 24V	THRUSTER 95kgf 12V	THRUSTER 115kgf 24V
<b>Article code:</b>	BA.185.20024	BA.185.25012	BA.185.25024
<b>Thrust force @ 10.5V:</b>	80 kgf	95 kgf	115 kgf
<b>Tunnel diameter:</b>	185 mm	185 mm	185 mm
<b>Power of electric motor:</b>	4.0 kW (5.4 hp)	5.95 kW (8.1 hp)	5.95 kW (8.1 hp)
<b>Motor type:</b>	24V DC	12V DC	24V DC
<b>Motor temperature switch:</b>	✓	✓	✓
<b>Operating time:</b>	2min/hr	2min/hr	2min/hr
<b>Current consumption:</b>	240 A	640 A	320 A
<b>Min. battery capacity: *</b>	2*95 Ah	2*180 Ah	2*105 Ah
<b>Main fuse slow-blow, type ANL: *</b>	200 A	425 A	250 A
<b>Battery cable, total length of plus and minus: *</b>	0-19m / 35mm <sup>2</sup> 19-27m / 50mm <sup>2</sup>	0-9m / 95mm <sup>2</sup> 9-12m / 120mm <sup>2</sup>	0-20m / 50mm <sup>2</sup> 20-28m / 70mm <sup>2</sup>
<b>Connection battery cable:</b>	M10	M10	M10
<b>Weight:</b>	17 kg	25 kg	25 kg



*Optional equipment: please see page 80 for a complete overview of the fuse and fuse holder.*

	THRUSTER 125kgf 12V	THRUSTER 150kgf 24V	THRUSTER 170kgf 24V
<b>Article code:</b>	BA.250.20012	BA.250.20024	BA.250.25024
<b>Thrust force @ 10.5V / 21V:</b>	125 kgf	150 kgf	170 kgf
<b>Tunnel diameter:</b>	250 mm	250 mm	250 mm
<b>Power of electric motor:</b>	6.5 kW (8.8 hp)	6.5 kW (8.8 hp)	11.3 kW (15.4 hp)
<b>Motor type:</b>	12V DC	24V DC	24V DC
<b>Motor temperature switch:</b>	✓	✓	✓
<b>Operating time:</b>	2min/hr	2min/hr	2min/hr
<b>Current consumption:</b>	750 A	380 A	520 A
<b>Min. battery capacity: *</b>	2*230 Ah	2*105 Ah	2*180 Ah
<b>Main fuse slow-blow, type ANL: *</b>	500 A	250 A	355 A
<b>Battery cable, total length of plus and minus: *</b>	0-10m / 120mm <sup>2</sup> 10-13m / 150mm <sup>2</sup>	0-23m / 70mm <sup>2</sup> 23-31m / 95mm <sup>2</sup>	0-23m / 95mm <sup>2</sup> 23-30m / 120mm <sup>2</sup>
<b>Connection battery cable:</b>	M10	M10	M10
<b>Weight:</b>	33 kg	33 kg	38 kg

*\* The recommended battery capacity, and cable ratings are based on an operation time of 2 minutes. Short cable lengths in combination with a higher battery capacity may overheat the electromotor. Depending on the boat installation and the distance between thruster and battery, other ratings can be chosen.*

*All thrusters are fitted with a zinc anode as standard. Aluminium anodes are available separately.*

## Stern Thruster tunnel deluxe

Craftsman Marine stern thruster tunnels are built from a glassfiber reinforced polyester filled with PU foam. This sandwich construction creates a great look and helps to reduce noise.

Shallow draft vessels might need an additional deflection kit to use the stern tunnel. These additional covers are mounted on the tunnel and minimise the amount of false air being sucked into the tunnel.



Article codes		150 mm	185 mm
<b>BB.010.20150</b>	Stern thruster tunnel 150mm	<b>H</b> 225	230
<b>BB.050.20150</b>	Deflection covers 150mm	<b>ID</b> 150	185
		<b>L</b> 300	330
<b>BB.010.20185</b>	Stern thruster tunnel 185mm	<b>L1</b> 155	190
<b>BB.050.20185</b>	Deflection covers 185mm	<b>W</b> 208	236.5

## Anodes

The anodes are available in both **zinc** and **aluminium**. For boats that are mainly used on fresh water aluminium is advised, while zinc is best suited for salt water applications.



Thruster	Aluminium	Zinc
35 kgf	BA.110.95007	BA.110.90007
55 kgf	BA.150.95007	BA.150.90007
80 / 95 / 115 kgf	BA.185.95007	BA.185.90007
125 / 150 / 170 kgf	BA.250.95007	BA.250.90007

## Stern Thruster tunnel basic

When aesthetics are less important the new more simple stern thruster tunnel is the choice for you. It is strong and functional but lacks the elegance that made the original Craftsman Marine stern thruster stand out.

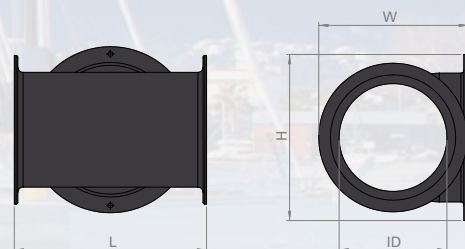

	BB.010.25150	BB.020.25185	BB.020.25250
<b>H</b>	260	285	285
<b>ID</b>	150	185	250
<b>L</b>	300	330	450
<b>W</b>	221.5	242	322

GRP: Glassfiber reinforced polyester

## Thruster Tubes

Craftsman Marine supplies the required tunnels in various lengths and diameters. The diameter of the tunnel depends on the chosen thruster. Tubes are made from steel or GRV (glassfiber reinforced vinylester). Vinylester is equally strong as polyester but does not absorb water.



Article codes	
<b>BG.110.21100</b>	GRV tunnel 110mm L=1.000mm
<b>BG.110.21300</b>	GRV tunnel 110mm L=3.000mm
<b>BG.150.21100</b>	GRV tunnel 150mm L=1.000mm
<b>BG.150.21300</b>	GRV tunnel 150mm L=3.000mm
<b>BG.185.21100</b>	GRV tunnel 185mm L=1.000mm
<b>BG.185.21300</b>	GRV tunnel 185mm L=3.000mm
<b>BG.250.21100</b>	GRV tunnel 250mm L=1.000mm
<b>BG.250.21150</b>	GRV tunnel 250mm L=1.500mm
<b>BG.110.22100</b>	Steel tunnel 110mm L=1.000mm
<b>BG.150.22100</b>	Steel tunnel 150mm L=1.000mm
<b>BG.185.22100</b>	Steel tunnel 185mm L=1.000mm
<b>BG.250.22100</b>	Steel tunnel 250mm L=1.000mm



# HYDRAULIC THRUSTERS FOR YOUR BOAT

Use the following performance curves to check the necessary flow and pressure for your hydraulic thruster.

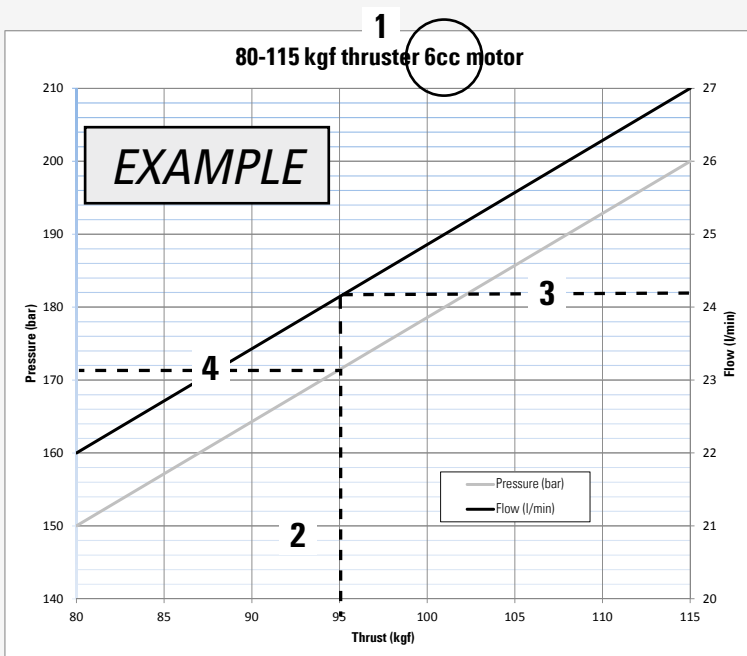

1. Carefully check if the correct thruster is selected with the correct hydraulic motor.
2. Choose the desired thrust in the bottom of the graph and draw a vertical line upwards.
3. Where the vertical line intersects the black line, draw a horizontal line to the right and find the necessary flow.
4. Where the vertical line intersects the grey line, draw a horizontal line to the left and find the necessary pressure.

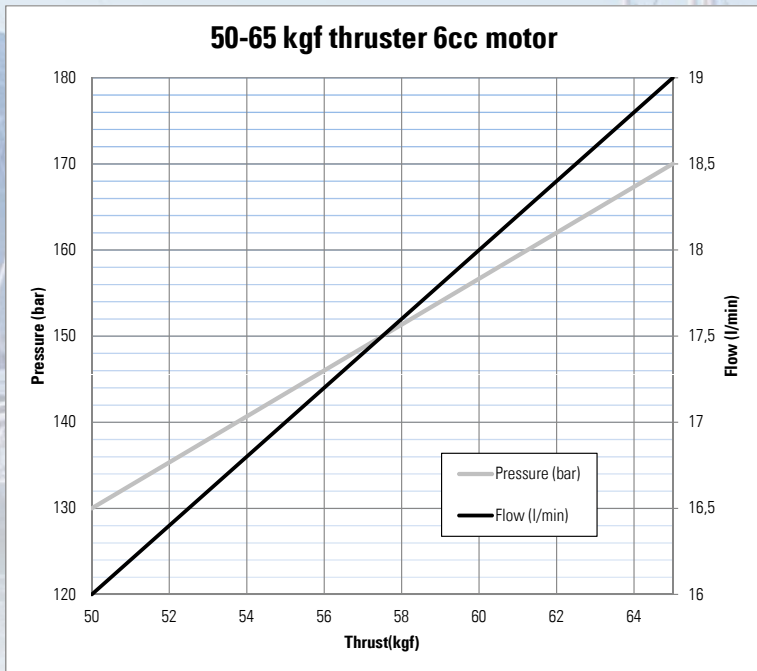

Article code	Thrust (kgf)	Inside diameter of tunnel	Weight (kg)	Hydraulic motor (cc/rev)	Power (kW)	Pressure (bar)	Flowrate (l/min)	Hose connections	Drain
BA.150.20006	50-65	150 mm	6.5	6	3-3.8	130-170	16-19	G1/2	G1/4

## HYDRAULIC THRUSTER 50-65 KGf 6CC MOTOR

### Assets:

- Maintenance-free synthetic propeller
- Unlimited run time
- Durable hydraulic gearmotor
- Easy access zinc or aluminium anode
- High quality hydraulic components
- Optimised propeller design for maximum efficiency

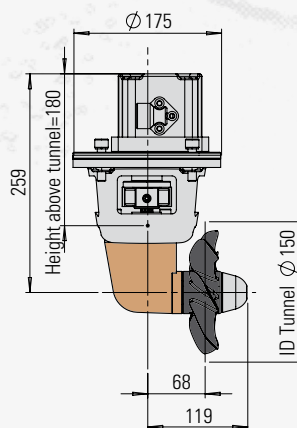

### Optional



ALFA 10H  
BC.010.25010

See **page 67** for the complete range of thruster panels.

All thrusters are fitted with a zinc anode as standard. Aluminium anodes are available separately.

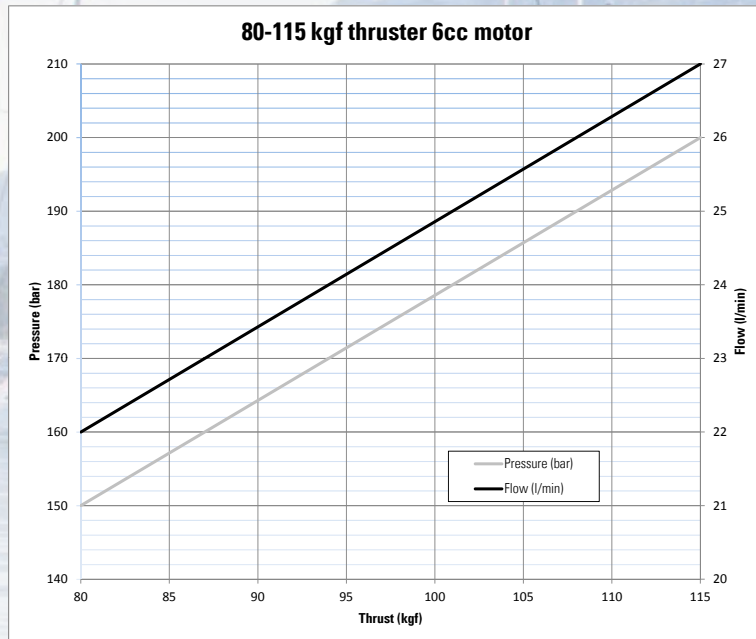

Article code	Thrust (kgf)	Inside diameter of tunnel	Weight (kg)	Hydraulic motor (cc/rev)	Power (kW)	Pressure (bar)	Flowrate (l/min)	Hose connections	Drain
BA.185.20006	80-115	185 mm	8	6	4-6	150-200	22-27	G1/2	G1/4

## HYDRAULIC THRUSTER 80-115 KGF 6CC MOTOR

### Assets:

- Maintenance-free synthetic propeller
- Unlimited run time
- Durable hydraulic gearmotor
- Easy access zinc or aluminium anode
- High quality hydraulic components
- Optimised propeller design for maximum efficiency

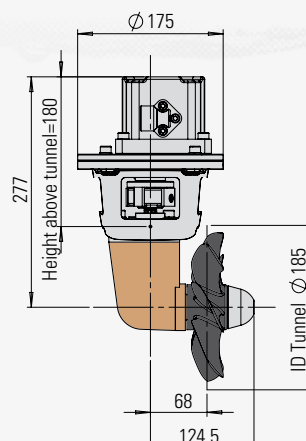

### Optional



ALFA 10R

BC.020.20010

See **page 79** for the complete range of remote controls.

All thrusters are fitted with a zinc anode as standard. Aluminium anodes are available separately.

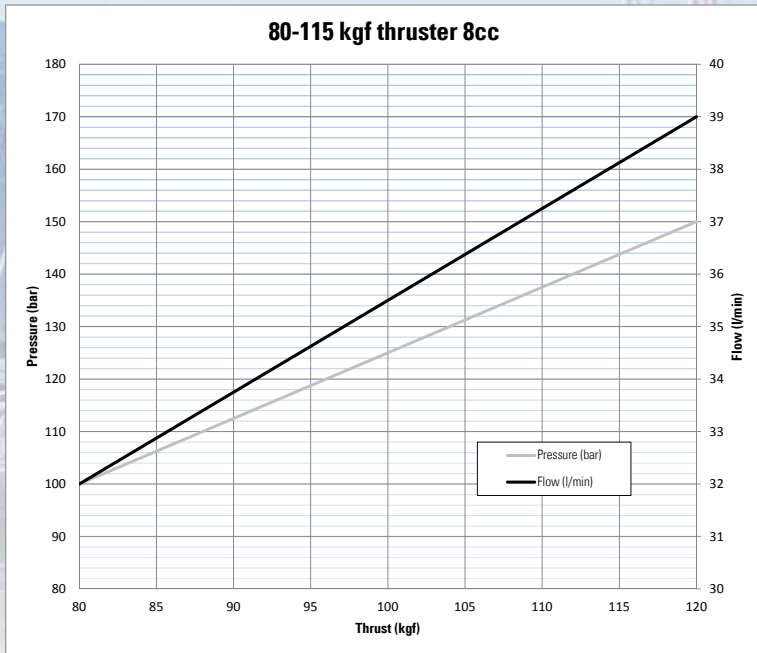

Article code	Thrust (kgf)	Inside diameter of tunnel	Weight (kg)	Hydraulic motor (cc/rev)	Power (kW)	Pressure (bar)	Flowrate (l/min)	Hose connections	Drain
BA.185.20008	80-115	185 mm	8	8	4-6	100-150	32-39	G1/2	G1/4

## HYDRAULIC THRUSTER 80-115 KGf 8CC MOTOR

### Assets:

- Maintenance-free synthetic propeller
- Unlimited run time
- Durable hydraulic gearmotor
- Easy access zinc or aluminium anode
- High quality hydraulic components
- Optimised propeller design for maximum efficiency

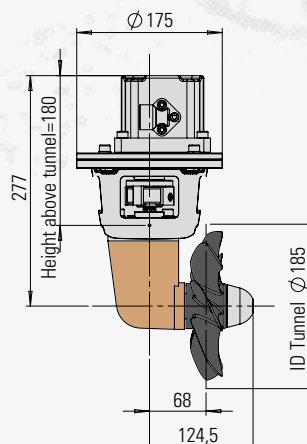

### Optional



See **page 67** for the complete range of thruster panels.

All thrusters are fitted with a zinc anode as standard. Aluminium anodes are available separately.

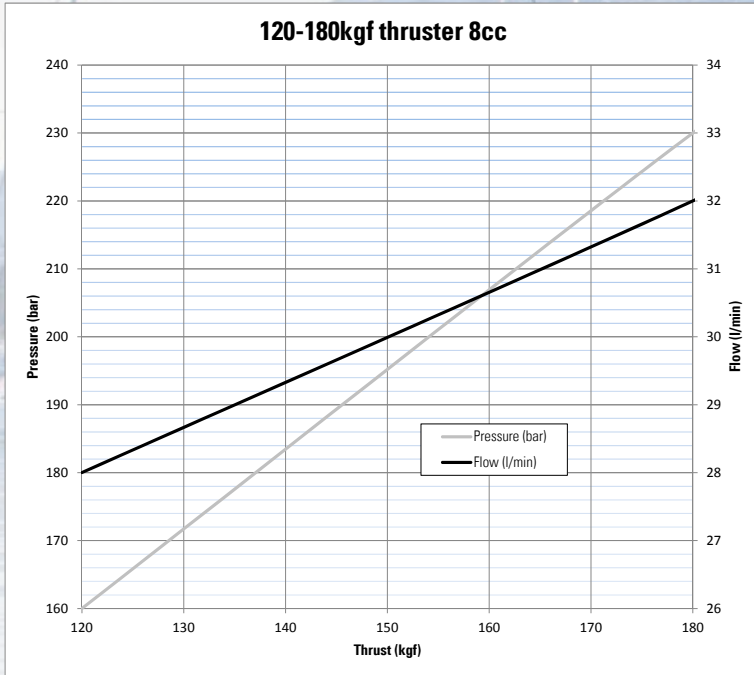

Article code	Thrust (kgf)	Inside diameter of tunnel	Weight (kg)	Hydraulic motor (cc/rev)	Power (kW)	Pressure (bar)	Flowrate (l/min)	Hose connections	Drain
BA.250.20008	120-180	250 mm	12	8.4	6.5-12	160-230	28-32	G1/2	G1/4

## HYDRAULIC THRUSTER 120-180 KGf 8CC MOTOR

**Assets:**

- Maintenance-free synthetic propeller
- Unlimited run time
- Durable hydraulic gearmotor
- Easy access zinc or aluminium anode
- High quality hydraulic components
- Optimised propeller design for maximum efficiency

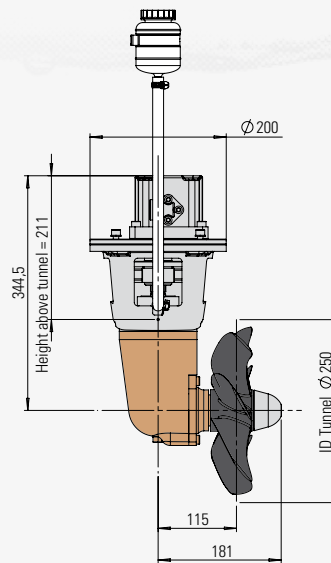

**Optional**



ALFA 20R

BC.020.20020

See **page 79** for the complete range of remote controls.

All thrusters are fitted with a zinc anode as standard. Aluminium anodes are available separately.

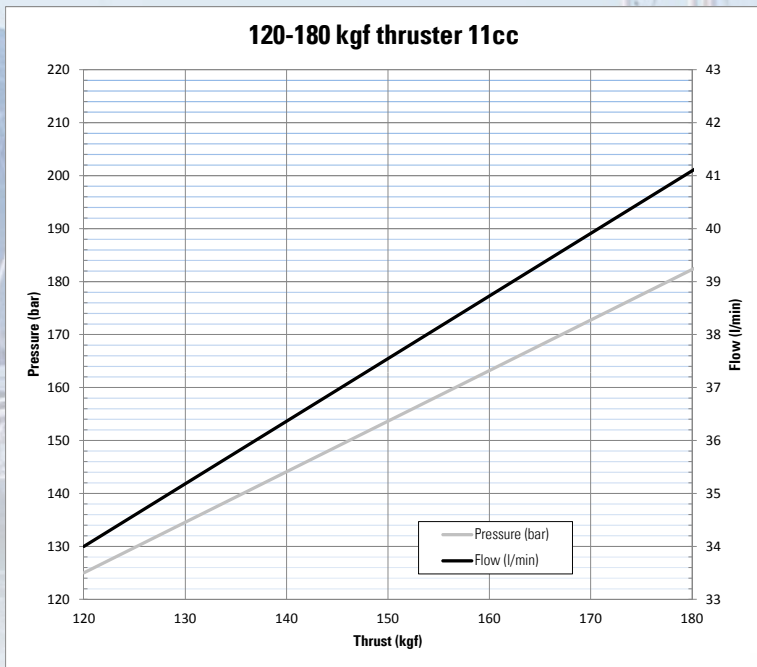

Article code	Thrust (kgf)	Inside diameter of tunnel	Weight (kg)	Hydraulic motor (cc/rev)	Power (kW)	Pressure (bar)	Flowrate (l/min)	Hose connections	Drain
BA.250.20011	120-180	250 mm	12	10.8	6.5-12	125-180	34-41.5	G1/2	G1/4

## HYDRAULIC THRUSTER 120-180 KGF 11CC MOTOR

### Assets:

- Maintenance-free synthetic propeller
- Unlimited run time
- Durable hydraulic gearmotor
- Easy access zinc or aluminium anode
- High quality hydraulic components
- Optimised propeller design for maximum efficiency

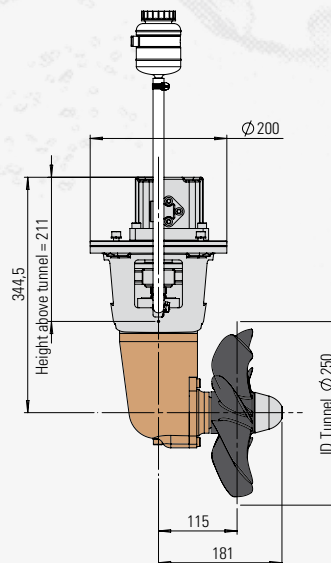

### Optional



See **page 67** for the complete range of thruster panels.

# CRAFTSMAN MARINE THRUSTER PANELS

*Bow and stern thrusters make short handed manoeuvring a breeze.*

**The Craftsman Marine thruster control panels contribute to optimum ease of operation. It is just a push on the button, or to the joystick that triggers a range of complex movements in the most simple way.**

In the case of only a bow thruster, a single panel is used. Dual panels serve the purpose of using both a bow and stern thruster. In that case, each thruster is operated by its

own joystick. The top sides of the panels are waterproof in accordance with the protection classification IP66.

Craftsman Marine thruster control panels are milled from an aluminium plate and anodised to ensure perfect protection against all (marine) weather conditions.



ALFA 20T 81 x 85mm  
BC.010.20002



ALFA 10T 81 x 85mm  
BC.010.20001



ALFA 30T 81 x 136mm  
BC.010.20003

## Thruster panels

All panels work with a very wide voltage input of 10.5-28V DC. The panel has a dip-switch which allows to change factory settings to your own wishes. This makes the panels suitable for all boat types. With the splitter cables a connection to a fly-bridge panel can be made very easily.



1. Stainless bracket
2. Neoprene gasket
3. Coated printed wiring board and rear cover to protect against humidity and salt air
4. Waterproof connectors IP 67. Latch lever lock, to ensure a 100% connection also in case of vibrations.
5. Dip-switch for changing factory settings



Solid anodised aluminium

The following functions are controlled by a microprocessor:

- **Visual and audible alarms**
- **Automatic switch-off of the panel**
  - switch-off after 30 (factory setting), 60 or 120 minutes
  - don't switch-off automatically
- **Time delay of 1 second** when changing the direction switch from/to starboard and portside (factory setting). This function can be disabled.
- **Protection against continuous operation**
  - This function can be disabled, but as extra the LED and audible alarm will indicate that the thruster is continuously enabled for a longer time than 2 minutes
- **Built-in temperature protection**
  - Automatic switch-off of the thruster when the thruster motor temperature is too high. In case of a high temperature it is always possible to use the thruster in a "pulse mode" by releasing the push button or joystick and then activate it again the thruster motor will be enabled for 3 seconds, each time until the temperature is cooled down
- **"Child protection"** to ensure that the panels are not switched on by accident
- **Wire break detection.** Visual alarm if the electrical connection to the thruster relay is broken

## Extension cables for thrusters and anchor windlasses

The Craftsman Marine extension cables are available in lengths of 7m, 10m, 15m and 20m. It is possible to connect different cable lengths together. To protect the electrical installation against moisture, salt, water, dust or dirt, all our cables are fitted with waterproof connectors.



- Waterproof connectors IP67 rubber sealing
- Latch lever lock, to ensure a 100% tight connection, also in case of vibrations.
- With the splitter cable it is very easy to make the connections for fly-bridge panels

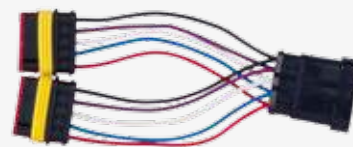

Article codes	
BF.010.20000	Fly-bridge splitter cable
BF.010.20007	Connection cable 7m
BF.010.20010	Connection cable 10m
BF.010.20015	Connection cable 15m
BF.010.20020	Connection cable 20m

## Hydraulic thruster panels NEW

When you are looking for a switch-joystick to control your hydraulic thruster, searchlight or any other application that requires just a simple switch, the Craftsman Marine joystick is the control for you. It matches the looks and feel of the microprocessor controlled thruster panels.

- Maximum switching current 10A
- One step switch joystick



# CRAFTSMAN MARINE HYDRAULIC STEERING SYSTEMS

*Craftsman Marine Hydraulic Steering Systems are easy to use and install, maintenance free and offer steering precision with no muscle required.*

A hydraulic steering system has two main components: the pump at the helm and the cylinder, which moves the rudder. Turning the steering wheel pumps hydraulic fluid through the lines into the cylinder, either extending or retracting the cylinder rod.

Craftsman Marine hydraulic steering systems are standard suitable for twin rudder and/or dual station applications. Contact your local Craftsman Marine representative for assistance with selecting suitable components.

**TIP!**

The strength required to turn the wheel is proportional to the number of turns from lock to lock. The more turns, the less power is required. The number of turns is the ratio between the pump capacity and cylinder volume.

For example an installation with a 20cc pump and a 57cc cylinder requires  $57/20 = 2.85$  turns from lock to lock.

## Steering pumps AVERIS, RETRO & ALEGRO

**Features pumps**

- Ball bearing piston race
- Integral relief valve
- 3/4" conical stainless steel
- Built-in lock valve
- Available in half-flush, front or rear mounting



Article code	Displacement	Pistons	Weight	Max. Pressure	Installation
BK.010.20020	20	5	4.6 kg	50 bar	Half flush
BK.010.20028	28	7	4.8 kg	70 bar	Half flush
BK.010.20034	34	7	4.8 kg	70 bar	Half flush
BK.010.20039	39	7	4.8 kg	70 bar	Half flush
BK.020.20020	20	5	4.6 kg	50 bar	Rear
BK.020.20028	28	7	4.8 kg	70 bar	Rear
BK.020.20034	34	7	4.8 kg	70 bar	Rear
BK.020.20039	39	7	4.8 kg	70 bar	Rear
BK.030.20020	20	5	4.6 kg	50 bar	Front
BK.030.20028	28	7	4.8 kg	70 bar	Front
BK.030.20034	34	7	4.8 kg	70 bar	Front
BK.030.20039	39	7	4.8 kg	70 bar	Front

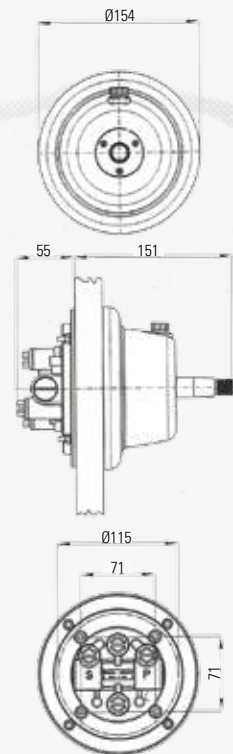

## Steering cylinders MITTO

### Features cylinders

- Balanced: the number of turns lock-to-lock is equal port to starboard or vice-versa
- Patented system
- Fittings 1/4"
- Aluminium anodised liner
- Chromium plated steel stem

CE type examination in conformity with ISO 10592:1995

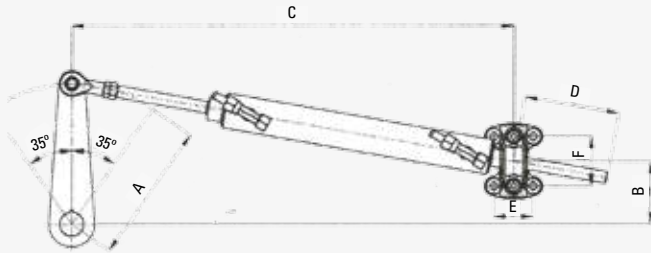

Article code	Diameter mm	Stroke mm	Output Kg	Shank mm	Vol. cc	MT Kgm	A mm	B mm	C mm	D mm	E mm	F mm
BL.010.20025	25	150	264	12	57	34	131	107	458	97	44	56
BL.010.20032	32	178	455	14	116	71	155	127	499	110	44	56
BL.010.20038	38	178	652	16	166	101	155	127	504	112	48	66
BL.010.20040	40	228	701	18	228	140	199	163	590	141	48	66

## Steering wheel TRIVERE

The Craftsman Marine steering wheel is made from durable stainless steel. The rim is fitted with a rubber grip for safety as well as good looks.

- Rubber grip
- 350mm diameter



BN.010.20000

## Accessoires

Craftsman Marine offers a range of accessories to complete your steering system (for hoses see page 110).



### Article codes

BM.020.20000	Hydraulic oil 1 ltr
BM.020.20010	Filling kit
BM.020.20030	T Union 10/8 1/4"
BM.020.20040	Elbow fitting 10/8 1/4"
BM.020.20050	Straight connector fitting 10/8 1/4"
BM.020.20060	Hose connector for nylon hose straight

**PROVIDING RELIABLE PRODUCTS,  
THAT'S WHAT MAKES  
OUR ENGINE RUN!**



*Photo by Goos Watersport (The Netherlands)*

*Boat: Primeur*

*Engine: CM4.42*

**CRAFTED WITH CRAFTSMAN MARINE**



# CRAFTSMAN MARINE STORAGE SOLUTIONS

*"Modern and maintenance free storage tanks for your boat."*

Craftsman Marine tanks make the installation procedure as simple as possible. Without any sawing or drilling you will have the right connections for your specific purpose of the tank.

Just select the correct cover for the required application and all connections and openings are there, in the right place. Even a mounting kit is standard with each set. Since the tanks are made of synthetic material, there is no risk of rust formation.

When in use as a diesel fuel tank, condensation inside is absolutely minimal, compared to a metal fuel tank.

Owing to the large cover, it's easy and it takes little time to inspect and clean the inside of the tank. All Craftsman Marine tanks, whether used as diesel fuel tank or (waste) water tank, are certified for installation in boats that are built in accordance with the directives for pleasure craft 94/25/EC, revised by 2003/44/EC.



NEW



CB.010.25030



CB.010.25020



CB.010.25010

*See page 93 for a complete overview of the tank sensors.*



# CRAFTSMAN MARINE TANK COVERS

*Well thought-out design, hard-wearing materials, no maintenance ...  
everything is readily prepared for care-free use.*



TANK COVER WASTE WATER

CB.010.20010



TANK COVER POTABLE WATER 13MM

CB.010.20020



TANK COVER DIESEL FUEL 8MM

CB.010.20030



TANK COVER BLIND

CB.010.20040

The storage solutions offer you a very smart installation procedure. All our tanks are fitted with large covers and different connections. By simply choosing the correct tank cover for the required application, the right connections are immediately available.

All connections can be rotated 360 degrees and you have the choice between an  $\varnothing 8$  mm connection for the fuel tank,

a  $\varnothing 13$  mm for the fresh water tank or a  $\varnothing 38$  mm for the waste water tank. All covers are available with a level sensor.

For the entire range of the Craftsman Marine fluid level sensors please see page 93.

# CRAFTSMAN MARINE STORAGE TANKS

*Craftsman Marine tanks are made of synthetic material, which makes them extremely strong and virtually indestructible.*

*By virtue of the excellent insulating properties, condensation in the tank is much less than in the case of steel or another metal and there is not the slightest risk of rust formation.*

*Easy cleaning of the tanks is ensured by the large inspection cover.*



*For deckfillers  
see page 112.*

	TANK 33LTR	TANK 50LTR	TANK 65LTR	TANK 80LTR
<b>Article code:</b>	CA.010.20033	CA.010.20050	CA.010.20065	CA.010.20080
<b>Net volume:</b>	33 liter	50 liter	65 liter	80 liter
<b>Filling hose connection:</b>	ø38	ø38	ø38	ø38
<b>Breather connection:</b>	ø19	ø19	ø19	ø19
<b>Weight:</b>	4.1 kg	6.5 kg	7.3 kg	7.8 kg
<b>Outside dimensions:</b>	420 x 380 x 250 mm	600 x 380 x 250 mm	800 x 380 x 250 mm	1000 x 380 x 250 mm

## Smell absorbers

Nasty smells from the diesel fuel tank or from the waste water tank may well spoil your boating pleasure.

The solution is simple: Each tank requires a ventilation (or: breather) opening. Just fit a Craftsman Marine smell absorber into the breather line, before it leaves the boat. No more bad smells in the cockpit and no more angry looks from the neighbours.

The filters are provided with an active carbon filter element. Naturally these are separately available and it is recommended to replace them before the start of the new boating season. The old elements can be disposed of in the regular garbage.

The filters are available for hose diameters of **ø16, ø19 and ø25 mm** (see page 110 for the hoses).

**NEW: NOW ALSO AVAILABLE IN Ø 16 mm**



Active carbon filter



REPLACEMENT FILTER

CF.010.90001

Article code	Description	Hose connections
CF.010.20016	Smell absorber 16mm waste water	16mm
CF.010.20019	Smell absorber 19mm waste water	19mm
CF.010.20025	Smell absorber 25mm waste water	25mm
CF.020.20016	Smell absorber 16mm diesel fuel	16mm
CF.020.20019	Smell absorber 19mm diesel fuel	19mm
CF.020.20025	Smell absorber 19mm diesel fuel	25mm
CF.010.90001	Spare element smell absorber	





# CRAFTSMAN MARINE ELECTRONICS

*"Attention to every detail."*

Electronics are a basic necessity for modern vessels these days. Even the smallest boats have some kind of electrical system. For boat owners rigged or low quality electronics can be an inconvenience. High quality electronics are essential to keep your vessel operational, to keep you safe and ready for any kind of weather.

Electrical equipment on vessels must comply with relevant standards and regulations, must stand the test of time and must be protected with the right conformal coating to offer protection against all possible environmental conditions such as humidity and salty air.

All Craftsman Marine electrical components are developed with the greatest care. Every component and application is thoroughly tested and investigated on a number of quality requirements.

Craftsman Marine offers you a wide variety of electronic components such as batteries, fuse holders, main battery switches, cables, cable terminals and much more. Because we believe in giving attention to every detail, you can be sure all our electronic components are made of quality materials and are developed according to the latest marine standards.



# NO MATTER WHAT BOAT YOU HAVE, CRAFTSMAN MARINE IS THERE FOR YOU!

*Photo by Joost Zwiers  
Oranje Sluis, Amsterdam (The Netherlands)*

## Wireless remote

The new wireless remote control by Craftsman Marine is one of a kind in pleasure craft. It utilises the 2.4 GHz ISM band and can be used for a multitude of devices. It gives you control over the operations of your choice.

Five different layouts are available for you to choose from, for your bowthruster, stern thruster or windlass. The Craftsman Marine remote control is a perfect addition to your thruster panel to give you even more flexibility. It is IP67 waterproof rated and floats when dropped overboard! Controlling your thruster or windlass has never been more easy.



## How it works

The wireless remote uses a constant changing frequency in the 2.4GHz range to get a stable communication without interference from engine-noise, WiFi equipment or any other wireless equipment.

Multiple transmitters can be used with a single receiver. The transmitters and receivers use a unique 32 bit code, named Electronic Serial Number (ESN). After pairing the transmitter with the receiver it is impossible to get interference from your neighbour with the same system. The range exceeds 20 meters. The transmitter uses a replaceable button cell that will last for several years with regular use.

Specifications	
Operating voltage receiver	8-30V DC
IP rating transmitter	IP67
Dimensions transmitter	40 x 120 x 15mm
Range	> 20m
Battery life transmitter	> 1 year
Approvals	CE and ETSI (Europe) IC and FCC (USA)



## Fuse holder

Developed in-house and offers many advantages. During the development stage, extensive research is done in regard to application area, power range, type of material, easy installation and use of the fuse holder. With the Craftsman Marine fuse holder you can rely on a quick and easy installation and an excellent performance.



Article codes	
DD.030.20000	Fuse holder incl. cover, 500A
DD.040.20040	ANL fuse 40A
DD.040.20050	ANL fuse 50A
DD.040.20063	ANL fuse 63A
DD.040.20080	ANL fuse 80A
DD.040.20100	ANL fuse 100A
DD.040.20125	ANL fuse 125A
DD.040.20160	ANL fuse 160A
DD.040.20200	ANL fuse 200A
DD.040.20250	ANL fuse 250A
DD.040.20300	ANL fuse 300A
DD.040.20355	ANL fuse 355A
DD.040.20425	ANL fuse 425A
DD.040.20500	ANL fuse 500A
DD.045.20000	Copper bus bar 500A

Specifications of Fuse	
<b>Maximum voltage:</b>	80V DC
<b>Type of Fuse:</b>	ANL "slow-blow", DIN 43560/1 Closed housing with glass inspection window
<b>Terminals:</b>	For M10 bolts
<b>Material:</b>	40A - 80A: zinc 100A - 500A: nickel plated copper

Specifications of Fuse Holder	
<b>Maximum voltage:</b>	48V DC
<b>Type of Fuse:</b>	ANL "slow-blow", maximum 500A
<b>Terminals:</b>	M10, bolts and nuts Maximum torque 11Nm
<b>Dimension:</b>	125 x 35 x 42mm

When choosing the fuse amperage, please observe that the fuse is of the "slow-blow" type.

### Example:

Fuse amperage = 80A  
Load = 120A = 150%: time to trip is longer than 1 hour  
Load = 200A = 250%: time to trip is between 0.8-10 seconds

### Trip Characteristics:

Load	Trip time (blow-out time)
150%	Longer than 1 hour
180%	Less than 1 hour
220%	Maximum 60 seconds
250%	0.8-10 seconds
400%	0.2-2 seconds



## Fuse holder

1. **Brass terminals:**
  - low voltage drop and therefore low heat production
  - resistant against humidity and salty air
2. **Multiple installation directions** for both cable connections. This will give you full flexibility for routing your cable installation.
3. Cover with easy **break-out plates** for each cable direction
4. Cover fastens by means of a **click system**
5. **Inspection window** to check the fuse

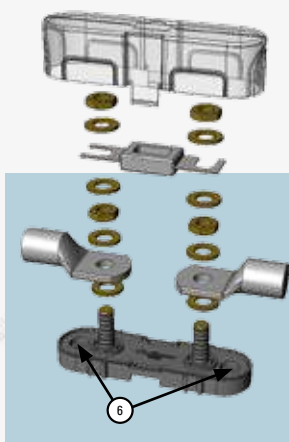

6. **Stable and reliable installation**, owing to the installation holes on the outer side, which prevent rotation of the base plate when tightening the connection terminals.

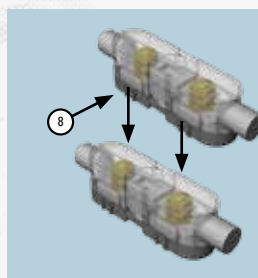

8. **Stacking of fuse holders**, thanks to slide system in the sides.

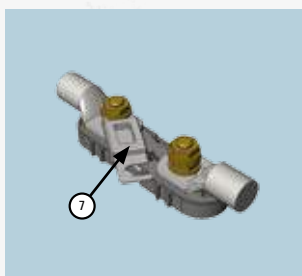

7. Quick and easy **replacement of the fuse**, without removing the nuts and the cables.

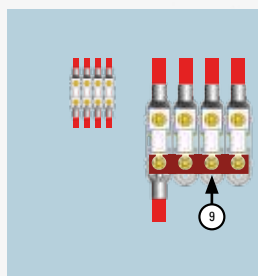

9. **Bus bar**, simplifies your installation and lowers the cost thereof.

## Battery main switches

A battery main switch by Craftsman Marine is a “must” for each electrical installation on board. With the use of one of these three models, even the most complicated electrical installation is perfectly secured. All components of these switches have been extensively tested, giving much attention to the materials to be used, such as the massive copper switch contacts and the sturdy M10 connections, which enable a high peak load.

Duplicate keys for the 100A and 250A models are available.



- **Copper switch contacts** and connection bolts, brass nuts:
  - low voltage drop and therefore a minimum of heat development
  - accepts high peak loads; see table with specifications
  - resistant against humid surroundings and salty air
- **Rubber dust cover** for the 100A and 250A models. Protects the innards of the switch when the key is removed.
- **Removable key** in the “off” position for the 100A en 250A models. **Additional keys are available** for these models. A dust cover is integrated in the key.
- Extra **thick base nut**. Easily to be blocked by means of an open-ended spanner. This will prevent the connection bolts from turning when the outer nuts are being secured.

	Battery main switch 100A	Battery main switch 250A	Battery main switch 600A
<b>Load</b>			
<b>continuous</b>	100A	250A	600A
<b>5 seconds</b>	500A	2500A	4000A
<b>Auxiliary contact</b>	-	-	5A, single pole
<b>Maximum voltage</b>	24V DC	24V DC	24V DC
<b>Removable key</b>	yes	yes	no
<b>Additional key</b>	yes	yes	no
<b>Type of contact</b>	Single pole, 2 positions, “on” and “off”.	Single pole, 2 positions, “on” and “off”.	Single pole, 2 positions, “on” and “off”.
<b>Battery connections</b>	M10. Copper bolts, brass nuts Maximum torque 11Nm	M10. Copper bolts, brass nuts Maximum torque 11Nm	M10. Copper bolts, brass nuts Maximum torque 11Nm
<b>Protection</b>	IP65	IP65	IP65

## Battery cables

- Very flexible cables
- Double isolated (size 16mm<sup>2</sup> till 120mm<sup>2</sup>)
- Oil resistant
- RCD 2003/44/EC and ISO1013300:2000 certified

Article codes			
<b>DD.070.22063</b>	Twinflex cable 2 x 6mm <sup>2</sup>	<b>DD.070.20501</b>	Battery cable 50mm <sup>2</sup> black
<b>DD.070.22103</b>	Twinflex cable 2 x 10mm <sup>2</sup>	<b>DD.070.20502</b>	Battery cable 50mm <sup>2</sup> red
<b>DD.070.20161</b>	Battery cable 16mm <sup>2</sup> black	<b>DD.070.20701</b>	Battery cable 70mm <sup>2</sup> black
<b>DD.070.20162</b>	Battery cable 16mm <sup>2</sup> red	<b>DD.070.20702</b>	Battery cable 70mm <sup>2</sup> red
<b>DD.070.20251</b>	Battery cable 25mm <sup>2</sup> black	<b>DD.070.20951</b>	Battery cable 95mm <sup>2</sup> black
<b>DD.070.20252</b>	Battery cable 25mm <sup>2</sup> red	<b>DD.070.20952</b>	Battery cable 95mm <sup>2</sup> red
<b>DD.070.20351</b>	Battery cable 35mm <sup>2</sup> black	<b>DD.070.21201</b>	Battery cable 120mm <sup>2</sup> black
<b>DD.070.20352</b>	Battery cable 35mm <sup>2</sup> red	<b>DD.070.21202</b>	Battery cable 120mm <sup>2</sup> red



## Batteries

Craftsman Marine batteries are designed for use in pleasure craft or any comparable application.

- VRLA (valve regulated lead acid), no filling with water required
- Maintenance free and completely sealed
- Lead-calcium battery plates
- Low self-discharge
- Resistance against vibrations and shocks
- Deep cycle (140Ah, 180Ah, and 230Ah)
- Centered cell connections improve the distribution of the charging current



Type	Product code	Voltage	Capacity C20	Cold Cranking amps CCA (EN)	Weight (kg)	Dimension WxDxH (mm)
VMF60L	DE.010.20060	12V	60Ah	470A	14.2	242 x 175 x 175
VMF70L	DE.010.20070	12V	70Ah	680A	16.7	278 x 175 x 175
VMF95L	DE.010.20095	12V	95Ah	720A	21.3	353 x 175 x 190
VMF105L	DE.010.20105	12V	105Ah	680A	22.6	330 x 172 x 242
VMF140L	DE.010.20140	12V	140Ah	800A	39.0	513 x 189 x 223
VMF180L	DE.010.20180	12V	180Ah	1000A	46.3	513 x 189 x 223
VMF230L	DE.010.20230	12V	230Ah	1150A	59.5	518 x 276 x 242

# PERFECT ELECTRICAL CONDUCTION FOR LOW VOLTAGE DROP!

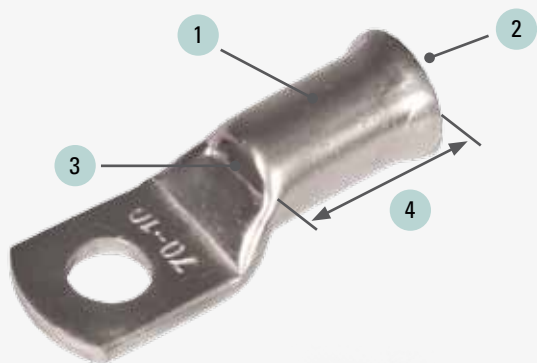

## Cable terminals

- Massive copper, tin plated** by means of electrolysis:
  - minimal voltage drop and heat generation
  - resistant against humid surroundings and salty air
- Sleeve provided with a **guide**
  - easy cable entry owing to the enlarged opening
- Inspection opening**
  - To verify that the cable is entirely inserted
- Extra long sleeve**
  - Provides for a larger contact surface and therefore a lower transfer resistance, minimal voltage drop and minimal heat generation

Article codes			
<b>DD.010.20606</b>	Cable terminal 06mm <sup>2</sup> M6	<b>DD.010.23510</b>	Cable terminal 35mm <sup>2</sup> M10
<b>DD.010.20608</b>	Cable terminal 06mm <sup>2</sup> M8	<b>DD.010.25008</b>	Cable terminal 50mm <sup>2</sup> M8
<b>DD.010.21006</b>	Cable terminal 10mm <sup>2</sup> M6	<b>DD.010.25010</b>	Cable terminal 50mm <sup>2</sup> M10
<b>DD.010.21008</b>	Cable terminal 10mm <sup>2</sup> M8	<b>DD.010.27008</b>	Cable terminal 70mm <sup>2</sup> M8
<b>DD.010.21010</b>	Cable terminal 10mm <sup>2</sup> M10	<b>DD.010.27010</b>	Cable terminal 70mm <sup>2</sup> M10
<b>DD.010.22508</b>	Cable terminal 25mm <sup>2</sup> M8	<b>DD.010.29508</b>	Cable terminal 95mm <sup>2</sup> M8
<b>DD.010.22510</b>	Cable terminal 25mm <sup>2</sup> M10	<b>DD.010.29510</b>	Cable terminal 95mm <sup>2</sup> M10
<b>DD.010.23506</b>	Cable terminal 35mm <sup>2</sup> M6	<b>DD.010.21201</b>	Cable terminal 120mm <sup>2</sup> M10
<b>DD.010.23508</b>	Cable terminal 35mm <sup>2</sup> M8	<b>DD.010.21501</b>	Cable terminal 150mm <sup>2</sup> M10

## Cable and battery terminals

These Craftsman Marine terminals, ostensibly a minor item, have attained full focus from our designing engineers. As said, it seems to be a simple product, but it is in actual fact a very important part of your electrical installation.

These connections form part of a proper electrical conduction. A bad connection may cause a too great voltage drop, generate too much heat, resulting in molten cables or even fire on board. It is therefore of utmost importance to provide your electrical installation with the right terminals.



DD.060.21010

- Full-brass battery terminal including the M10 integrated bolt, tin plated
- Supplied as a set of plus and minus terminals
- For cables up to 150mm<sup>2</sup>

- Full-brass battery terminal tin plated
- Supplied as a set of plus and minus terminals
- For cables from 10 to 70mm<sup>2</sup>



DD.060.22010



DD.060.23010

- Full-brass battery terminal tin plated
- Supplied as a set of plus and minus terminals
- For cables from 10 to 70mm<sup>2</sup>
- Two cable inputs

A dramatic sunset over a body of water. The sky is filled with large, dark clouds, some of which are illuminated from below by the setting sun, creating a vibrant orange and yellow glow. The sun's light reflects on the water's surface. In the foreground, a lighthouse stands on a small pier to the left, and a large, multi-story white building with a dark roof is visible on the right. The overall mood is serene and powerful.

**PASSION FOR PRODUCTS THAT  
STAND THE TEST OF TIME AND  
ALL WEATHER CONDITIONS!**





# GAUGES AND ACCESSORIES

*Highly tested quality components, for endurance and longevity.*

Gauges are essential to give the right information at the right time. And yes, even gauges should look good and act accordingly. Designing and developing gauges and indicators goes beyond the mere aesthetic.

First and foremost, gauges need to be resistant against the worst environmental conditions such as salty air, high humidity, variations in temperature, vibrations and UV-light. Second, gauges must be easy to install and must be finished with the appropriate coatings.

Craftsman Marine offers a wide variety of gauges for any marine application. All our gauges are tested in certified laboratories with high quality test equipment. This guarantees the endurance and longevity of these products as well as their safety and functionality.



*\* Black or white standard supply with the gauge.*

CHROME BEZEL FOR 52mm GAUGE

DB.010.20052

CHROME BEZEL FOR 85mm GAUGE

DB.010.20085



#### General features for all Craftsman Marine gauges

- Double lens \*, no condensation. Lens is replaceable. IP67 protection on the frontside
- Panel mount or flush
- Bezel easy changeable  
Available in black, white or chrome
- Backlight through transparent dial  
Automatic dimmer option with engine panels
- Fluorescent pointer for perfect readings in any lighting condition
- Easy installation with supplied bracket
- Standard 6.3 blade electrical connections

\* Optional for the rudder gauge.



**Tachometers**

- Very accurate and stable indication due to the microprocessor controlled stepper motor
- LCD with hour counter and backlight. Hour counter starts counting when the speed of the engine is above 400rpm and is indicated with an hourglass icon in the display
- Diameter 85mm
- Operating voltage 10.5 – 28V DC
- Suitable for input signals from alternator (W signal) or an inductive pickup sensor (0.5 – 399 pulses/revolution)
- Easy calibration with a micro push button on the backside

**Oil pressure switch/sensor**

- Switching point 0.5 bar
- R 1/8 thread



DB.020.20001



**Oil pressure gauges**

- Operating voltage 12V DC
- Pressure indication 0-10 bar and 0-145 psi
- Input resistance range:  
0 ohm = 0 bar, 52 ohm = 2 bar  
88 ohm = 4 bar, 124 ohm = 6 bar, 180 ohm = 10 bar
- Diameter 52mm
- Built-in damping for smooth pointer movement

**Temperature switch/sensor**

- Switching point 105 °C
- M16x1.5 thread



DB.020.20002



**Temperature gauges**

- Operating voltage 12V DC
- Temperature indication 40-120 °C and 105-250 °F
- Input resistance range:  
287 ohm = 40 °C, 134 ohm = 60 °C  
69 ohm = 80 °C, 38 ohm = 100 °C, 23 ohm = 120 °C
- Diameter 52mm
- Built-in damping for smooth pointer movement

**Temperature sensor**

- M16x1.5 thread



DB.020.20003



**Voltmeters**

- Voltage indication 8-16V DC
- Diameter 52mm
- Built-in damping for smooth pointer movement

**Waste-water gauges**

- Operating voltage 12V DC or 24V DC
- Input resistance range: 0 ohm = E, 100 ohm = ½, 180 ohm = F
- Diameter 52mm
- Built-in damping for smooth pointer movement



**Fuel gauges**

- Operating voltage 12V DC or 24V DC
- Input resistance range: 0 ohm = E, 100 ohm = ½, 180 ohm = F
- Diameter 52mm
- Built-in damping for smooth pointer movement



**Water gauges**

- Operating voltage 12V DC or 24V DC
- Input resistance range: 0 ohm = E, 100 ohm = ½, 180 ohm = F
- Diameter 52mm
- Built-in damping for smooth pointer movement



**Rudder gauges**

- Operating voltage 12V DC and 24V DC
- Accurate indication due to stepper motor control
- Input resistance range: 0-190 ohm
- LED background light in 2 colors yellow and red
- Diameter 52mm
- Single glass with anti-fog coating, double glass is optional



**Rudder sensor**

- 0-190 ohm



**Double glass**

DB.010.90003

## Backlight dimmer module

With the Craftsman Marine dimmer module manual dimming of the backlight is no longer required. This microprocessor controlled dimmer module will automatically dim the backlight very smoothly when it becomes dark. At daylight it will increase the intensity of the backlight.



with automatic backlight dimmer module

Just plug-in the module on the rear side of the engine panel:

- Maximum load 5A
- Printed wiring board with conformal coating for environmental protection.



AB.020.20002

\* Automatic dimming of the backlight

Solid anodised aluminium



DC.010.20000

\* Supplied without gauges



## Instrument panel for 52mm gauge

- Machined out of a solid plate of aluminium. Anodised to protect against weather influences.
- Suitable for two 52mm gauges
- Supplied with:
  - gasket
  - brackets to fit the gauges
  - 4 stainless steel screws
  - protection cover

## Tank sensors

The Craftsman Marine capacitive tank sensor is based on electronic detection without any moving parts. This ensures a long lifetime as there is no mechanical wear. The sensor can be used with the Craftsman Marine tank gauge or any other gauge with the appropriate resistance input.



CG.010.20020

### Capacitive tank sensor

The capacitive tank sensor can only be used for measuring **diesel fuel**.

- Maximum measuring depth of 20cm
- Resistance output from tank empty to full in variable steps: 10ohm - 180ohm
- Voltage 10.5 – 28VDC
- Threading M27
- Temperature range -10 up to 70° C

## Reed switch tank sensor NEW

The reed switch sensors can be used for measuring diesel, potable water and waste water. All sensors use a stainless steel pipe and have a SAE5 mounting flange. The maximum measuring depth is 20cm. The resistance output from tank empty to tank full is in seven steps from 10 to 180 ohm.



TANK COVER DIESEL  
FUEL INCL. SENSOR

CB.010.25030



TANK COVER POTABLE  
WATER INCL. SENSOR

CB.010.25020



TANK COVER WASTE  
WATER INCL. SENSOR

CB.010.25010

- Measures the tank content from ¼ of the tank depth till maximum level
- Stainless steel filter, possible to disassemble for cleaning purpose.

# CRAFTSMAN MARINE PORTHOLES & HATCHES

*Made from high quality seawater resistant anodised aluminium, stainless steel and fiber reinforced synthetic materials, our portholes and hatches are built to last. Designed to keep the weather out and the light in.*

Whether you are looking to fit out your new boat or need to replace your existing portholes and hatches, the finish of our products will certainly live up to your expectations. Frames are polished by hand before anodising, to remove the smallest impurities from the material.

Easy installation, replaceable sealings and full support for spare parts guarantee long lasting service. Smoke grey acrylic is used in all portholes and hatches to ensure your privacy inside the boat but still maintain sufficient light transmission.

All hatches can be opened from the inside and outside and can be locked from the inside.

To keep your boat well ventilated while you are away, the hatches can even be locked in a ventilation position. Smooth finish of the inside of the frame ensures easy access for crew or equipment. Mosquito screens are available for all hatches and even standard supply for all portholes.

CE certification comes standard with all portholes and hatches.



# FOR THE TOUGHEST CONDITIONS

*Photo by Joost Zwiers*

*Boat: Miles, Jeanneau Sun Legende 41*

*Deck Hatches and Anchor Windlass Craftsman Marine*

**SIRIUS** CE CLASS  
AREA II A

Our top notch off shore hatch for the toughest conditions. Hand-polished aluminum frame finished to a high standard. Stainless steel struts to keep the hatch opened in any position from 0 to 110°. Handles with integrated locking system and softgrip for effortless handling. All SIRIUS hatches can be opened from outside when not locked. Easy when changing sails in bad weather or when used as an escape hatch. Only rustproof materials are used. Mosquito screens are optional.

- Tough design with frame
- CE Area IIa
- Lockable ventilation position

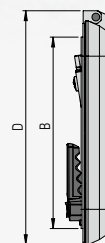
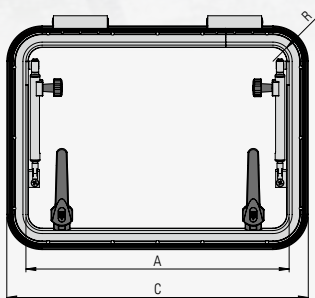

A mosquito screen is available as an option.

Model	Overall dimensions (Cx D)	Cutout size (Ax B)	Corner radius	Mosquito screen
FB.010.20010	254x254	200x200	32mm	FB.010.21010
FB.010.20020	394x249	340x195	32mm	FB.010.21020
FB.010.20030	504x374	450x320	32mm	FB.010.21030
FB.010.20035	504x374	450x320	55mm	FB.010.21035
FB.010.20040	554x424	500x370	32mm	FB.010.21040
FB.010.20045	554x424	500x370	55mm	FB.010.21045
FB.010.20050	464x464	410x410	32mm	FB.010.21050
FB.010.20055	464x464	410x410	55mm	FB.010.21055
FB.010.20060	554x554	500x500	32mm	FB.010.21060
FB.010.20065	554x554	500x500	55mm	FB.010.21065
FB.010.20070	674x674	620x620	32mm	FB.010.21070
FB.010.20075	674x674	620x620	55mm	FB.010.21075
FB.010.20080	754x754	700x700	32mm	FB.010.21080
FB.010.20085	754x754	700x700	55mm	FB.010.21085
FB.010.20090	854x854	800x800	32mm	FB.010.21090
FB.010.20095	854x854	800x800	55mm	FB.010.21095

Other sizes available on request.

**AQUILA** CE CLASS  
AREA II A

Our entry model but with the same excellent finish as all other Craftsman Marine products. Low profile design hatch with friction hinges for easy one hand operation. 12mm smoke grey acrylic assures that even when you step onto the hatch it won't break. Standard supplied with installation manual and drill pattern. All AQUILA hatches open 180°.



- CE Area IIa
- Easy operation
- For wall thickness 4-22mm
- Lockable ventilation position

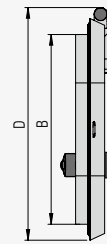
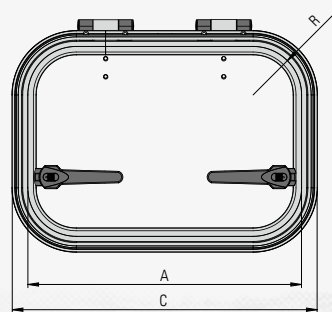

A mosquito screen is available as an option.

Model	Overall dimensions (Cx D)	Cutout size (AxB)	Corner radius	Mosquito screen
FB.020.20005	279x279 mm	230x230 mm	75 mm	FB.020.21005
FB.020.20010	349x279 mm	300x230 mm	75 mm	FB.020.21010
FB.020.20020	389x259 mm	340x210 mm	75 mm	FB.020.21020
FB.020.20030	423x423 mm	374x374 mm	75 mm	FB.020.21030
FB.020.20040	473x343 mm	424x294 mm	75 mm	FB.020.21040
FB.020.20050	473x473 mm	424x424 mm	75 mm	FB.020.21050
FB.020.20060	520x520 mm	471x471 mm	75 mm	FB.020.21060
FB.020.20070	624x624 mm	575x575 mm	75 mm	FB.020.21070

Other sizes available on request.

# OMEGA STANDARD

CE CLASS AREA II A

Standard supplied with mosquito screen and hand-polished anodised finish. Easy operation and fixed opening positions. All portholes are supplied with inner frames for easy mounting and a professional finish. Small knobs for closing the ports assure optimum visibility. Good water draining because of the angled outside frame design.



10mm acrylic



BLACK ANODISED

FA.015.25XXX



DEADLIGHTS

FA.015.20XXX



FA.010.20XXX



FA.010.25XXX

- CE Area Ila
- Easy operation
- For wall thickness 4-22mm
- Good water draining

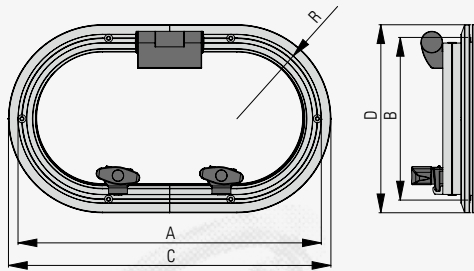

A mosquito screen is included.

Model	Overall dimensions (Cx D)	Cutout size (Ax B)	Corner radius
FA.010.20010	246 x 150 mm	222 x 126 mm	63 mm
FA.010.20020	296 x 175 mm	272 x 151 mm	75.5 mm
FA.010.20030	346 x 203 mm	322 x 179 mm	89.5 mm
FA.010.20040	364 x 150 mm	340 x 126 mm	63 mm
FA.010.20050	392 x 226 mm	368 x 202 mm	101 mm
FA.010.20060	504 x 257 mm	480 x 233 mm	116.5 mm
FA.010.20070	624 x 203 mm	600 x 179 mm	89.5 mm
FA.015.20010 *	246 x 150 mm	222 x 126 mm	63 mm
FA.015.20020 *	296 x 175 mm	272 x 151 mm	75.5 mm
FA.015.20030 *	346 x 203 mm	322 x 179 mm	89.5 mm
FA.015.20040 *	364 x 150 mm	340 x 126 mm	63 mm

Black anodised portholes and other sizes available on request.

\* Deadlights (non-opening)

# OMEGA RECTANGULAR

CE CLASS AREA II A

Standard supplied with mosquito screen and hand-polished anodised finish. Easy operation and fixed opening positions. All portholes are supplied with inner frames for easy mounting and a professional finish. Small knobs for closing the port assure optimum visibility. Good water draining because of the angled outside frame design.



- CE Area IIa
- Easy operation
- Good water draining
- For wall thickness 4-22mm

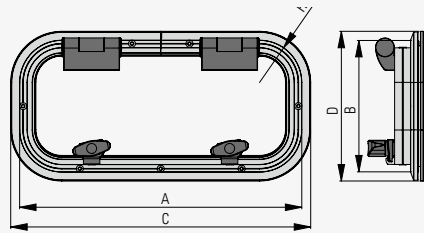

A mosquito screen is included.

Model	Overall dimensions (Cx D)	Cutout size (Ax B)	Corner radius
FA.020.20080	300 x 163 mm	279 x 142 mm	51
FA.020.20090	350 x 173 mm	329 x 152 mm	51
FA.020.20100	365 x 182 mm	343 x 160 mm	51
FA.020.20110	365 x 198 mm	343 x 176 mm	51
FA.020.20120	399 x 190 mm	377 x 168 mm	51
FA.020.20130	399 x 234 mm	377 x 212 mm	51
FA.020.20140	450 x 273 mm	429 x 252 mm	51
FA.020.20150	496 x 276 mm	475 x 255 mm	51
FA.020.20160	651 x 201 mm	630 x 180 mm	51
FA.025.20080 *	300 x 163 mm	279 x 142 mm	51
FA.025.20090 *	350 x 173 mm	329 x 152 mm	51
FA.025.20100 *	365 x 182 mm	343 x 160 mm	51
FA.025.20110 *	365 x 198 mm	343 x 176 mm	51
FA.025.20120 *	399 x 190 mm	377 x 168 mm	51

Black anodised portholes and other sizes available on request.

\* Deadlights (non-opening)

# OMEGA ROUND

CE CLASS AREA II A

Standard supplied with mosquito screen and hand-polished anodised finish. Easy operation and fixed opening positions. All portholes are supplied with inner frames for easy mounting and a professional finish. Small knobs for closing the port assure optimum visibility. Good water draining because of the angled outside frame design.

**new**

**new**



BLACK ANODISED

DEADLIGHTS

FA.030.25xxx

FA.035.20xxx



FA.030.20xxx



DEADLIGHTS

FA.035.25xxx

- CE Area IIa
- Easy operation
- For wall thickness 4-22mm
- Good water draining

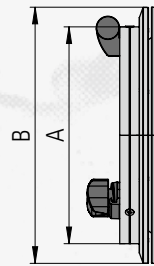
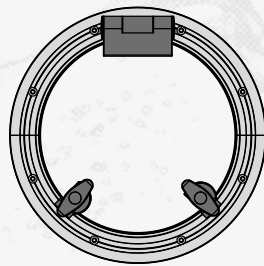

A mosquito screen is included.

Model	Overall dimensions (B)	Cutout size (A)	Radius
FA.030.20170	200 mm	179 mm	89.5 mm
FA.030.20180	223 mm	202 mm	101 mm
FA.030.20190	254 mm	233 mm	116.5 mm
FA.030.20200	374 mm	353 mm	176.5 mm
FA.035.20170 *	200 mm	179 mm	89.5 mm
FA.035.20180 *	223 mm	202 mm	101 mm

Black anodised portholes and other sizes available on request.

\* Deadlights (non-opening)

# CRAFTSMAN MARINE ANCHOR WINDLASS

*"Easy anchoring when and where you desire ."*



Enjoying your boat is not only sailing with it. It's also relaxing. What can beat lying at anchor in the spot you choose, for the time you like with the people you like? On board at anchor is like living on your private island and you can do what you like. Take a swim in clear water, dive or simply relax and read a book. Watch the stars at night and wake up with astonishing sunrise!

But what is holding you off? The hassle with the chain, the mud, the dirty hands, the broken back? Lifting your anchor when it's 30 degrees Celsius is not something to look out for. With a Craftsman Marine windlass it is all the push of a button away. When your helm position has a clear view of the windlass, it's even easy to recover the anchor single handed, while standing at the helm.

The anchor not holding very well? With the push of a button, you bring it back up and try it a few metres further on, without breaking a sweat! And for a good night's rest, you simply pay out a little extra chain because no extra effort is needed to recover it.

**Windlass selection**

Probably the first item to determine the size of the windlass is the chain used. When retrofitting, there is already an anchor rode on board that determines the gypsy to be used. With a new fitting, this doesn't apply. Secondly, the size of the windlass is depending on the size and weight of the boat. Chain size is determined by the size of the boat and the type of cruising you do. Craftsman Marine windlasses can be fitted with gypsies for several chain sizes to make a balanced combination for your boat. Only calibrated chains can be used in the windlasses.

The weight of the chain and anchor determine the power required. Anchor windlass specifications contain the working load (getting in the chain) and a maximum pull (breaking out the anchor). When you anchor in shallow water, you might only have to lift 3-4 metres of chain off the seabed. But when you plan to anchor in deeper waters, the working load will increase. When properly used, the required windlass is not that bulky and will be cheaper to purchase and install. You can consider the windlass as a direct replacement of your body. By hand you will not pull the boat towards the anchor. Instead you will use the power of the engine to move towards the anchor and just lift the anchor chain off the bottom. Breaking out the anchor can also be done by reversing the boat. Installing a smaller windlass means less space needed, thinner cables, smaller fuses, and a reduced load on your batteries.



Stainless steel 316

**Windlass types**

Craftsman Marine offers vertical windlass designs to minimise deck clutter. The electric motor and gearbox are installed below decks and are IP66 rated. The chain runs 180 degrees around the gypsy resulting in unmatched resistance against slippage. In comparison, a horizontal windlass design will have all its components above deck level, making it bulky and bringing more weight high above the waterline. The chain only runs 90 degrees around the gypsy, making it more prone to slippage than a vertical windlass design.

**Capstan**

A windlass with capstan can be useful for handling a "rope only" secondary anchor rode, for lifting the dingy or taking in a mooring line. The capstan must never be used to haul a person up the mast. With the use of a chain stopper on the primary anchor rode, the secondary "rope only" anchor rode can be retrieved with the chain of the all chain anchor rode still in the windlass.

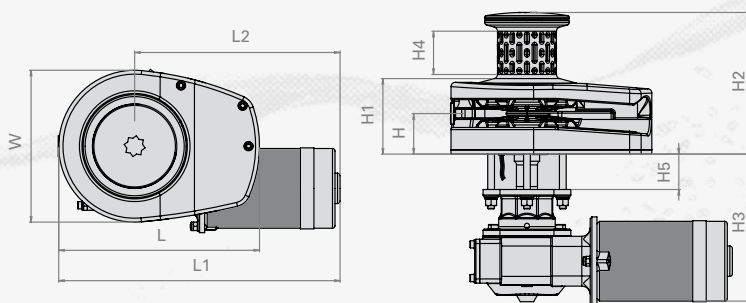

	H	H1	H2*	H3	H4	H5	L	L1	L2	W
<b>400W</b>	44	77.5	138	150	36.5	25	182.5	292.5	225	135
<b>700W</b>	48	91	168	174	52	42	238	333.5	243.5	180
<b>1000W</b>	48	91	168	184	52	42	238	338	248	180

\* Version with capstan.

## Anchor windlass

In the table below you can find the corresponding article codes and specifications for each windlass type. A version with a capstan is available for every type. Our windlass has a freefall function to drop the chain quickly when necessary. It can handle chain and rope. Craftsman Marine can also supply the DIN766 calibrated chain.



	400W / 12V	700W / 12V	1000W / 12V	1000W / 24V
<b>Work load</b>	100kg	115kg	145kg	145kg
<b>Maximum pull</b>	280kg	450kg	800kg	800kg
<b>Maximum chain speed</b>	27m/min	30m/min	30m/min	30m/min
<b>Pulling Chain speed @ workload</b>	15m/min	18m/min	16m/min	16m/min
<b>Current @ workload</b>	105A	140A	110A	50A
<b>Weight</b>	10.7kg	13.5kg	16kg	16kg
<b>Chain</b>	6mm	8 or 10mm	8 or 10mm	8 or 10mm
<b>Rope</b>	8-10mm	14-16mm	14-16mm	14-16mm
<b>6mm gypsy</b>	FC.010.20006			
<b>6mm gypsy with capstan</b>	FC.010.20506			
<b>8mm gypsy</b>		FC.020.20008	FC.030.25008	FC.030.26008
<b>8mm gypsy with capstan</b>		FC.020.20508	FC.030.25508	FC.030.26508
<b>10mm gypsy</b>		FC.020.20010	FC.030.25010	FC.030.26010
<b>10mm gypsy with capstan</b>		FC.020.20510	FC.030.25510	FC.030.26510

### Standard supply

Every windlass comes with most of the required components needed for installation. A base gasket seal between the windlass and deck, two circuit breakers (automatic), a heavy duty relays complete with cable loom, a winch handle to control the clutch and of course a drill pattern. Cables, control panel and tools are not included.





### TIPS FOR SAFE USE

- Always have the engine running when using your windlass. When running the engine, the alternator will keep the battery topped up and the voltage higher
- Always keep your hands, clothing or jewelry clear of the windlass
- Pick your spot to drop your anchor and make a full circle around to check water depth
- Slowly lower your anchor and pay out chain or rope at the same pace as the boat is drifting with the wind. When there is no wind use the engine to reverse slowly. Do not drop all your chain on top of the anchor
- For a short lunch break use a 3:1 scope (three times the depth of the water including the height of the hull). Increase to at least 7:1 scope when leaving the boat unattended or in heavy weather
- Attach the chain to the boat using a chain stopper or snubbing line. Don't let the windlass take the load when at anchor
- Reverse the boat slowly until the anchor holds.
- When at anchor, check your position from time to time



## Anchor windlass control panel

Milled from an aluminium plate anodised to ensure perfect protection against all (marine) weather conditions.

The microprocessor based panel features many advantages. Operate the winch by simply pushing the up or down button.

The panel has a visual and audible alarm indication.



81 x 85MM

FD.010.20000

- **Visual and audible alarms**
- **Automatic switch-off of the panel**  
User selectable:
  - switch-off after 30 (factory setting), 60 or 120 minutes
  - don't switch-off automatically
- Coated printed wiring board and rear cover to protect against humidity and salt air
- **"Child protection"** to ensure that the panels are not switched on by accident
- **Wire break detection.** Visual alarm if the electrical connection to the windlass relay is broken.
- Voltage supply 10.5-28V DC

## Anchor windlass control switch

In case of little space this switch could be a good alternative to control your windlass. The switch is supplied with gasket and a connection cable set with pre-wired connectors. All connectors have a latch lever lock, to ensure a 100% connection also in case of vibrations.

Maximum voltage: 24V DC

Maximum current: 15A

Frontside: IP66

Dimensions: 49 x 24 x 37.5mm



# EFFORTLESS ANCHORING

## Anchor chain 6mm 8mm 10mm

Craftsman Marine DIN766 calibrated chain assures trouble free operation of the windlass. Can also be used in other windlasses suitable for calibrated chain. Galvanised steel chain for reliable anchoring.

6mm

FG.010.20600

8mm

FG.010.20800

10mm

FG.010.21000



NEW

FG.020.20000

### Fixed bow roller

Polished stainless steel 316

Dimensions: 170x62x74mm (LxWxH)

For 6-10mm chain



NEW

FG.030.20000

### Chain stopper

Polished stainless steel 316

For 6-10mm chain

### TIPS FOR SAFE USE

The chainstopper is no substitute for a snubbing line. It is only there to keep your anchor in place in case the clutch of the windlass slips when sailing or to temporarily take the load off the windlass.

# CRAFTSMAN MARINE ACCESSORIES

*"Thoroughly tested with a perfect fit."*

Hoses for sanitation, water hoses, smart reducers to make sure all your hoses can be matched to your system, these are some of the items we call 'accessories'.

The Craftsman Marine accessories product line is constantly expanding with new and innovating products, all specially designed and manufactured for marine use. Flexible when needed, connecting engine

components, storage tanks, exhaust components and any other link between existing installations.

All our accessories are thoroughly tested and designed to meet the most stringent quality requirements for the marine environment. Our accessories are designed for easy installation and ensure a perfect fit.

LLOYD  
SAE J2





### Exhaust hose

Flexible exhaust hose for installations in tight compartments. Small bending radius of only 1.5x the diameter. For hoses larger than 152mm the bending radius is 2x the diameter. Operational temperature range -30°C to +100°C with a short peak load of 115°C.

Type approval: Lloyd's Register certificate No. 02/0029  
SAE J 2006 R1 and R2

Article code	Diameter (mm)	Weight (kg/m)	Bending radius (mm)
GA.010.20030	ø30 x 38	0,55	48
GA.010.20040	ø40 x 48	0,79	60
GA.010.20045	ø45 x 53	0,88	68
GA.010.20050	ø51 x 59	1,1	77
GA.010.20057	ø57 x 65	1,1	86
GA.010.20060	ø60 x 68	1,2	90
GA.010.20065	ø65 x 73	1,3	98
GA.010.20075	ø76 x 84	1,4	114
GA.010.20090	ø90 x 98	1,9	135
GA.010.20100	ø102 x 110	2,3	153
GA.010.20125	ø127 x 137	3,3	191
GA.010.20150	ø152 x 163	4,4	228
GA.010.20200	ø203 x 218	6,8	406



### Reinforced hydraulic hose

Flexible hose for hydraulic steering systems.

Article code	Diameter (mm)	Weight (kg/m)	Bending radius (mm)
BM.020.20020	ø8 x 14	0,2	46



### Fuel filling hose

Lloyd's approved high quality fuel filling hose with steel spiral. To provide a flexible connection between the fuel tank and the fill pipe. It is exceptionally flexible and can withstand temperatures of -30°C to +100°C.

Complies with SAE J 1527 and ISO 7840-MARINE FUEL A2

Article code	Diameter (mm)	Weight (kg/m)	Bending radius (mm)
GA.020.20038	ø38 x 50	1,1	76
GA.020.20051	ø51 x 63	1,5	102



### Fuel hose

To connect your fuel tank and filters to the engine. A1 quality to be used with diesel fuel and petrol. May also be used as breather line.

Complies with ISO 7840-MARINE FUEL A1

Article code	Diameter (mm)	Weight (kg/m)	Bending radius (mm)
GA.030.20008	ø8 x 16	0,24	30
GA.030.20010	ø10 x 18	0,28	35
GA.030.20013	ø13 x 22	0,39	50
GA.030.20015	ø15 x 25	0,45	60
GA.030.20019	ø20 x 28	0,52	80



**Sanitation hose SBR**

Non-permeable sanitation hose for waste water system. With SBR cover and incorporated steel spiral. Operational temperatures between -40° C and +70° C.

Article code	Diameter (mm)	Weight (kg/m)	Bending radius (mm)
GA.040.20016	ø16 x 26	0,45	50
GA.040.20019	ø19 x 29	0,55	65
GA.040.20025	ø25 x 36	0,72	75
GA.040.20038	ø38 x 48	1,15	100



**Water hose**

Smooth PVC water hose with steel spiral. Can be used between -5° C and +65° C.

Article code	Diameter (mm)	Weight (kg/m)	Bending radius (mm)
GA.050.20016	ø16 x 22	0,23	35
GA.050.20019	ø19 x 26	0,32	50
GA.050.20025	ø25 x 33	0,53	60
GA.050.20032	ø32 x 40	0,65	75
GA.050.20038	ø38 x 47	0,8	90
GA.050.20040	ø40 x 49	0,87	95



**Sanitation hose**

Water suction and discharge hose. Can be used for water and waste water. Made of PVC with internal spiral. Operational temperatures between -5° C and +65° C.

Article code	Diameter (mm)	Weight (kg/m)	Bending radius (mm)
GA.045.20020	ø20 x 27	0,32	50
GA.045.20025	ø25 x 33	0,53	65
GA.045.20038	ø38 x 47	0,8	90



**Reducers** RENEWED

Synthetic reducers to connect different sizes of hoses together. Suitable for hoses with an internal diameter from 16 to 38mm. Unlike many other reducers on offer the Craftsman Marine reducers can be used in hot water systems and the material is generally accepted for drinking water systems.

Article code	Diameter (mm)
GB.050.21619	Reducer 16-19mm
GB.050.21925	Reducer 19-25mm
GB.050.22532	Reducer 25-32mm
GB.050.22538	Reducer 25-38mm
GB.050.23238	Reducer 32-38mm



**Airvent nipple**

Produced from stainless steel 316 or chrome-plated brass (CPB) MS58. Suitable for 16mm or 19mm internal diameter hose. Straight or 90° angled.

	CPB	Stainless steel
<b>Straight 16mm</b>	CD.010.21016	CD.010.21116
<b>Straight 19mm</b>	CD.010.21019	-
<b>Angled 16mm</b>	CD.010.22016	CD.010.22116

**Airvent nipple flush**

Flush design. Produced from stainless steel 316 and available in straight or angled design. Suitable for 16mm and 19mm internal diameter hose.



<b>Straight 19mm</b>
CD.010.21119

<b>Angled 16mm</b>
CD.010.22316

**Deck fillers**

Stainless steel (AISI316) deck filler. With O-ring seal and key to prevent unauthorised opening. Hose connection ø38 mm. Flange diameter 73mm.



<b>DIESEL FUEL (38mm)</b>	<b>WATER (38mm)</b>	<b>WASTE (38mm)</b>
CC.010.20010	CC.010.20020	CC.010.20030



**Cross Bollard Single**

Finished to a high gloss and made from durable stainless steel 316, these bollards are made to last. Available as bolt-on base type or weld down fixing.

Height	Diameter	with baseplate	direct welding
90mm	ø38 mm	FH.010.20090	FH.010.25090
100mm	ø50 mm	FH.010.20100	FH.010.25100
115mm	ø60 mm	FH.010.20115	FH.010.25115
150mm	ø76 mm	FH.010.20150	FH.010.25150
160mm	ø89 mm	FH.010.20160	FH.010.25160
180mm	ø102 mm	FH.010.20180	FH.010.25180



**Deck cleat**

Stainless steel 316 deck cleats with blind mountings so no visible fasteners. High-gloss polished finish.

Length	Stainless steel
150mm	FH.020.20010
205mm	FH.020.20020
265mm	FH.020.20030
310mm	FH.020.20040

## Valves and fittings

Craftsman Marine only supplies high quality CR (corrosion resistant) brass that is suitable for continuous immersion in salt water. Regular brass should never be used below the waterline when sailing in salt water. This is because regular brass is an alloy of copper and zinc and is prone to a form of corrosion called dezincification. Zinc is leached from the metal and the remaining copper shell becomes porous and fragile.



### Thru-hull fitting

Produced from stainless steel 316 or CR Brass.

	CR Brass	Stainless steel
<b>G 3/4</b>	GB.030.20019	GB.035.20019
<b>G 1</b>	GB.030.20025	GB.035.20025
<b>G 1 1/4</b>	GB.030.20032	GB.035.20032
<b>G 1 1/2</b>	GB.030.20038	GB.035.20038
<b>G 2</b>	GB.030.20051	GB.035.20051



### Ball valves

Easy and quick to operate, with immediate visual indication. Produced from stainless steel 316 or CR brass.

	CR Brass	Stainless steel
<b>G 3/4</b>	GB.010.20019	GB.015.20019
<b>G 1</b>	GB.010.20025	GB.015.20025
<b>G 1 1/4</b>	GB.010.20032	GB.015.20032
<b>G 1 1/2</b>	GB.010.20038	GB.015.20038
<b>G 2</b>	GB.010.20051	GB.015.20051



### Hose pillar

Produced from stainless steel 316 or CR Brass.

	CR Brass	Stainless steel
<b>G 3/4-19mm</b>	GB.020.21919	GB.025.21919
<b>G 1-25mm</b>	GB.020.22525	GB.025.22525
<b>G 1 1/4-32mm</b>	GB.020.23232	GB.025.23232
<b>G 1 1/2-38mm</b>	GB.020.23838	GB.025.23838
<b>G 1 1/2-51mm</b>	GB.020.23851	GB.025.23851
<b>G 2-51mm</b>	GB.020.25151	GB.025.25151



### Water scoop

Produced from stainless steel 316 or CR Brass.

	CR Brass	Stainless steel
<b>G 3/4</b>	GB.040.20019	GB.045.20019
<b>G 1</b>	GB.040.20025	GB.045.20025
<b>G 1 1/4</b>	GB.040.20032	GB.045.20032
<b>G 1 1/2</b>	GB.040.20038	GB.045.20038
<b>G 2</b>	GB.040.20051	GB.045.20051



Craftsman Marine BV, All rights reserved.  
Reproduction in whole or in part without permission  
is prohibited.

Craftsman Marine BV reserves the right to change  
product designs or specifications without prior notice  
and cannot be held liable for typographical errors,  
layout error or misinformation contained herein.



This catalogue by Craftsman Marine has been created with the help of the following people:

**Content**

Soerín Soekhoe, Garnik Avagyan,  
Jorg Bieringa, Joost Zwiers,  
René van der Schaft, René Klaris

**DTP/Layout**

Fion Kaskandar

**Photography**

Withney Irokromo

