



Marine propulsion and mechanical drive





Our expertise,
the marine propulsion





One century of experience in Moteurs Baudouin complete propulsion system design and manufacturing has been built on the basis of our customer care vision: the knowledge and understanding of your business to offer the adapted solution to your durable investment requirements and operational costs savings.

Moteurs Baudouin proposes today its marine propulsion diesel engine range from 60 to 883 kW dedicated to the most performing and severe applications. Being gearboxes and FPP-CPP propellers designer, we analyze your specifications to provide our in house and optimized integration solution. We also permanently keep in mind your business specificities to release reliability and efficiency proven products also respectful towards our environment.

We are committed today and more than ever to provide advices for your projects and products support necessary to a durable trust relationship as already granted by thousands of marine professional worldwide users.

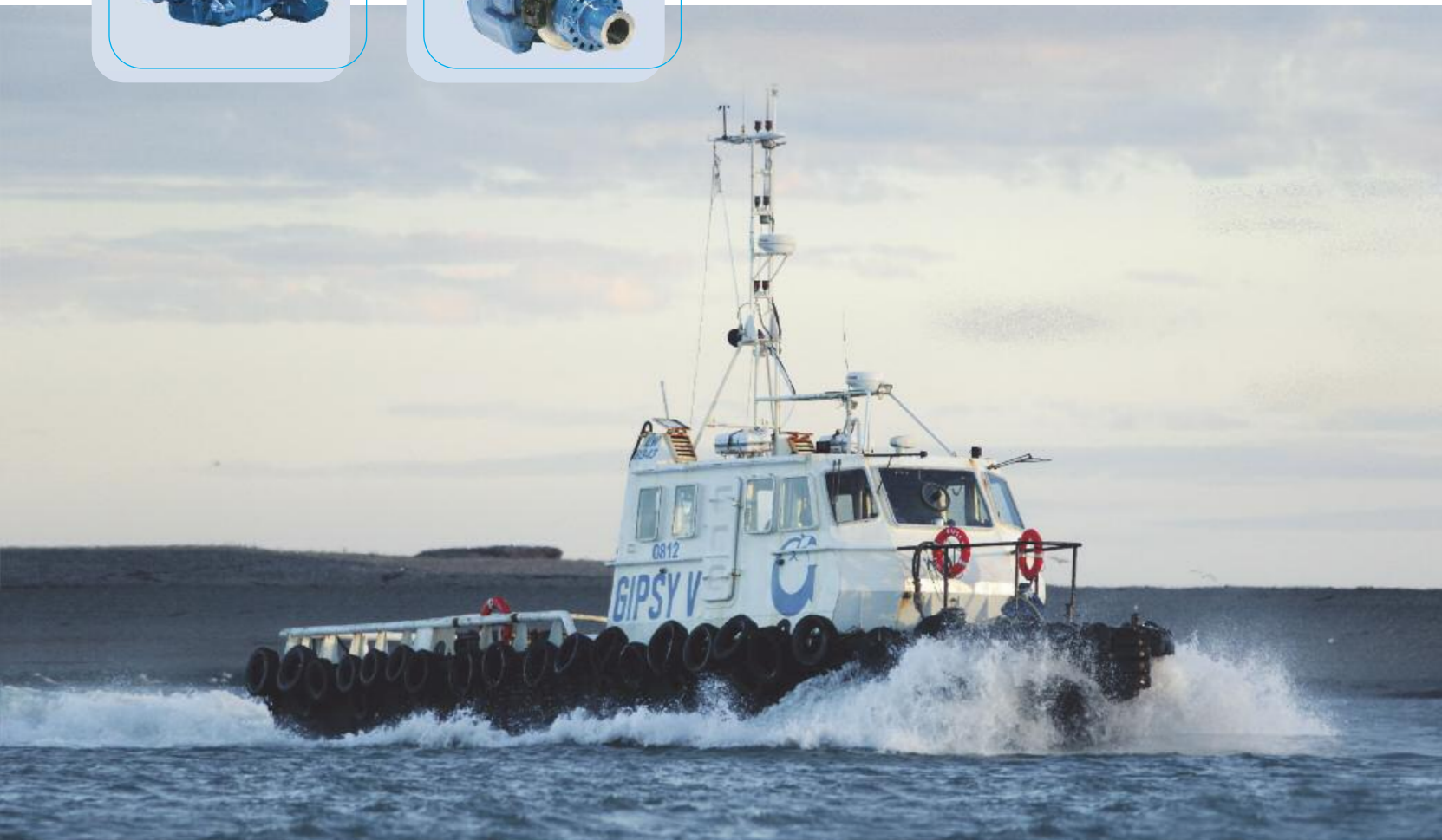

Definitions & Standards

Certifications

IMO Tier 2 MARPOL 73/78 - CCNR Tier 2 - CE 97/68 Phase IIIA certified

Our engines are complying with the main certification societies (ABS, BV, CCS, DNV, GL, LRS, RINA, RMRS...)

Power definition

Standard ISO 3046/1 - 1995 (F)

Reference conditions

Ambient	25 °C / 77 °F
Barometric pressure	100 kPa
Relative humidity	30 %
Sea water temperature	25 °C / 77 °F

Fuel oil

Relative density	0.840 ± 0.005
Lower calorific power	42 700 kJ/kg
Consumption tolerances	0 ± 5 %
Air inlet limit temperature	35 °C / 95 °F

Our rating also comply with classification societies maximum temperature definition without power derating:

- Ambient temperature: **45 °C / 113 °F**
- Sea water temperature: **32 °C / 90 °F**

Marine propulsion and mechanical drive

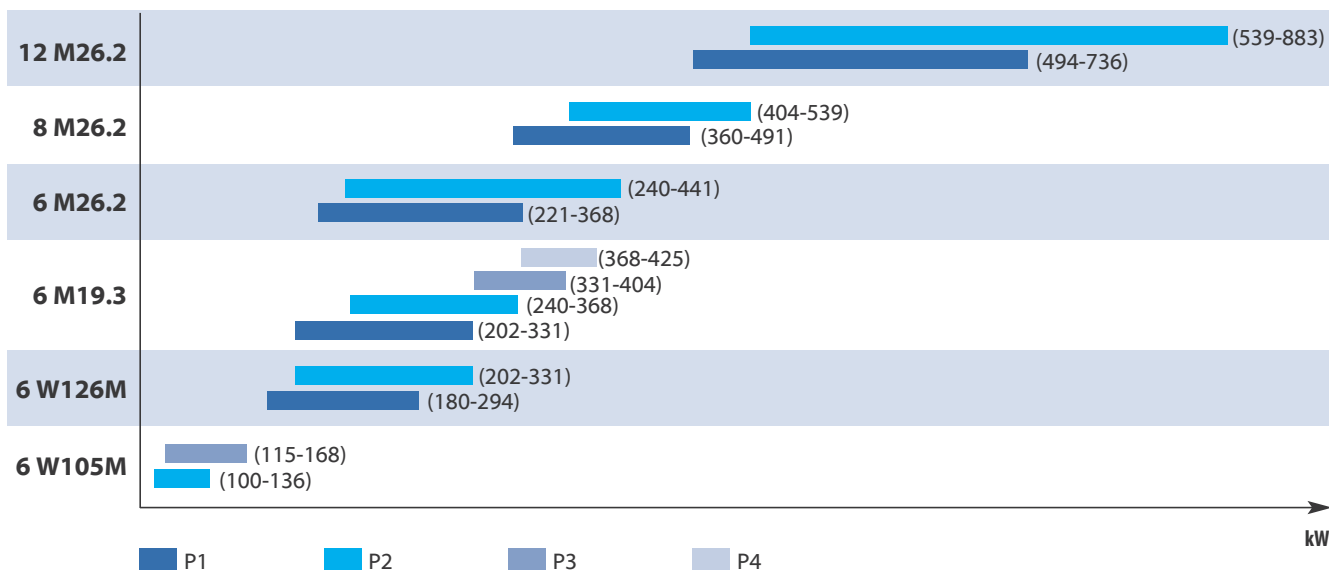

Class of duty

Marine propulsion

	P1 duty	P2 duty	P3 duty	P4 duty
Application	unrestricted continuous	continuous	intermittent	high performance
Engine load variations	very little or none	numerous	important	very important
Mean engine load factor	80 to 100 %	30 to 80 %	50 %	30 %
Annual working time	more than 5 000 h	3 000 to 5 000 h	1 000 to 3 000 h	less than 1 000 h
Time at full load	unlimited	8 h each 12 h	2 h each 12 h	1 h each 12 h



6 W126M



The W series, towards a new durable investment concept

The W engines range development is the conclusion of a simple idea, to reconcile operational and environmental stakes in your business with your economical constraints at investment stage and throughout the whole product life cycle.

The W series are at first our latest evolution of large scale products experience in all marine applications worldwide. Based on such customer product quality recognition, we have developed an innovating solution against the increased technology complexity trend. With the W105 and W126 engines, 60 to 331 KW, 1500 to 2425 rpm, your business is our concern.

Your benefits

- The reasonable investment choice
- The in house propulsion package with one single partner
- A controlled technology for a simple and economical maintenance you will experience as unique
- An optimized fuel consumption with an affordable mechanical injection
- Reliability and availability even in extreme working conditions

6 W105M



- 4 strokes marine diesel engines, direct injection, turbocharged, with charge air intercooling

	6 W105M	6 W126M
Number of cylinders	6 in line	
Bore and stroke	105 x 130 mm	126 x 155 mm
Total displacement	6.75 l	11.56 l
Engine rotation	CCW* (ISO 1204 standard)	
Idling speed	650 rpm	600 rpm
Flywheel housing	SAE 3	SAE 1
Flywheel	SAE 11.5"	SAE 14"

* CCW: counter-clockwise

Rated power for marine propulsion and mechanical drive

	Rating		Speed	Fuel consumption	Duty
	hp	kW	rpm	g/kWh	
6 W105M	185	136	2100	211	P2
	228	168	2425	216	P3
6 W126M	400	294	1800	200	P1
	450	331	2100	210	P2

Contact us for inland river application engines power.

6 W105M

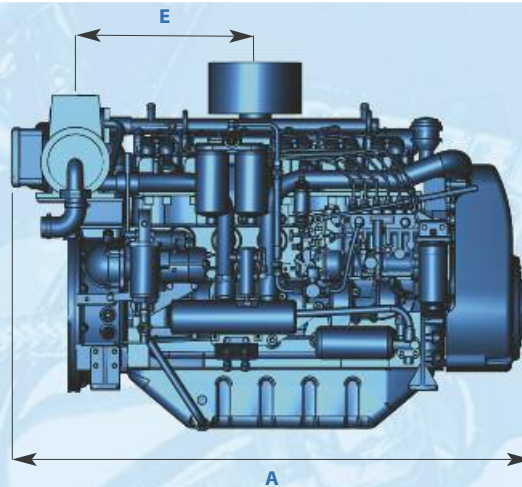
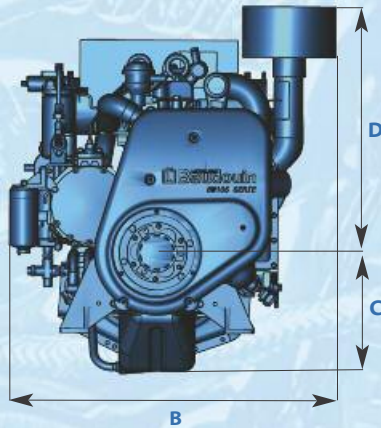

6 W126M

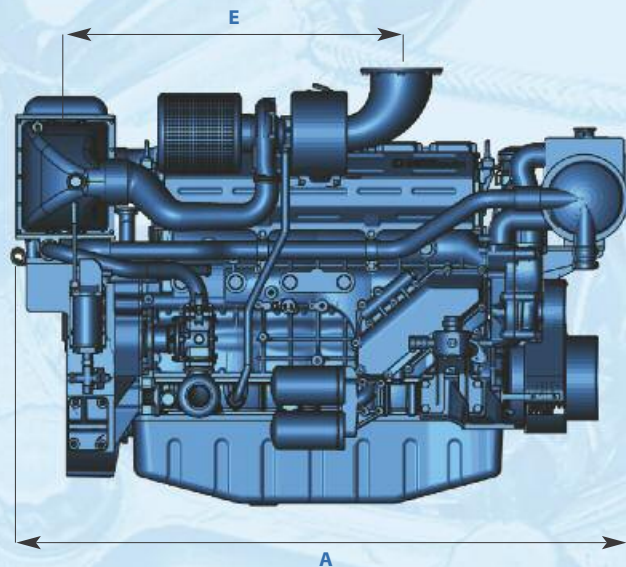
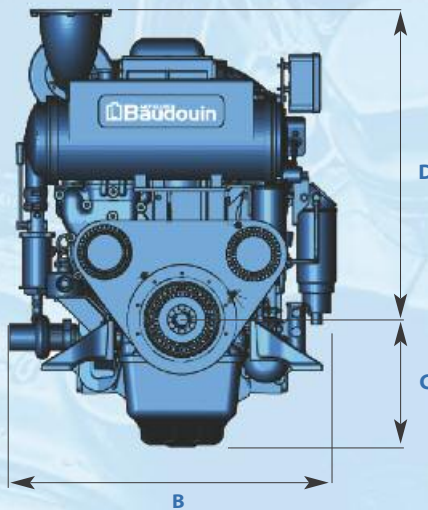

Standard equipments

Engine and block

- Cast iron cylinder block, with replaceable cylinder liners
- Separate cast iron cylinder heads
- Replaceable valves guides and seats
- Steel forged crankshaft with 7 bearings
- Lube oil cooled light alloy piston with 3 high performance piston rings

Cooling system

- Fresh / raw water heat exchanger with integrated thermostatic valves and expansion tank
- Cast iron centrifugal fresh water pump, mechanically driven
- Bronze self-priming raw water pump, mechanically driven

Lubrication system

- Full flow screwable oil filters
- Fresh water cooled lube oil cooler

Optional equipments (extract)*

- Cooling system adapted for box / keel cooling
- Connection for emergency raw water circuit
- Bilge pump

- Air starter
- Free end PTO

Fuel system

- In line injection pump with flanged mechanical governor
- Double wall injection bundle
- Duplex fuel filters replaceable engine running
- Water separator

Intake air and exhaust system

- Insulated exhaust gas manifold
- Turbo blower with insulated turbine housing
- Low water temperature cooled intake air cooler

Electrical system

- Voltage: 24Vcc
- Electrical starter on flywheel crown
- 35A battery charger

- Resilient mounts under engine
- Exhaust water injection after turbocharger

* contact us for further information regarding our options.

Main dimensions and weight

	A	B	C	D	E	Weight (kg)
6 W105M	1417	908	330	689	103	810
6 W126M	1695	883	351	1006	926	1200

Connections

	Seawater inlet (mm)	Seawater outlet (mm)	Exhaust (mm)
6 W105M	Ø inn 45	Ø inn 45	Ø inn 83 / Ø out 142
6 W126M	Ø inn 63,5	Ø inn 38	Ø inn 180 / Ø out 225

FUEL FOR ALL ENGINES

Ø fuel inlet (mm): 12 Ø fuel outlet (mm): 12 Ø fuel leak (mm): 8

Performances

6 W105M

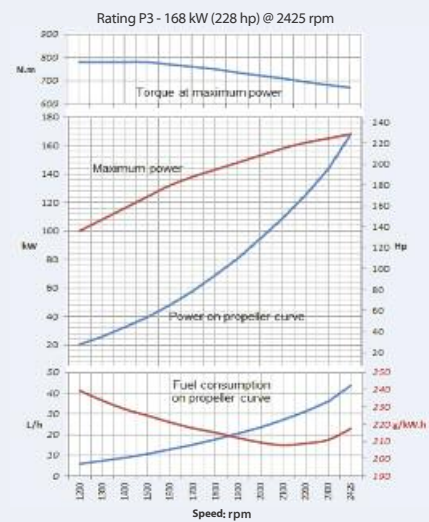
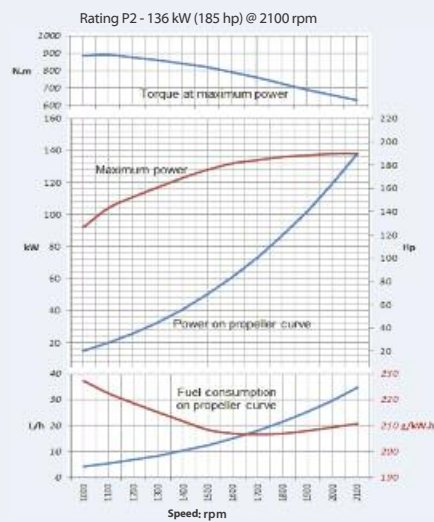

6 W126M

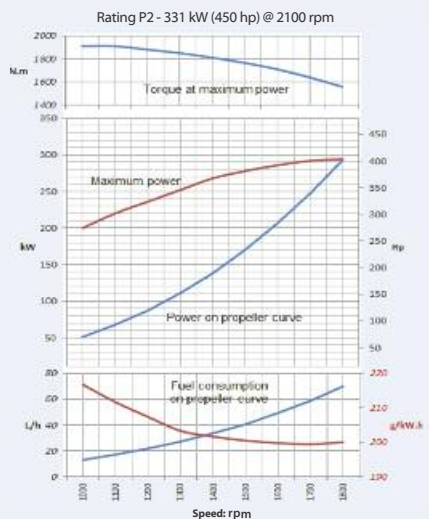
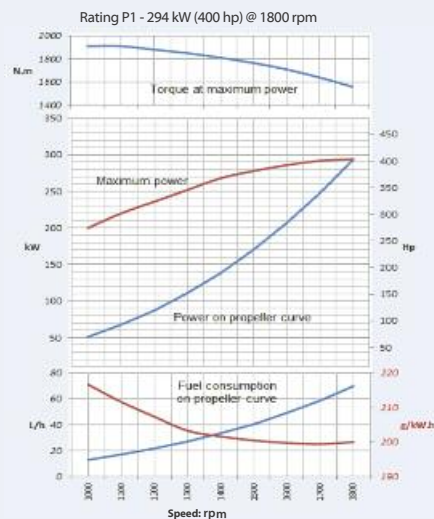



6 M19.3



6 M19.3: The power simply making the difference

The Moteurs Baudouin 6 M19.3 first common rail engine introduction in our marine range both prepares the future and provides today's ultimate durable customer investment. Thus fuel oil savings, performance and reliable power are among the 6 M19.3 key outstanding features.

From continuous to intermittent power the **6 M19.3** is from now ready to comply with the future exhaust gas emissions regulation IMO Marpol Tier 2 - CCNR Tier 2 and CE97/68 stage 3A. But beyond the sole regulations concern, Moteurs Baudouin has a global environment care approach and the 6 M19.3 provides among the **best fuel oil consumption** in its category. Thanks to our Research & Development center the 6 M19.3 becomes a truly economical and durable marine power reference.

Your benefits

- The fuel oil savings reference
- A wide high torque area for optimal towing performance
- A new Moteurs Baudouin in house marine solution
- A users friendly integrated injection diagnostic
- Low maintenance cost in Moteurs Baudouin marine tradition

6 M19.3

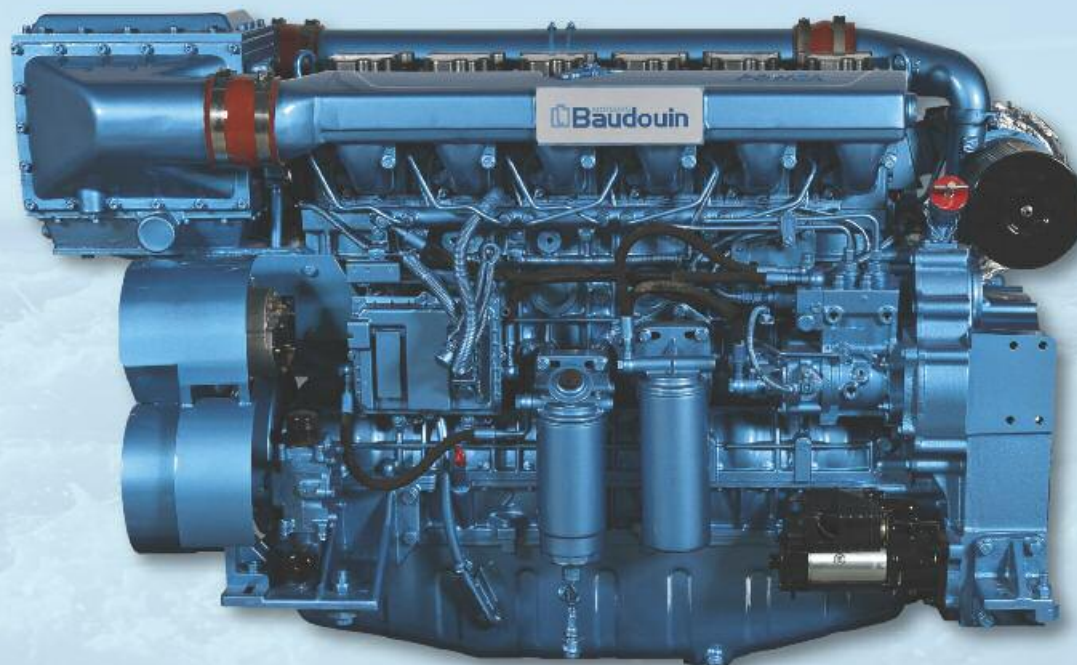

- 4 strokes marine diesel engine, direct injection, common-rail

	6 M19.3
Number of cylinders	6 in line
Bore and stroke	126 x 155 mm
Total displacement	11.56 l
Engine rotation	CCW*(ISO 1204 standard)
Idling speed	600 rpm
Flywheel housing	SAE 1
Flywheel	SAE 14"

*CCW: counter-clockwise

Rated power for marine propulsion and mechanical drive

	Rating		Speed	Fuel consumption	Duty
	hp	kW	rpm	g/kWh	
6 M19.3	450	331	1800	199	P1
	500	368	2100	205	P2
	550	404	2100	209	P3
	578	425	2200	218	P4

Contact us for inland river application engines power.

6 M19.3

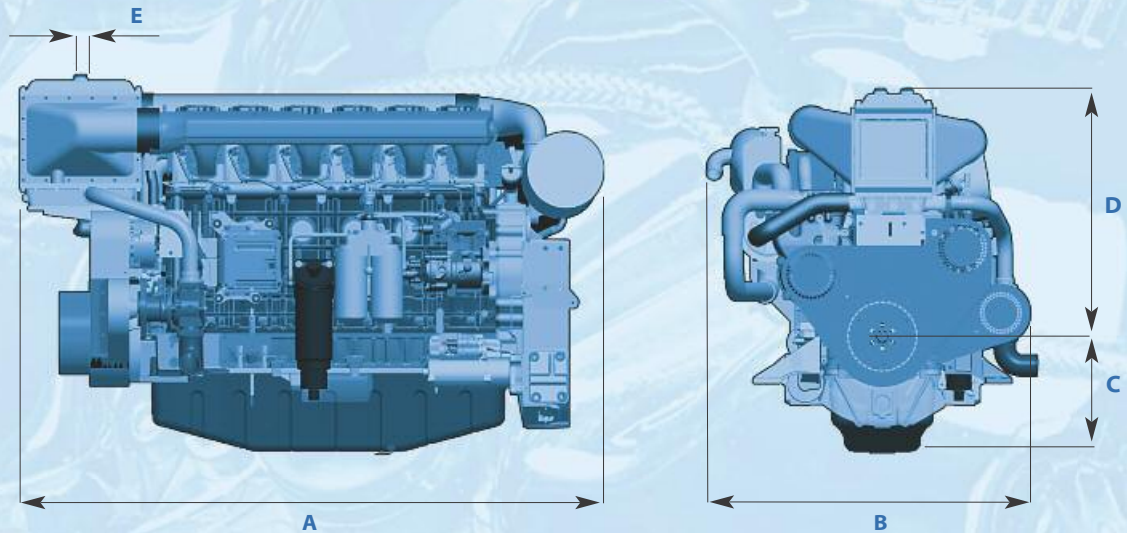

Standard equipments

Engine and block

- Cast iron cylinder block, with replaceable cylinder liners
- Separate cast iron cylinder heads equipped with 4 valves
- Replaceable valves guides and seats
- Steel forged crankshaft with 7 bearings
- Lube oil cooled light alloy piston with 3 high performance piston rings

Cooling system

- Fresh / raw water heat exchanger with integrated thermostatic valves and expansion tank
- Cast iron centrifugal fresh water pump, mechanically driven
- Bronze self-priming raw water pump, mechanically driven

Lubrication system

- Full flow duplex type oil filters
- Fresh water cooled lube oil cooler plate type

Optional equipments (extract)*

- Cooling system adapted for box / keel cooling
- Connection for emergency raw water circuit
- Bilge pump
- Air starter
- Promachined free end PTO

Fuel system

- Electronic common-rail injection
- Double wall injection bundle with alarm and leakage collector
- Duplex fuel filters replaceable engine running
- Water separator

Intake air and exhaust system

- Exhaust gas manifold cooled by the engine fresh water
- Dry turbo blower insulated
- Low water temperature cooled intake air cooler

Electrical system

- Voltage: 24Vcc
- Electrical starter on flywheel crown
- 35A battery charger
- Wheelhouse control panel

- Resilient mounts under engine
- Exhaust water injection after turbocharger
- Fresh water electrically heated
- Cabin heating

* contact us for further information regarding our options.

Main dimensions and weight

	A	B	C	D	E	Weight (kg)
6 M19.3	1664	949	349	741	7.6	1200

Connections

	Seawater inlet (mm)	Seawater outlet (mm)	Exhaust (mm)
6 M19.3	Ø inn 52	Ø inn 45	Ø inn 150 / Ø out 225

FUEL FOR ALL ENGINES

Ø fuel inlet (mm): 12 Ø fuel outlet (mm): 12 Ø fuel leak (mm): 8

Performances

6 M19.3

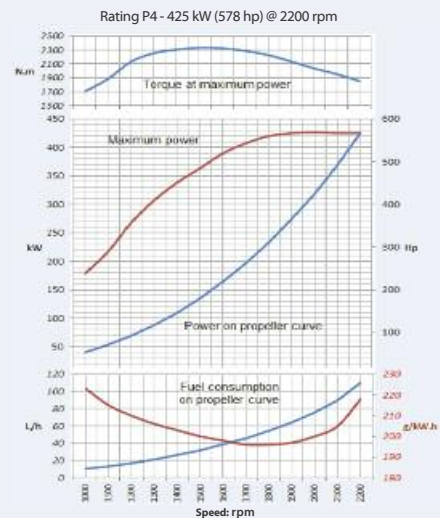
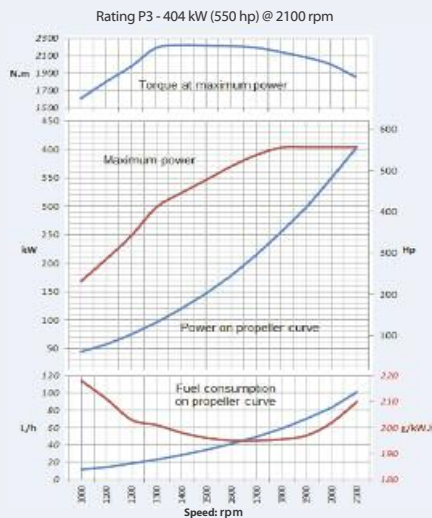
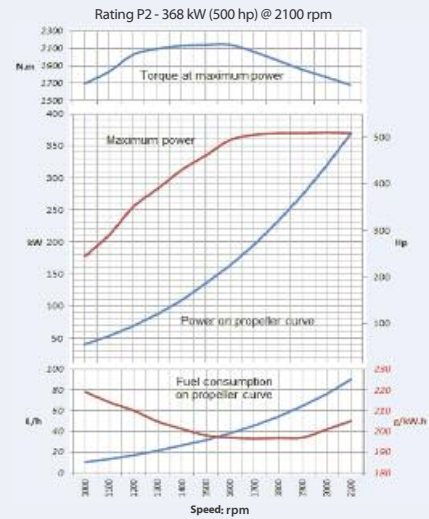
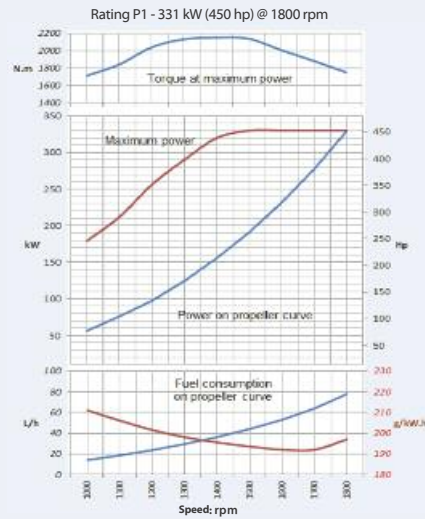



6 M26.2

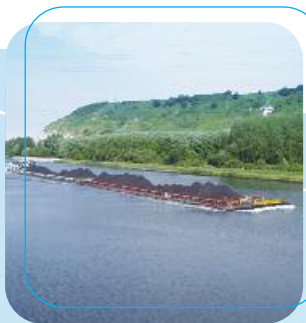

8 M26.2



The M26.2 product family, Green Power

The new series M26.2 IMO Tier II certified replaces the historical M26 contributing generation to Moteurs Baudouin reputation in the marine sector. In line with our constant customer care approach, our economical and proved solutions commitment are engraved as the basis of our R&D programs.

Thanks to our latest works in regard to environment protection and engine performance, **the M26.2** range combines both up to date marine and inland shipping regulations compliance advantages with its traditional and worldwide serviceable construction.

More advantages

- The flexible package solution customized to your project specification
- Engines born and designed for the marine propulsion
- Increased power with reduced fuel specific consumption
- The mechanical injection reliability and accessibility
- A product family with engine components interchangeability
- Extended M.T.B.O. with operational cost reduction certainty

- 4 strokes marine diesel engines, direct injection, turbocharged, with charge air intercooling

	6 M26.2	8 M26.2	12 M26.2
Number of cylinders	6 in line, 8 and 12 in Vee		
Bore and stroke	150 x 150 mm		
Total displacement	15.9l	21.2l	31.8l
Engine rotation	CCW* (ISO 1204 standard)		
Idling speed	700 rpm		
Flywheel housing	SAE 1	SAE 0	
Flywheel	SAE 14"		SAE 18"

* CCW: counter-clockwise

12 M26.2



Rated power for marine propulsion and for mechanical drive

	Rating		Speed	Fuel consumption	Duty
	hp	kW	rpm	g/kWh	
6 M26.2	450	331	1800	198	P1
	500	368	1800	205	P1
	550	404	1900	209	P2
	600	442	1950	211	P2
8 M26.2	600	442	1800	213	P1
	668	491	1800	212	P1
	733	539	1900	219	P2
12 M26.2	900	662	1800	198	P1
	1000	736	1800	197	P1
	1100	808	1900	200	P2
	1200	883	1950	201	P2

Informations regarding engines power for inland river application would be supply upon request.

Standard equipments

Engine and block

- Cast iron cylinder block
- One inspection door per cylinder for access to conrod cap
- Cast iron cylinder liners, wet type
- Separate cast iron cylinder heads equipped with 4 valves
- Replaceable valves guides and seats
- 8 cylinders head tightening bolts
- Hardened steel forged crankshaft with induction hardened journals, crankpins and radius
- Camshaft with polynomial cams profile
- Distribution with tempered, hardened and grinded helicoidal gears
- Chromium-Molibdenum steel conrods
- Lube oil cooled light alloy pistons with high performance piston rings

Cooling system

- Fresh / raw water heat exchanger with integrated thermostatic valves and expansion tank
- Cast iron centrifugal fresh water pump, mechanically driven

Optional equipments (extract)*

- Cooling system adapted for box / keel cooling
- Connection for emergency raw water and lube oil circuits
- Bilge pump
- Air starter with storage bottles and compressor

* contact us for further information regarding our options.

- Bronze self-priming raw water pump, mechanically driven

Lubrication system

- Full flow screwable oil filters
- Lube oil purifier with replaceable cartridge
- Fresh water cooled lube oil cooler

Fuel system

- In line injection pump with flanged mechanical governor
- Double wall injection bundle with leakage collector
- Duplex fuel filters replaceable engine running

Intake air and exhaust system

- Fresh water cooled turbo blower
- Double flow raw water cooled intake air cooler

Electrical system

- Voltage: 24Vcc
- Electrical starter on flywheel crown
- 175A battery charger

- Free end PTO
- Resilient mounts under engine
- Equipment and factory trial according to Major Classification Societies rules

6 M26.2

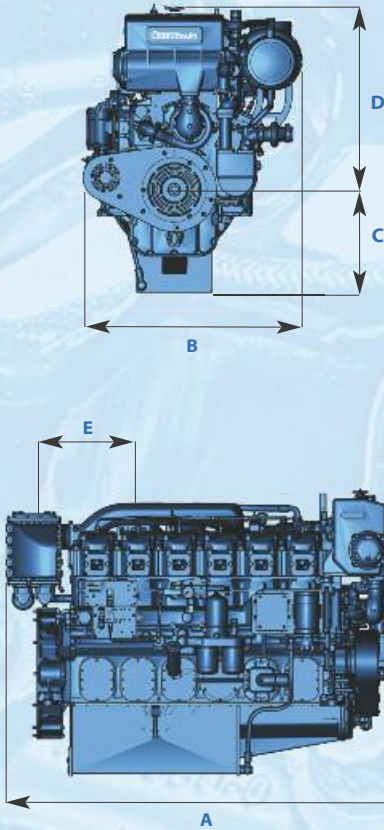

8 M26.2

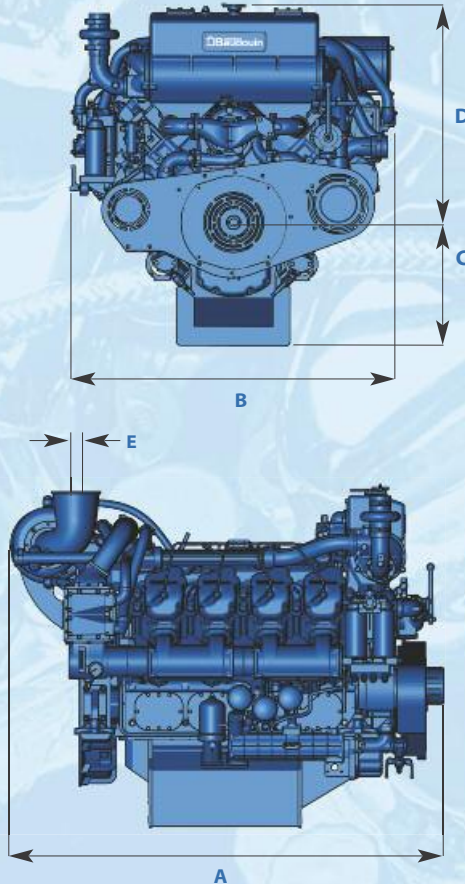

12 M26.2

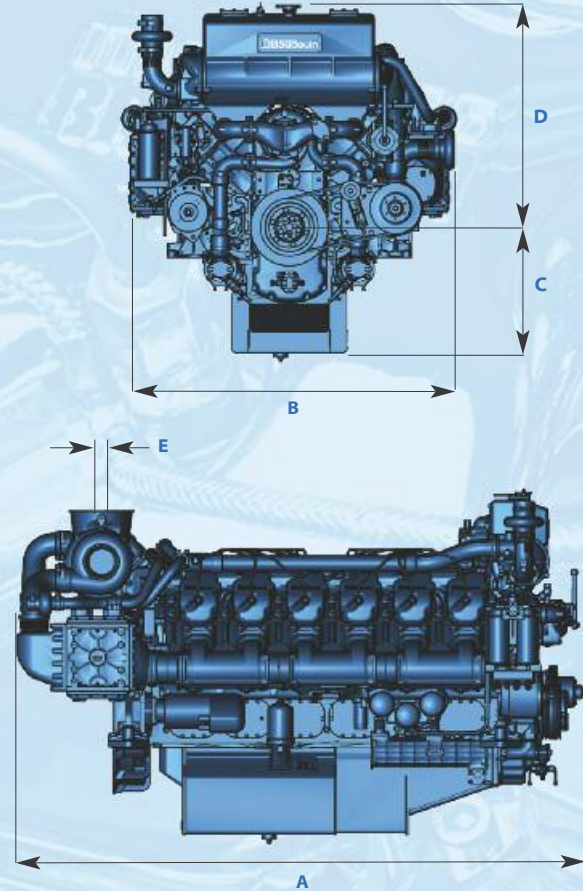

Main dimensions and weight

	A	B	C	D	E	Weight (kg)
6 M26.2	1880	1090	497	868	476	1785
8 M26.2	1884	1468	533	931	17	2475
12 M26.2	2446	1521	534	927	49.5	3400

Connections

	Seawater inlet (mm)	Seawater outlet (mm)	Exhaust (mm)
6 M26.2	Ø inn 63.5	Ø inn 50	Ø inn 194 / Ø out 205
8 M26.2	Ø inn 76.1	Ø inn 76.1	Ø inn 260 / Ø out 278
12 M26.2	Ø inn 76.1	Ø inn 76.1	Ø inn 260 / Ø out 278

FUEL FOR ALL ENGINES

Ø fuel inlet (mm): 12 Ø fuel outlet (mm): 12 Ø fuel leak (mm): 8

Performances 6 M26.2

Rating P1 - 331 kW (450 hp) @ 1800 rpm

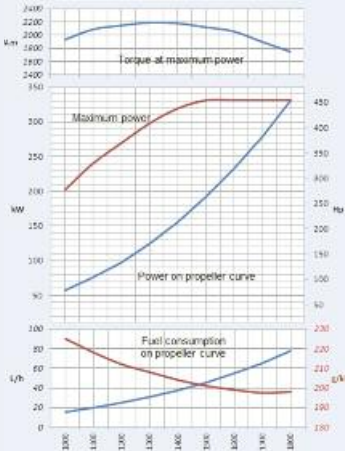

Rating P1 - 368 kW (500 hp) @ 1800 rpm

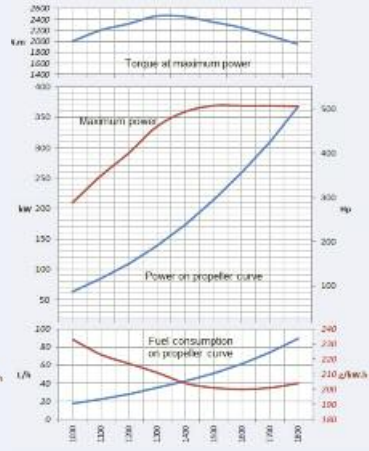

Rating P2 - 404 kW (550 hp) @ 1900 rpm

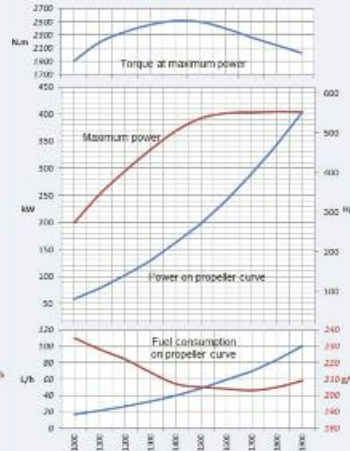

Rating P2 - 442 kW (600 hp) @ 1950 rpm

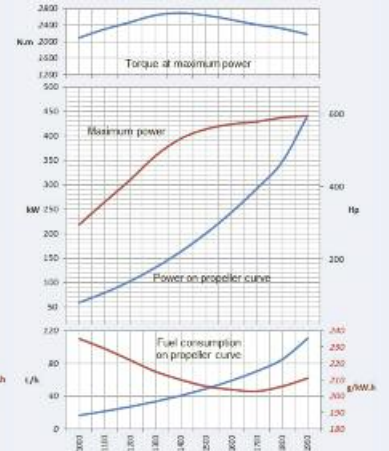

8 M26.2

Rating P1 - 442 kW (600 hp) @ 1800 rpm

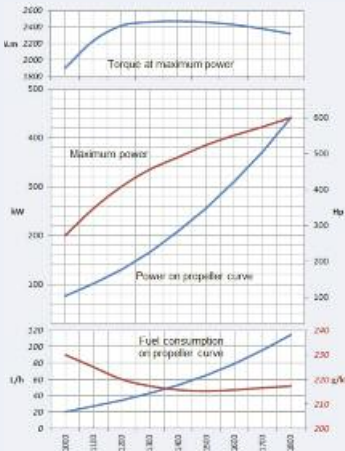

Rating P1 - 491 kW (668 hp) @ 1800 rpm

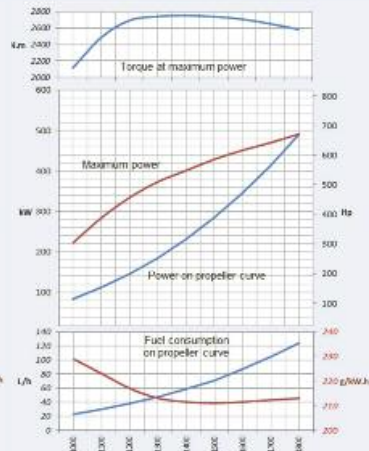

Rating P2 - 539 kW (733 hp) @ 1900 rpm

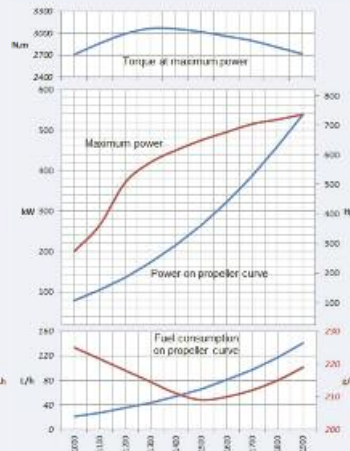

12 M26.2

Rating P1 - 662 kW (900 hp) @ 1800 rpm

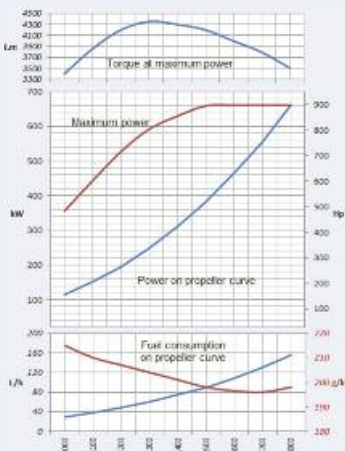

Rating P1 - 736 kW (1000 hp) @ 1800 rpm

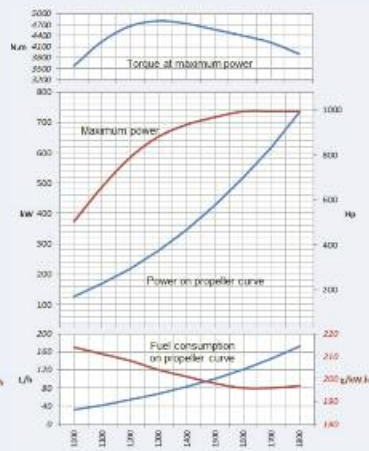

Rating P2 - 808 kW (1100 hp) @ 1900 rpm

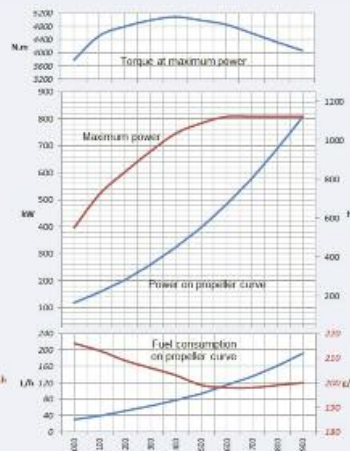

Rating P2 - 883 kW (1200 hp) @ 1950 rpm

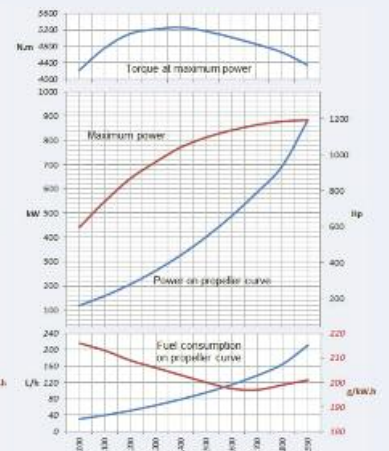

Speed : rpm

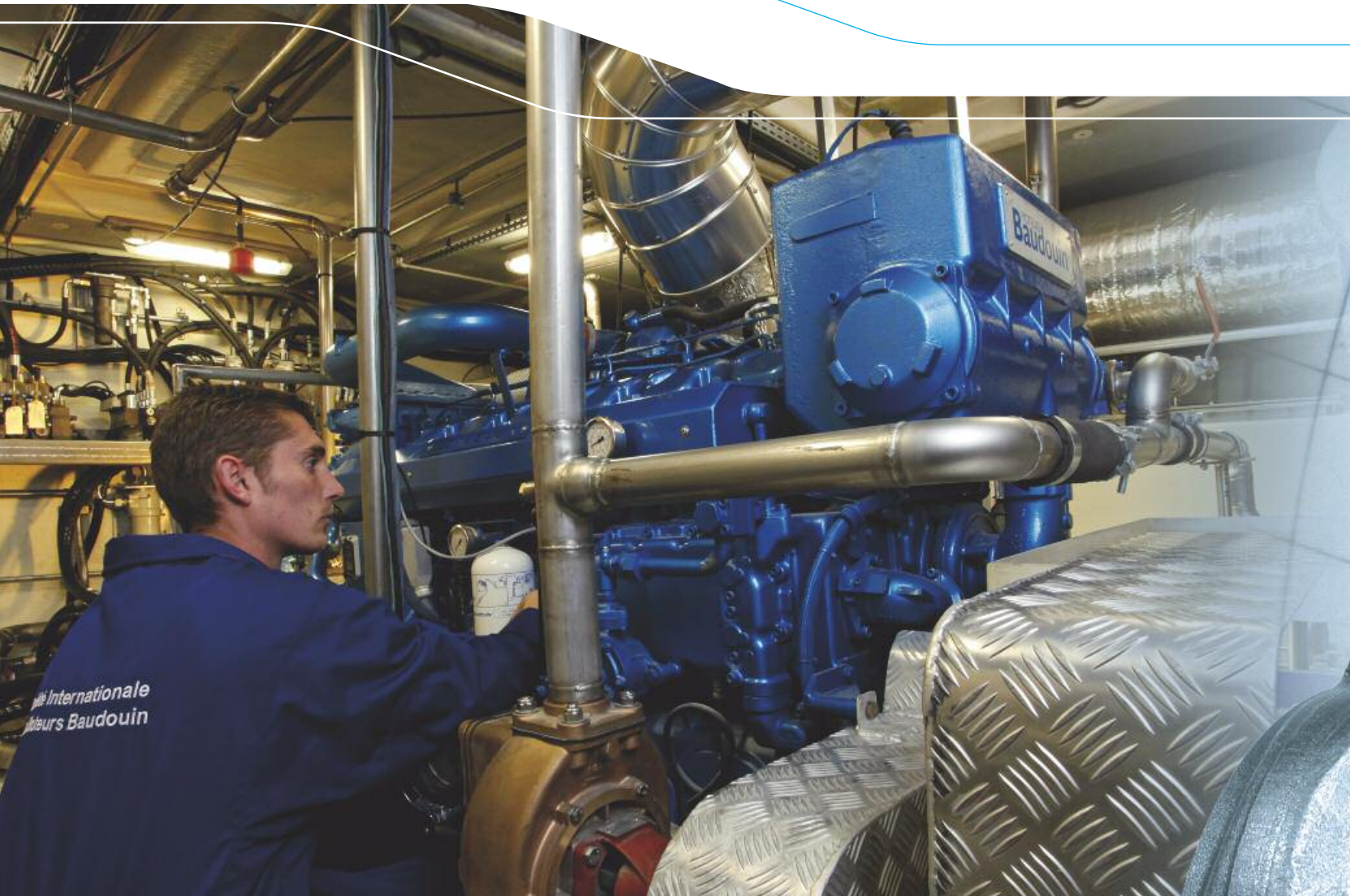

Moteurs Baudouin Service values

Wherever you are sailing in the world, Moteurs Baudouin is at your side. Our international marine experts is supporting your **over the 5 continents (95 countries)**. Their mission, to guaranty your equipment optimized performances through its life cycle. More than simple service, Moteurs Baudouin provides a wide range of customized support solutions that fits to your personal needs.

Our standard

- Commissioning and technical support
- Standard warranty on equipments and accessories
- Spare parts availability at your door
- Documentation and information bulletin
- From standard to general overhaul
- Engines components reconditioning

Our tailor made options

- Factory performance tests
- Diagnostic and preventive recommendations report
- Medium to long term service agreement
- Multi level training program
- Engines reconditioning

Please contact our Moteurs Baudouin local service network for further information about our service values.

MARINE DIESEL ENGINES

W & M RANGE



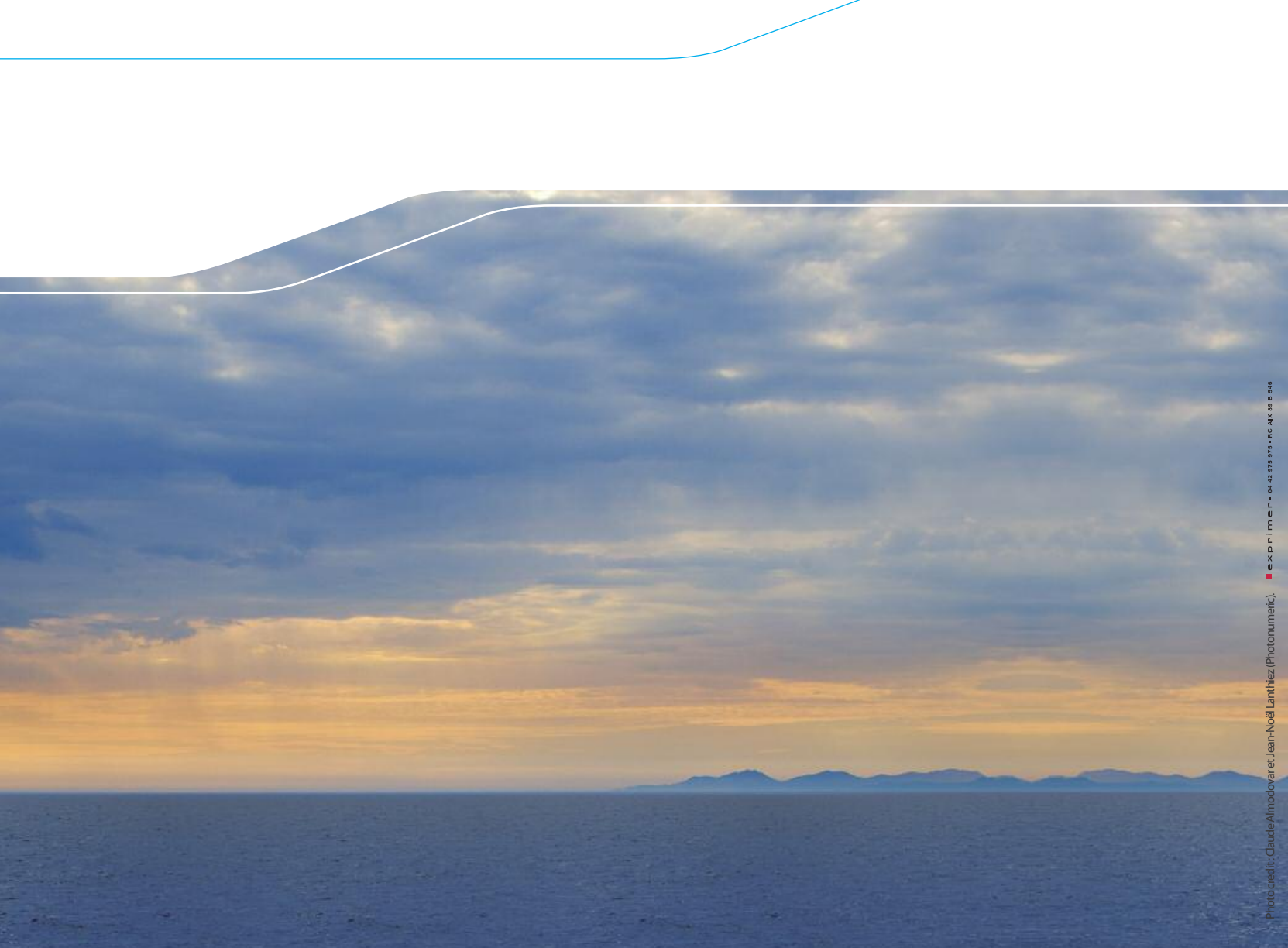

Société Internationale des Moteurs Baudouin

Technoparc du Brégadan - 13260 Cassis - France
tel. + 33 488 688 500 - fax + 33 488 688 501

www.moteurs-baudouin.com

Moteurs Baudouin® is a registered trademark.

